

Testbed for Wireless Mesh Backhaul Networks

MEMBRANE Demonstrator

Ilias Panayiotopoulos, Konstantinos Stamatis,
Konstantinos Avgeropoulos and Antonis Valkanas
Wireless Systems and Technologies Dept.
INTRACOM S.A. Telecom Solutions
Athens, Greece
{ipan|kost|kav|g|abal}@intracom.gr

Alexander Maltsev, Roman Maslennikov, Alexey
Khoryaev and Artyom Lomayev
Nizhny Novgorod Radio Lab
Intel Corp.
Nizhny Novgorod, Russia
alexander.maltsev@intel.com

Abstract— Wireless Backhaul Mesh Networks have attracted attention during the past few years due to their ease of deployment, flexibility and adaptiveness, compared to non-mesh networks. Besides studying and evaluating novel techniques and algorithms for such systems, IST project MEMBRANE aims to develop demonstrators to act as proof of concept and provide an implementation oriented perspective.

Two demonstrators are being implemented within the project, addressing different aspects of the proposed system. The first demonstrator focuses on link level cooperative communication for wireless mesh networks and the second focuses on optimized distributed scheduling and routing. This paper briefly describes the techniques and algorithms used in each case and provides the basic design principles of each of the demonstrators.

Keywords—Testbed, demonstrator, WiMAX, MEMBRANE

I. INTRODUCTION

The ubiquitous provision of wireless broadband services to remote users while achieving high performances and transmission rates under the severe propagation conditions is one of the challenges of the telecommunication community. The exploitation of wireless meshed techniques for backhaul networks constitute an attractive economical alternative to wired lines and high speed fibers. Typical wireless broadband solutions based on current standards and technologies such as WiMAX can not be used without modifications to cover the highly demanding requirements of a wireless backhaul network. Advanced multiple-antenna, scheduling, routing and cross-layer techniques must be designed and evaluated.

The research project MEMBRANE (Multi-Element Multihop Backhaul Reconfigurable Antenna Network) investigates such techniques and aims to design an efficient multi-antenna multihop wireless backhaul network capable to support the high speed QoS demands in terms of throughput and delay performances, coverage and overall capacity. In order to evaluate several novel techniques and technology enablers, a system simulation software platform providing link and system level performance results is developed. However, in order to provide a realistic proof-of-concept of several proposed multi-element scheduling and routing algorithms, a hardware prototype is built. The MEMBRANE demonstrator

will justify the economical viability of selected wireless mesh techniques with their implementation in a commercial hardware platform. The demonstrator will give an overview of methods and results related to technical hardware constraints. Pre-existing high performance platforms composed of SISO modules for an IEEE 802.16-2004 OFDM based physical layer [1] used as a starting point, and modified accordingly for the implementation of selected wireless mesh algorithms.

The MEMBRANE testbed aims to demonstrate two different features characterizing wireless meshed backhaul networks. On one side, the ability of the backhaul network to support high transmission rates imposes the deployment of multiple antenna techniques that must mitigate interference from concurrent multi-hop transmissions and provide high multiplexing and/or diversity gain. On the other hand, the backhaul network must be capable to respond to extremely variable and sudden traffic loads while the Quality-of-Service (QoS) demands in terms of throughput, end-to-end delay and outage is maintained constant. Hence, the MEMBRANE testbed is composed of two demonstrators. The first one aims to demonstrate the advantages of reconfigurable MIMO algorithms which mainly concerns optimization of the multiple-antenna link signalling and routing involving the PHY and MAC layers. The second demonstrator aims to show the achievable gain of protocols that jointly optimize routing and scheduling through cross-layer design from the PHY to the Network layer.

In this paper, after a general description of the algorithms and protocols selected for demonstration, the two prototypes of the MEMBRANE project are presented. These two demonstrators are composed of different hardware components and their target is to demonstrate the two different aspects of the MEMBRANE system presented above. In one sense, they provide an adequate proof that the MEMBRANE concept can be simply implemented in commercial hardware platforms.

II. COOPERATIVE MULTIPLE ANTENNA TECHNIQUES DEMONSTRATOR

Cooperative multiple antenna techniques are among key technology enablers of the high-performance QoS-oriented

wireless mesh backhaul networks and thus such techniques were intensively investigated during the MEMBRANE project. An outcome of this work was the development of several multiple antenna algorithms optimized for multihop transmission in the backhaul scenarios [2]. The goal of the MEMBRANE cooperative multiple antenna techniques demonstrator is to show the performance advantages of the proposed algorithms in the real-time with the real network traffic.

The Data Splitting Algorithm (DSA) [3] was selected for implementation in the cooperative multiple antenna demonstrator. The DSA algorithm proposes a novel concept for high throughput transmissions with multiple antennas from the source node to the destination node through several relay nodes. Differently from well known schemes where data stream is sent to destination through one relay, in the DSA algorithms several independent streams are routed to different relays and at the same time sent directly to the destination in order to maximize the system throughput. This approach is particularly appealing for propagation scenarios with the spatially correlated MIMO channels between single node pair, when the spatial multiplexing gain cannot be fully obtained by sending the data via only one relay node. In this case the

cooperative multiple antenna transmission through several nodes will be beneficial.

The configuration setup includes 4 nodes in total: one base station, two relay stations and one subscriber station, were chosen. The emulation of two antennas on each prototype node was implemented. This configuration is able to demonstrate different modes of data transmission with two simultaneous spatial streams. These two data streams may be a 2x2 MIMO transmission between two nodes or different combinations of two parallel SISO transmissions. All possible transmission modes that were implemented in the demonstrator are shown in Fig. 1. The DSA algorithm adaptively chooses the best transmission mode based on the capacity maximization criterion. In all cases, the DSA algorithm guarantees effective cancellation of the interference between the active spatial streams.

Each node of the demonstrator was implemented using the off-the-shelf FPGA prototyping platform *DSP Development Kit, Stratix II Edition* from Altera [4]. The communication protocol between nodes was realized in accordance with IEEE 802.16-2004 OFDM specification but many aspects of the protocol were simplified to avoid technical issues not related to the demonstrator goals. The bandwidth of the single

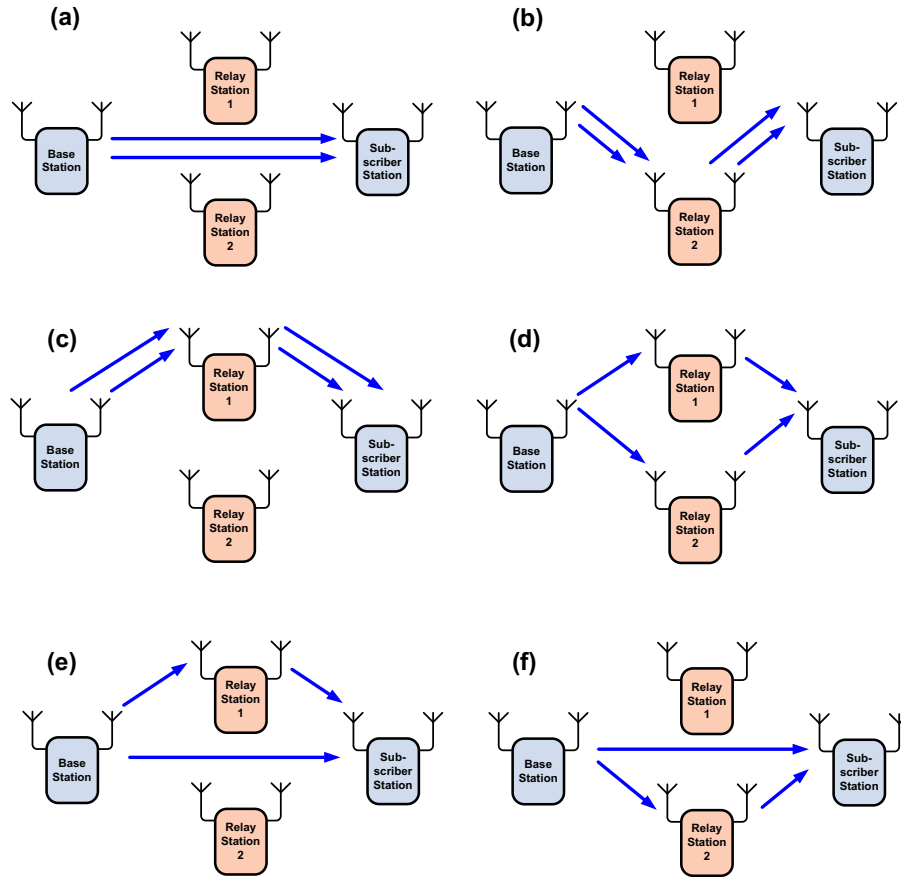

Figure 1. Different transmission modes supported by the cooperative multiple antenna demonstrator: (a) direct 2x2 MIMO transmission; (b, c) 2x2 MIMO transmission through one of the relays; (d) transmission using one spatial stream through each of the relays; (e, f) transmission using one of the relays and the direct path.

connection was taken equal to 5 MHz and the BPSK, QPSK, 16QAM and 64QAM modulations were supported. As a result, the overall maximum throughput was about 30 Mbps using two spatial streams.

The channel emulation scheme supporting arbitrary 2x2 MIMO channels between every pair of nodes was implemented. This scheme includes an additional interconnection board, which routes signals between all nodes so that every node is able to listen to the signal transmitted by every other node. After that the multiplexing of the parallel spatial streams was done in the time-division mode. The emulated frequency selective propagation channel and an additive white Gaussian noise were introduced at the node baseband during the DSP processing. The generation of the channel impulse response coefficients as well as the calculation of the TX and RX antenna weight vectors was performed offline (at the PC) and then these parameters were downloaded to the prototype.

The base station and subscriber station nodes were connected to the PCs using an Ethernet connection. The support by the demonstrator of the bidirectional transmission allowed sending of the real network traffic between the subscriber station and the base station PCs and also connection of the subscriber station PC to the Internet for testing the prototype performance in different scenarios.

The basic procedure for the prototype operation included the following steps:

1. Application running at the PC connected to the base station nodes generates channel impulse responses; transmission mode is selected and TX and RX antenna weight vectors are calculated for the generated channel realizations using the Data Splitting algorithm (or other multi-antenna algorithm); SNR value is selected and corresponding modulation and coding sets (MCS) are found using the PHY abstraction algorithm.
2. The obtained parameters {channel realizations, transmission mode with TX and RX antenna weight vectors, SNR value with corresponding MCSs} are downloaded to the corresponding prototype nodes
3. The file of the fixed size is transmitted from the base station PC to the subscriber station PC through the FTP protocol using the prototype running with the downloaded parameters.
4. When the file download is completed the obtained performance characteristics (error performance, time of transmission, throughput, etc.) are measured and communicated back to the base station PC
5. After that the base station PC changes the testing parameters (channel realization, transmission mode with TX and RX antenna weight vectors, SNR value with corresponding MCS) and performs the next iteration of the file transmission
6. After all points of interest are measured the statistical analysis is done by the BS PC to calculate the system

performance metrics and they are displayed with a GUI interface.

III. SCHEDULING AND ROUTING DEMONSTRATOR

The capability of the wireless meshed backhaul network to respond to various changes of traffic demands can be achieved through opportunistic joint scheduling and routing. Within MEMBRANE framework, a hardware demonstrator is developed providing a flexible environment where novel scheduling and routing techniques can be evaluated.

In MEMBRANE, a novel distributed opportunistic routing and scheduling algorithm has been designed and proposed for implementation [5]. The MEMBRANE Distributed Scheduling (MDS) algorithm operates in two phases. During the first phase, a utility function is calculated at each node and distributed to the closest neighbors. The distributed algorithm established through this information at each node the appropriate routing and transmission scheduling. The data are transmitted during the second phase. A variety of utility functions are possible such as metrics based on the Signal-to-Interference-to-Noise-Ratio (SINR) or on the requested throughput in a Proportional Fair (PF) manner [6]. The long term QoS and throughput can also be used to specify a utility metric. In certain cases such as the SINR case, cross-layer information from the PHY layer is required. According to the utility function selected, a different response time of the system is achieved.

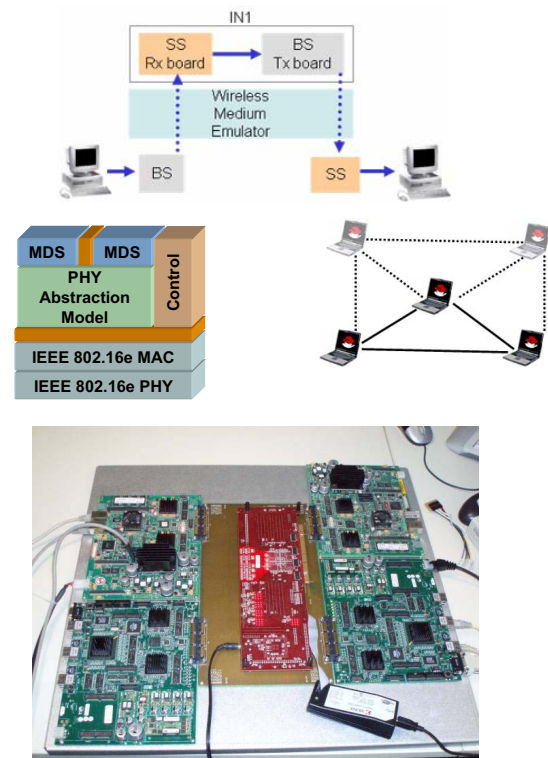

Figure 2. General block diagram of the prototype, layer composition of the nodes, representation of the “virtual” network and an image of the current setting of the hardware MEMBRANE prototype.

In order to provide a flexible environment for the effortless implementation and modification of scheduling and routing algorithms, typical IEEE 802.16e OFDMA links [7] are established between pairs of nodes of the prototype. When no direct connection is established between two nodes of the prototype, the mesh transmissions and receptions are relayed through nodes where a physical link exists. Since the aim of the prototype is the scheduling and routing entities, the mesh mode is emulated. On top of the standard PHY and MAC layer of the IEEE 802.16e links, Physical Abstraction Models are implemented in charge to emulate the expected impairments and provide the PHY inputs needed to the calculation of the utilities functions of the evaluated algorithm. A control entity is in charge to guarantee that the appropriate input values are selected and that all delays of the IEEE 802.16e links are harmonized. The following structure makes the implementation of several instances of the proposed MDS algorithm on top of the PHY abstraction model possible. Each instance can correspond to a new node forming a novel network topology composed of “virtual” nodes.

The demonstrator is composed of two typical WiMAX links, i.e. 2 pairs of BS and SS nodes. From the 4 boards, one BS and one SS boards are linked to form a relay node. A wireless medium emulator board is used for the interconnection of the prototype.

IV. CONCLUSION

The validation and evaluation of advanced algorithms and protocols designed for cross-layer optimization of meshed wireless networks can be achieved with the hardware implementation of selected novel techniques. Within the MEMBRANE framework, two demonstrators are developed to

produce proof-of-concept of multiple antenna link techniques and joint scheduling/routing protocols that aim to optimize meshed backhaul networks. The two platforms serve to demonstrate optimized mitigation of the effects of the wireless medium and flexible response behavior to variable QoS request of the backhaul network. In this paper, the implementation of the Data Splitting Algorithm and the MEMBRANE Distributed Scheduling protocol in two different commercial hardware platforms is described. The selected prototyping scheme with two set of demonstrators can be used to confirm the economical viability of the techniques investigated within the MEMBRANE project.

V. REFERENCES

- [1] IEEE 802.16-2004, “Part 16: Air interface for fixed broadband wireless access systems,” IEEE Standards Department, New York, Tech. Rep. IEEE Std 802.16-2004, Oct. 2004.
- [2] MEMBRANE Deliverable D4.1.2 “IA/MIMO-enabled Techniques for Reconfigurable Transmission and Routing”, June, 2007. Available online at <http://www.imperial.ac.uk/membrane/>
- [3] F. Boccardi, K. Yu, A. Alexiou, "A New Approach for High Data Rate Relay Transmissions," PIMRC, Athens, Greece, Sept. 2007.
- [4] Stratix II DSP Development Board Reference Manual, Altera Corporation. August 2006. Available online at <http://www.altera.com>
- [5] MEMBRANE Deliverable D4.2.1, “Joint Routing, Scheduling and Power Control Algorithm”, www.ist-membrane.org, December 2006.
- [6] Y. Hou, K. K. Leung, MEMBRANE Internal Report, “WP4.2 Distributed Scheduling Algorithm Specifications for the prototype”, February 2007.
- [7] IEEE 802.16e 2005, “Part 16: Air interface for fixed broadband wireless access systems amendment 2: Physical and medium access control layers for combined fixed and mobile operation in licensed bands and corrigendum 1,” IEEE Standards Department, New York, Tech. Rep. IEEE Std 802.16e-2005, Feb. 2006