

ADAPTIC

User Manual

Revision 1.5e

B.A. Izzuddin

September 2016

Department of Civil and Environmental Engineering
Imperial College London
London SW7 2AZ

Table of Contents

Page

CHAPTER 1. INTRODUCTION	1
1.1 TYPES OF ANALYSIS	2
1.1.1 Static analysis – proportional loading	2
1.1.2 Static analysis – time-history loading	2
1.1.3 Dynamic analysis	2
1.1.4 Eigenvalue analysis	2
1.2 STRUCTURAL MODELLING	3
1.2.1 Elastic Modelling	3
1.2.2 Plastic Hinge Modelling	3
1.2.3 Elasto-Plastic Modelling	3
1.2.4 Adaptive Elasto-Plastic Modelling	3
1.2.5 Joints and Boundary Conditions	3
1.2.6 Dynamic Characteristics Modelling	4
CHAPTER 2. USING ADAPTIC.....	5
2.1 ADAPTIC DATA FILE	5
2.2 STARTING ADAPTIC	5
2.3 ADAPTIC OUTPUT FILES	5
CHAPTER 3. MATERIAL MODELS	6
CHAPTER 4. JOINT ELEMENT CURVES	39
CHAPTER 5. CROSS-SECTION TYPES	68
CHAPTER 6. ELEMENT TYPES.....	89
CHAPTER 7. DATA SYNTAX.....	144
7.1 INTRODUCTION	144
7.2 GENERAL FACILITIES.....	145
7.2.1 Continuation	146
7.2.2 Comments	147
7.2.3 Incrementation.....	148
7.3 INPUT MODULES.....	149
7.3.1 Analysis.....	150
7.3.2 Default parameters	151
7.3.3 Materials.....	152
7.3.4 Sections.....	153
7.3.5 Patterns.....	154
7.3.6 Groups	155
7.3.7 Structural.nodal.coordinates	156
7.3.8 Non.structural.nodal.coordinates	157
7.3.9 Element.connectivity.....	158
7.3.10 Imperfections	159
7.3.11 Coupled.additional.freedoms.....	160
7.3.12 Restraints	161
7.3.13 Conditions.....	162
7.3.14 Linear.curves	163
7.3.15 Integration.scheme.....	165
7.3.16 Applied.loading.....	166
7.3.17 Equilibrium.stages	168
7.3.18 Phases.....	169
7.3.19 Iterative.strategy	171
7.3.20 Convergence.criteria	173
7.3.21 Output	175
7.3.22 Lanczos.eigenvalue.....	176

CHAPTER 8. POST-PROCESSING.....	178
8.1 START-UP.....	178
8.2 ADAPTIC_GRAPHES	179
8.2.1 General Facilities	179
8.2.2 File.....	180
8.2.3 Graphs	181
8.2.4 Customize.....	182
8.3 ADAPTIC_SHAPES	183
8.3.1 General Facilities	183
8.3.2 File.....	185
8.3.3 Shapes.....	186
8.3.4 Contours	187
8.3.5 View	188
CHAPTER 9. EXAMPLES	189
9.1 SPACE DOME SUBJECT TO VERTICAL APEX LOAD	189
9.1.1 Data file	190
9.1.2 Structural behaviour	192
9.1.3 Output file	194
9.2 K-FRAME SUBJECT TO VERTICAL LOAD.....	197
9.2.1 Data file	198
9.2.2 Structural behaviour	200
9.2.3 Output file	202
9.3 LEE'S FRAME	205
9.3.1 Data file	206
9.3.2 Structural behaviour	208
9.3.3 Output file	210
9.4 FIXED ENDED BEAM-COLUMN.....	213
9.4.1 Data file	214
9.4.2 Structural behaviour	216
9.4.3 Output file	217
9.5 TWO-STOREY FRAME	223
9.5.1 Data file	224
9.5.2 Structural behaviour	226
9.5.3 Output file	227
9.6 STEEL FRAME SUBJECT TO EXPLOSION AND FIRE LOADING	243
9.6.1 Data file	244
9.6.2 Structural behaviour	247
9.6.3 Output file	249
9.7 APEXES.....	264

Chapter 1. INTRODUCTION

ADAPTIC is an adaptive static and dynamic structural analysis program which has been developed to provide an efficient tool for the nonlinear analysis of steel and composite frames, slabs, shells and integrated structures. The program features are described briefly hereafter.

The initial development of ADAPTIC was driven by the needs of the offshore industry for an accurate yet efficient nonlinear analysis of offshore jackets subject to extreme static and dynamic loading. This motivated the development of pioneering adaptive nonlinear dynamic analysis techniques for framed structures, accounting for geometric and material nonlinearity, which formed the basis of Prof. Izzuddin's PhD thesis, and which were extensively applied in nonlinear structural analysis under earthquake loading. Since then the program has been extensively developed to deal with other extreme loading, such as fire and blast, as well as numerous additional structural forms, such as R/C and steel-decked composite slabs, cable and membrane structures, and curved shells. Most of these novel developments have been published in leading international scientific and professional journals as well as in international conferences (see <http://imperial.ac.uk/people/b.izzuddin/publications.html>).

This version of the manual (V1.5e) covers some of the main capabilities of ADAPTIC related to plane/space frames, slabs/shells and 3D continuum solid analysis. The more recent developments related to partitioned modelling for HPC will be covered in future versions. The following discussions focus on the nonlinear analysis of plane and space frames as examples of the more general nonlinear analysis capability.

Inelastic analysis of steel frames may be performed by either of two methodologies. The first is an approximate solution using ideal plastic hinge elements, while the second is a more accurate solution employing elements which account for the spread of plasticity across the section depth and along the member length. For reinforced concrete and composite frames, inelastic analysis is performed using the second approach only.

The loading can be either applied forces or prescribed displacements/accelerations at nodal points. The loads can vary proportionally under static conditions, or can vary independently in the time or pseudo-time domains. The latter variation can be utilised for static or dynamic analysis.

1.1 Types of Analysis

Loads can be applied at the nodal positions for the translational and rotational freedoms in the three global directions (X, Y, Z). A load can be an applied force or a prescribed displacement/acceleration. The only restriction on the application of loads is that a load corresponding to a structural freedom should only be specified once, and that the loaded freedom should not be restrained. This requires that ground excitation, for example, should be specified as an applied acceleration at the ground nodal freedoms, and that these freedoms should not be restrained.

Static loads applied only once to the structure at the start of analysis. Any further loads applied during proportional or time-history loading are applied incrementally on top of these loads.

The initial loads are useful for modelling the structure dead weight. Also, they can model initial support settlement through using a displacement load at a support nodal freedom.

1.1.1 Static analysis – proportional loading

These are loads which vary proportionally according to one load factor. The behaviour of a structure under proportional loading can be studied in the post-ultimate range using the displacement control strategy. These loads cannot be applied with time-history loads within the same analysis.

1.1.2 Static analysis – time-history loading

These are loads which can vary independently in the time or pseudo-time domain. As such, if the structure has reached a stage where the loads cannot be incremented as specified by the user, the analysis is terminated since the program cannot establish how the user would want to continue the analysis.

Time-history loads are useful for modelling cyclic loading under various force or displacement regimes.

1.1.3 Dynamic analysis

Dynamic loads can be specified in a similar way to time-history loads and can be applied forces or prescribed accelerations. Note that the latter allow the modelling of ground excitation, which is different from the case of static analysis where support motion is indicated by means of prescribed displacements. The ability to model loads varying independently in the time domain allows asynchronous excitation to be represented with relative ease.

1.1.4 Eigenvalue analysis

Eigenvalue analysis is performed using the efficient [Lanczos](#) algorithm, which requires as input the number of modes within the range of frequencies of interest as well as the number of iterative steps. This algorithm can also be used with dynamic analysis, where the frequencies and modes are obtained during analysis using the tangent stiffness.

1.2 Structural Modelling

The following sections describe how various analysis assumptions can be modelled using the ADAPTIC elements, which are discussed in detail in [Chapter 6](#). Note that different assumptions can be utilised in the same analysis for different members of the structure. Note also that similar element types usually exist for 2D and 3D analysis, distinguished by the last number in the element type identifier (e.g. [qph2](#) & [qph3](#))

1.2.1 Elastic Modelling

Quartic elastic elements ([qel2](#), [qel3](#)) can be used to model the beam-column effect and large displacements for selected structural members. One quartic element is capable of representing the beam-column action and large displacements for a whole member.

1.2.2 Plastic Hinge Modelling

Quartic plastic hinge element ([qph2](#), [qph3](#)) have the same elastic representation power of elements ([qel2](#), [qel3](#)) but can represent material inelasticity through the utilisation of zero-length plastic hinges at the element end nodes. The introduction of these plastic hinges depends on the interaction between the bending moments at the element ends and the axial force, established from the specification of the element [cross-section](#).

1.2.3 Elasto-Plastic Modelling

Detailed elasto-plastic modelling, based on the inelastic uniaxial material response, can be performed using cubic elasto-plastic elements ([cbp2](#), [cbp3](#)), which accurately model the spread of plasticity across the cross-section through the utilisation of material monitoring point. To represent the spread of inelasticity along the member length, a number of cubic elements, usually over 5, are required per member.

1.2.4 Adaptive Elasto-Plastic Modelling

Adaptive analysis can be applied in the elasto-plastic analysis of steel frames to reduce the modelling task, which previously required a fine mesh of cubic elements all over the structure, and to enable the analysis to be performed quite efficiently. The concept of adaptive analysis entails the utilisation of elastic quartic element ([qdp2](#), [qdp3](#)) which would sub-divide into inelastic cubic elements ([cbp2](#), [cbp3](#)) when inelasticity is detected during analysis. The analysis is started using only one quartic element per member, with element refinement performed automatically when necessary in zones along the element which are pre-defined by the user.

1.2.5 Joints and Boundary Conditions

Joint behaviour can be modelled by means of joint elements ([jel2](#), [jel3](#)) with de-coupled axial, shear and moment actions. These joint elements can have any orientation, and may utilise a number of force-displacement relationships described in [Chapter 4](#).

The joint elements may also be used to model special boundary conditions, such as inclined supports, soil-structure interaction and structural gaps, through choosing appropriate terms for the force-displacement relationships.

1.2.6 Dynamic Characteristics Modelling

The dynamic characteristics of the structure, namely mass and damping, are modelled by means of non-structural elements which must be included for dynamic analysis to be performed. The dynamic element types are:

Type	Description
<u>cnm2</u> , <u>cnm3</u>	Lumped mass elements
<u>lnm2</u> , <u>lnm3</u>	Linear distributed mass elements
<u>cbm2</u> , <u>cbm3</u>	Cubic distributed mass elements
<u>cnd2</u> , <u>cnd3</u>	Dashpot damping elements
<u>rld2</u> , <u>rld3</u>	Rayleigh damping elements

Chapter 2. USING ADAPTIC

2.1 ADAPTIC Data File

In order to perform nonlinear structural analysis using ADAPTIC, the problem data is stored in a data file which the program reads and processes. Such data specifies the structural configuration and the loading applied to structure, and must follow the syntax described in the [Data Syntax](#) chapter.

All ADAPTIC data files must have a ".dat" extension (e.g. one_storey.dat , SW_2.1.dat). A new data file may be created through modifying an existing data file or through typing the data from scratch. The former approach is usually more convenient, especially for parametric studies when only some data entries require modification.

2.2 Starting ADAPTIC

ADAPTIC currently runs on Linux workstations, where it is started using the following command:

```
{prompt} adaptic filename
```

Note that the *filename* does not include the ".dat" extension (e.g. adaptic one_storey).

ADAPTIC can also be run in the background using the following command:

```
{prompt} adaptic filename > filename.log &
```

where *filename.log* is a file which stores the job progress.

The execution of ADAPTIC invokes two successive stages. The first is a data reading stage, where the problem details are read from the data file, and several temporary files are created which incorporate problem and plotting information. The second is the analysis stage, where the information is retrieved from the temporary files and the nonlinear analysis is undertaken as specified. If the program seems to hang up before entering the reading stage, make sure that the two files *param.inc* and *stat.x* are removed from the working directory.

2.3 ADAPTIC Output Files

Upon successful completion of an ADAPTIC run, three additional files corresponding to *filename* should exist (*filename.out*, *filename.num* & *filename.plt*). The first file echoes the data file and contains the solution progress log. The second file contains the numerical results at all requested load/time steps. The third file is a plot file used by the post-processing programs.

Numerical results may be obtained through direct extraction from *filename.num*. Graphical visualisation of the results is also available through a number of post-processing programs described in the [Post-Processing](#) chapter.

Chapter 3. MATERIAL MODELS

The ADAPTIC library includes a number of uniaxial material models which can be used to model steel, concrete and other materials with similar behavioural characteristics. The models and their applicability are briefly described below, with full details given in next pages:

<u>Model</u>	<u>Applicability</u>
<u>stl1</u>	Bilinear steel model with kinematic strain-hardening
<u>stl2</u>	Multisurface steel model
<u>con1</u>	Simple trilinear concrete model
<u>con2</u>	Constant confinement concrete model
<u>con3</u>	Variable confinement concrete model

Cubic elasto-plastic formulations ([cbp2](#), [cbp3](#)) utilise the full inelastic characteristics of the above models.

Quartic plastic hinge formulations ([qph2](#), [qph3](#)) utilise only the yield characteristics of the models.

The elastic formulations utilise only the elastic characteristics of the models.

This section describes the material models available in ADAPTIC. Each model is referred to by a unique name, displayed at the top of the following pages, and requires the specification of a number of properties in the order indicated.

stl1

Description	Bilinear elasto-plastic model with kinematic strain hardening.	
No. of properties	3	
Properties	Young's modulus	(E)
	Yield strength	(σ_y)
	[Strain-hardening factor (μ)]	
Application	Uniaxial modelling of mild steel	

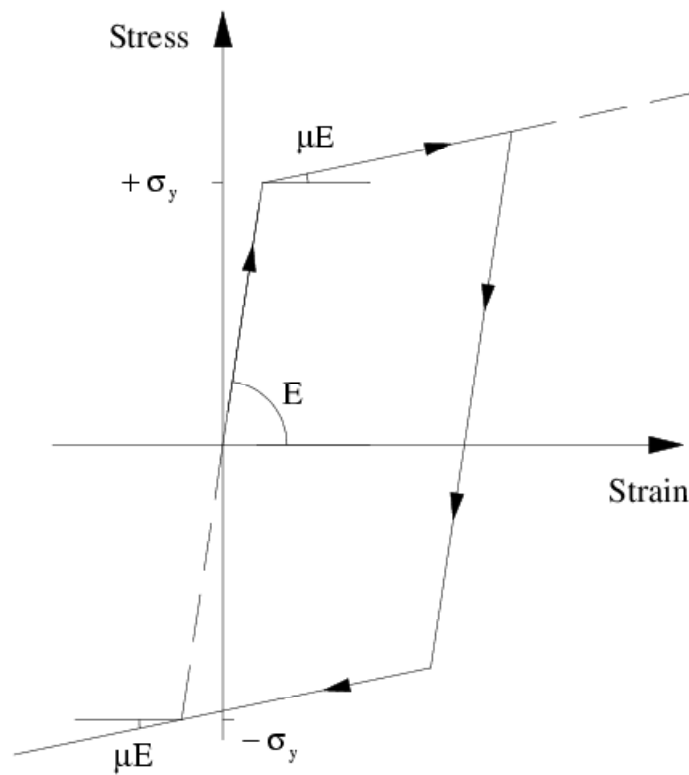

Material model stl1

Description	Multi-surface model for cyclic plasticity.
No. of properties	42
Properties	<p>Young's modulus (E)</p> <p>Plastic strains used for curves description</p> <p style="text-align: center;">$(\varepsilon_{p1}, \varepsilon_{p2}, \dots, \varepsilon_{p5})$</p> <p>Virgin stress-plastic strain properties</p> <p style="text-align: center;">$(\kappa_{a0}, \kappa'_{a0}, \kappa_{a1}, \kappa'_{a1}, \dots, \kappa_{a5}, \kappa'_{a5})$</p> <p>Cyclic stress-plastic strain properties</p> <p style="text-align: center;">$(\kappa_{b0}, \kappa'_{b0}, \kappa_{b1}, \kappa'_{b1}, \dots, \kappa_{b5}, \kappa'_{b5})$</p> <p>Weighting function properties</p> <p style="text-align: center;">$(W_0, W'_0, W_1, W'_1, \dots, W_5, W'_5)$</p>
Application	Cyclic behaviour of steel modelling hardening, softening and mean stress relaxation.
Restrictions	<p>No descending branch beyond ultimate point</p> <p style="text-align: center;">(i.e $\kappa'_{a5} > 0, \kappa'_{b5} > 0$).</p>

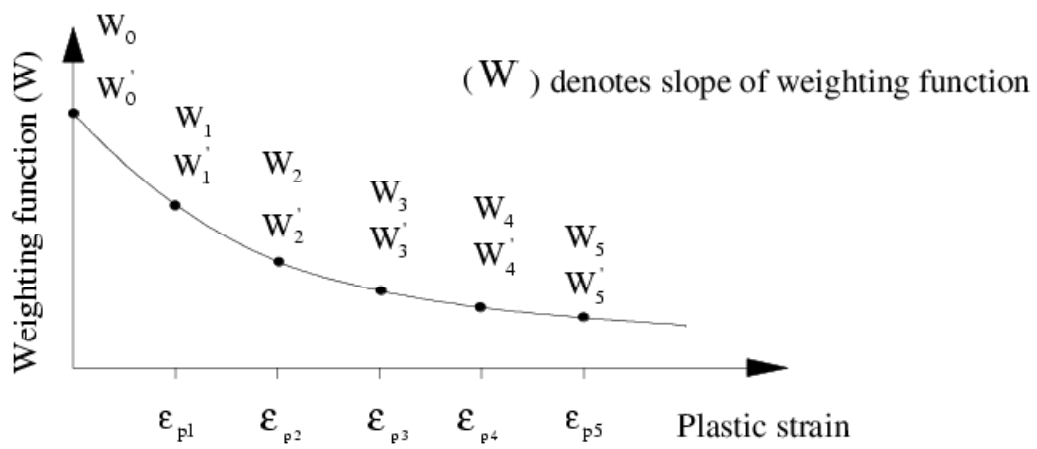
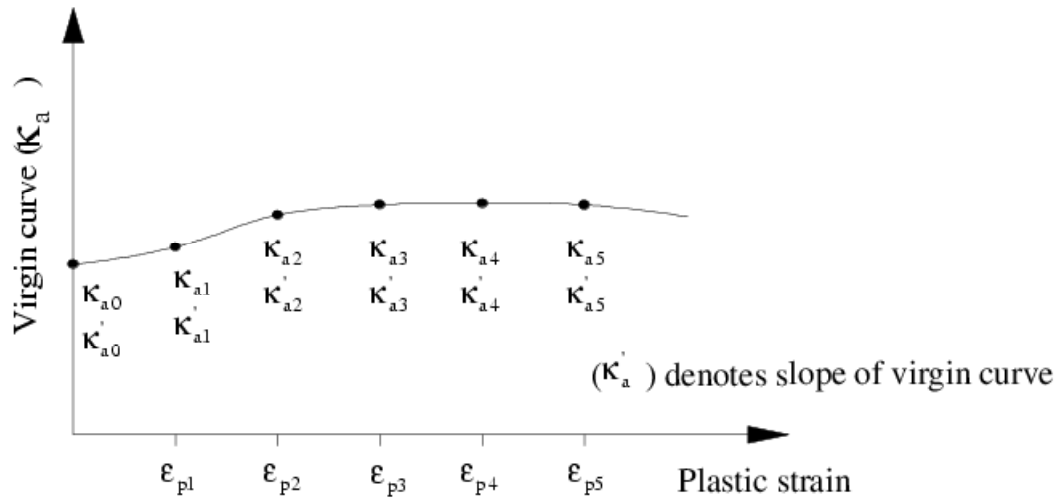

Material model stl2

stl3

Description	Rate-sensitive bilinear elasto-plastic model with kinematic strain hardening.
No. of properties	5
Properties	Young's modulus (E) Yield strength (σ_y) Strain-hardening factor (μ) Rate-sensitive parameter (S) Rate-sensitive parameter ($\dot{\epsilon}_*$)
Application	Uniaxial modelling of mild steel

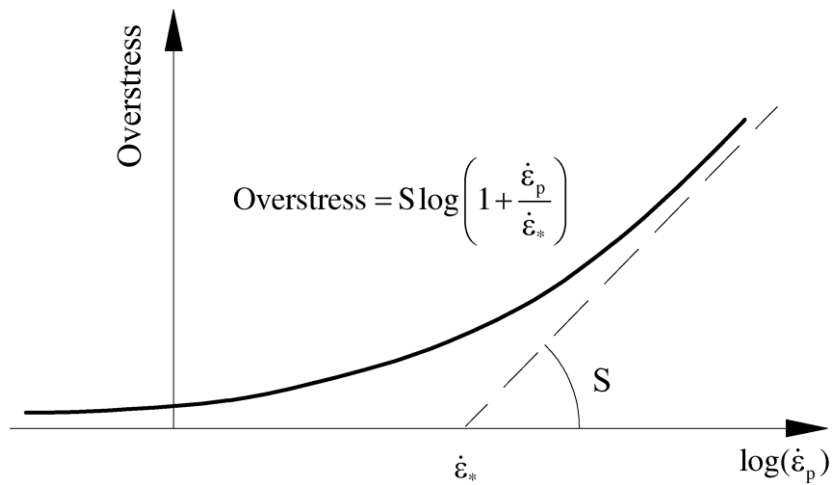

Material model stl3

Description	Bilinear material model
No. of properties	20
Properties	Young's modulus and temperatures used for trilinear description: $(E_1, E_2, T_1, T_2, T_3)$ Yield strength and temperatures for trilinear description $(\sigma_{y1}, \sigma_{y2}, T_{\sigma1}, T_{\sigma2}, T_{\sigma3})$ Strain-hardening factor and temperatures for trilinear description: $(\mu_1, \mu_2, T_{\mu1}, T_{\mu2}, T_{\mu3})$ Thermal strain and temperatures $(\alpha_1, \alpha_3, T_{\alpha1}, T_{\alpha2}, T_{\alpha3})$
Application	Requires the specification of Young's modulus, the yield strength, the strain-hardening factor, the thermal strain and their variations with temperature.
Restrictions	

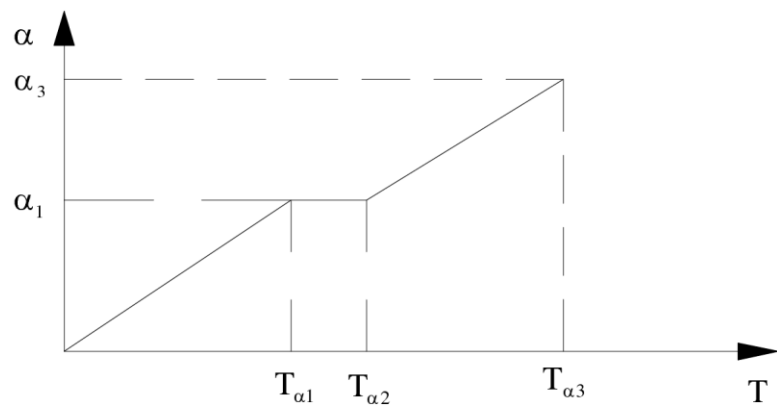
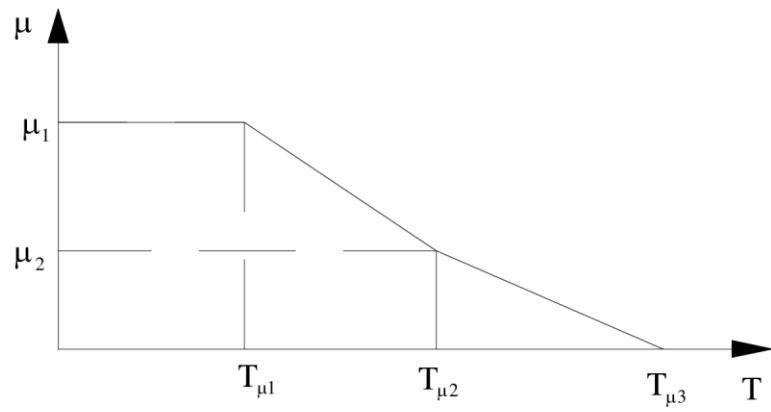
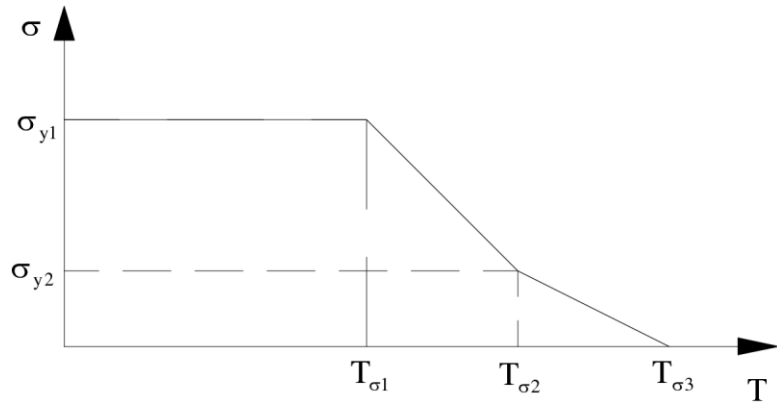

Material model stl4

stl5

<i>Description</i>	Creep model
<i>No. of properties</i>	28
<i>Properties</i>	The first 20 properties are the same as those of the bilinear model. Material constants for modelling creep (A, B, C, D, F, G, ΔH , R, σ^*)
<i>Application</i>	In addition to the 20 parameters for the bilinear material model, 8 more parameters are required to specify the creep response of the material
<i>Restrictions</i>	

Description	Elliptical model
No. of properties	37
Properties	<p>Young's modulus and corresponding temperatures $(E_1, E_2, E_3, E_4, T_1, T_2, T_3, T_4, T_5)$</p> <p>Proportional limit and corresponding temperatures $(f_{p1}, f_{p2}, f_{p3}, f_{p4}, T_{p1}, T_{p2}, T_{p3}, T_{p4}, T_{p5})$</p> <p>Yield strength and corresponding temperatures $(f_{y1}, f_{y2}, f_{y3}, f_{y4}, T_{y1}, T_{y2}, T_{y3}, T_{y4}, T_{y5})$</p> <p>Thermal strain and corresponding temperatures $(\alpha_1, \alpha_2, \alpha_3, \alpha_4, T_{\alpha1}, T_{\alpha2}, T_{\alpha3}, T_{\alpha4}, T_{\alpha5})$</p> <p>[Ultimate strain (ϵ_u)]</p>

Application requires 37 parameters in total to describe Young's modulus, the proportional limit, the yield strength, the thermal strain and their variations with temperature. The nine parameters used to define the proportional limit and its variation with temperature is illustrated in figure. The other parameters are defined in the same sequence. The ultimate strain should be $(\epsilon_u > 0.15)$ and defaults to 0.20.

Restrictions

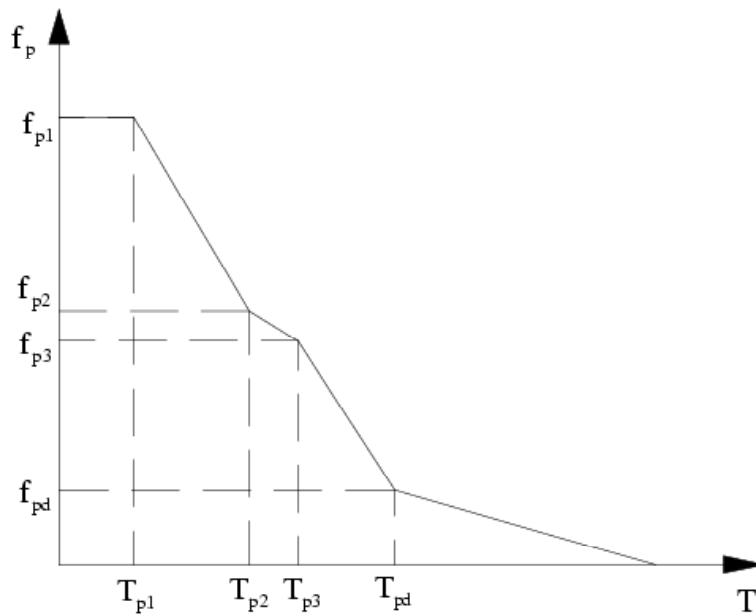

Material model *st10*

con1

Description	Trilinear concrete model, with optional tensile response and quadratic initial compressive response.	
No. of properties	8	
Properties	Secant compressive stiffness	(E_{c1})
	Compressive strength	(f_{c1})
	Compressive softening stiffness	(E_{c2})
	Residual compressive strength	(f_{c2})
	[Initial tensile stiffness	(E_{t1})
	Tensile strength	(f_t)
	Tensile softening stiffness	(E_{t2})
	[Value of $\alpha = (E_{c1}^t - E_{c1})/E_{c1}$	$([0,1])$]]
Application	Simplified uniaxial modelling of concrete material.	
Notes	E_{c1}^t is the initial tangent modulus in compression.	
	$\alpha > 0$ implies a quadratic initial compressive response.	

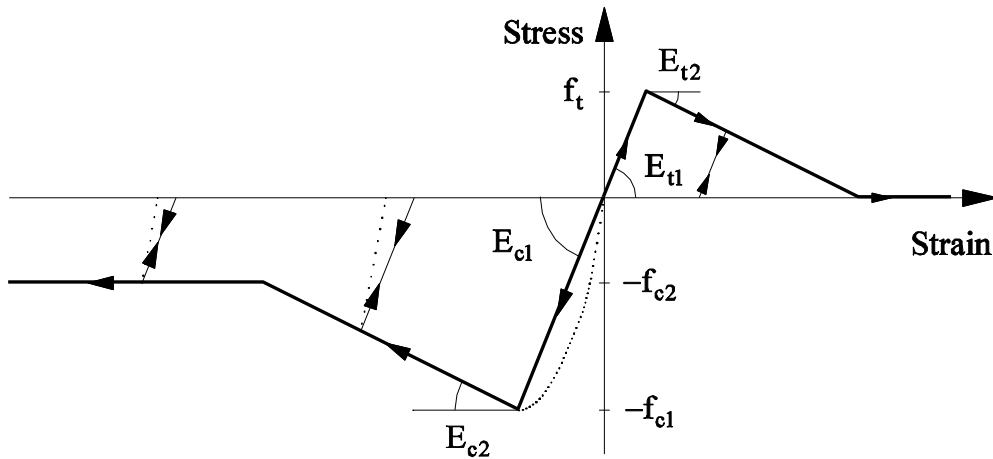

Material model con1

con2

Description	Uniaxial constant confinement concrete model.	
No. of properties	4	
Properties	Concrete compressive strength	(f_c)
	Concrete tensile strength	(f_t)
	Crushing strain	(ϵ_{co})
	Confinement factor	(k)
Application	Uniaxial modelling of concrete assuming constant confinement.	
Restrictions	Parameter units must be in Newtons and Millimetres.	
	The confinement factor must be greater or equal to 1.	

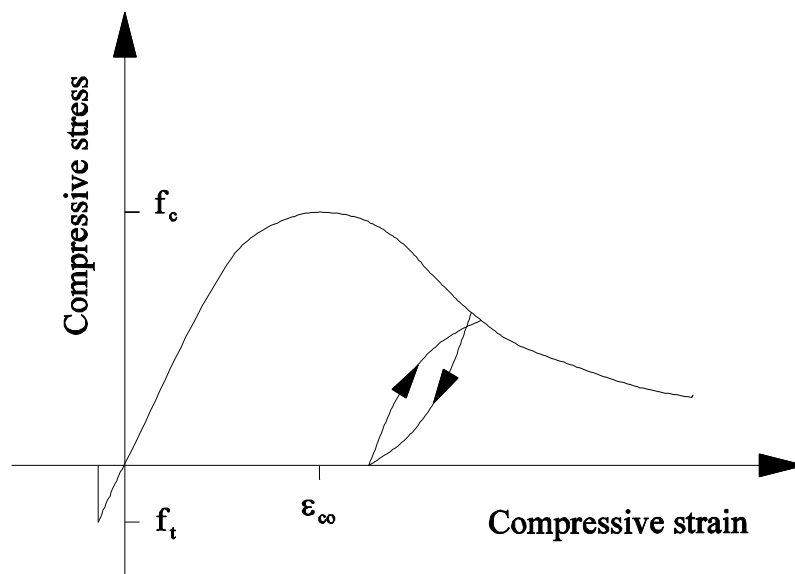

Material model *con2*

con3

Description	Uniaxial variable confinement concrete model.	
No. of properties	10	
Properties	Concrete compressive strength	(f_c)
	Concrete tensile strength	(f_t)
	Crushing strain	(ϵ_{co})
	Poisson's ratio of concrete	(ν)
	Yield stress of stirrups	(σ_y)
	Young's modulus of stirrups	(E)
	Strain hardening of stirrups	(μ)
	Diameter of stirrups	(ϕ)
	Stirrups spacing	(s)
	Diameter of concrete core	(Φ_c)
Application	Uniaxial modelling of concrete accounting for variable confinement effects, which are influenced by the core area within the stirrups, stirrups size and material, and stirrups spacing.	
Restrictions	Parameter units must be in Newtons and Millimetres.	

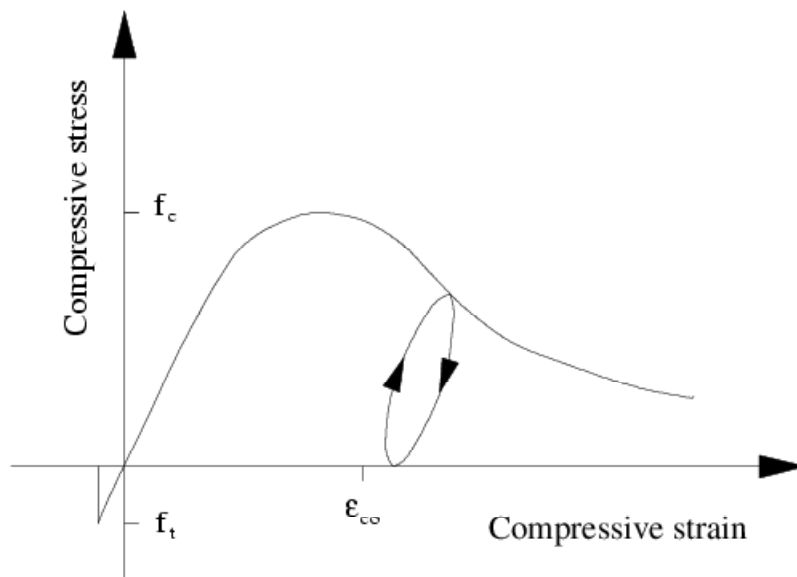

Material model **con3**

Description	Trilinear compressive concrete model for elevated temperature, with zero tensile response.
No. of properties	28
Properties	<p>Compressive strength and its reduction factors $\left(r_1 = \frac{f_{c1(T)}}{f_{c1(0)}} \right)$:</p> <p>$(f_{c1}, T_{r1,1}, r_{1,1}, T_{r2,1}, r_{2,1}, T_{r3,1}, r_{3,1})$</p> <p>Peak compressive strain and temperature factors $\left(r_2 = \frac{\epsilon_{c1(T)}}{\epsilon_{c1(0)}} \right)$</p> <p>$(\epsilon_{c1}, T_{r1,2}, r_{1,2}, T_{r2,2}, r_{2,2}, T_{r3,2}, r_{3,2})$</p> <p>Limit compressive strain and temperature factors $\left(r_3 = \frac{\epsilon_{c2(T)}}{\epsilon_{c2(0)}} \right)$</p> <p>$(\epsilon_{c2}, T_{r1,3}, r_{1,3}, T_{r2,3}, r_{2,3}, T_{r3,3}, r_{3,3})$</p> <p>Thermal strain and temperatures</p> <p>$(0(\text{unused}), T_{\alpha1}, \alpha_1, T_{\alpha2}, \alpha_2, T_{\alpha3}, \alpha_3)$</p>
Application	Requires the specification of the compressive strength, the peak compressive strain, the limit compressive strain at zero stress, the thermal strain and their variations with temperature. Note that r_2 and r_3 can be greater than 1.
Restrictions	

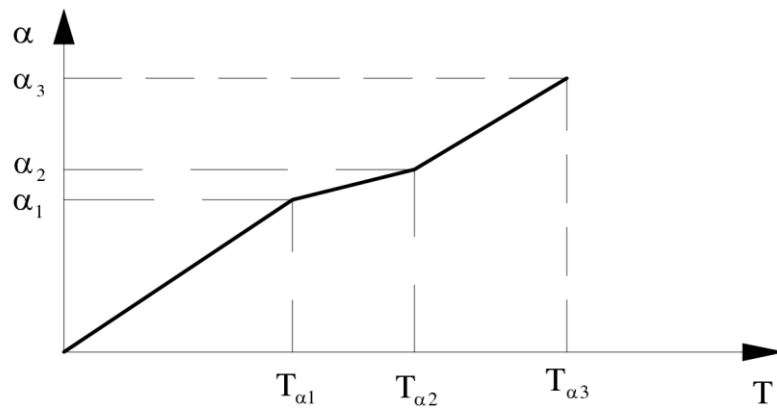
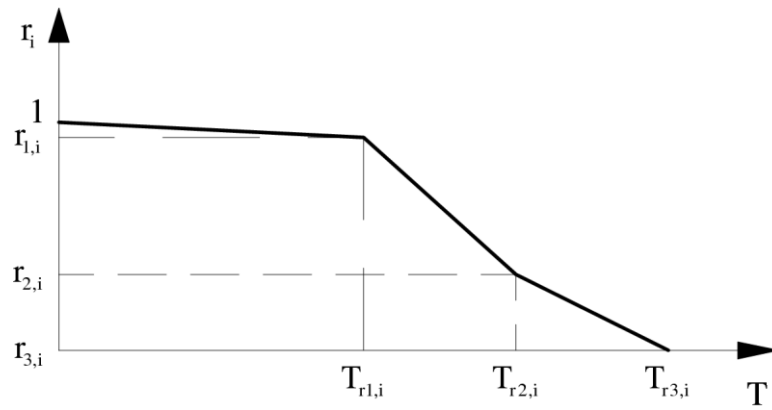
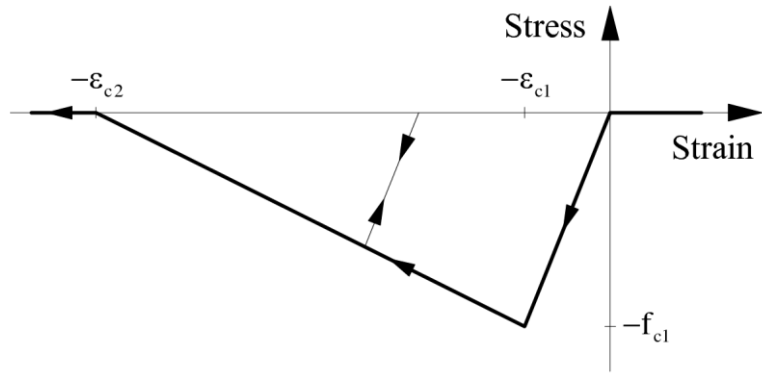

Material model con6

Description	Rotating-crack elevated-temperature model for concrete with linear compressive response.
No. of properties	25
Properties	Young's modulus and temperatures: (E_0, r_2, T_1, T_2, T_3) Poisson's ratio and temperatures: ($\nu_0, r_2, T_1, T_2, T_3$) Tensile strength and temperatures: ($f_{to}, r_2, T_1, T_2, T_3$) Softening slope and temperatures: ($E_{cr0}, r_2, T_1, T_2, T_3$) Thermal strain and temperatures ($\epsilon_{th1}, r_2, T_1, T_2, T_3$)
Application	Plasticity-based model of concrete taking account of tensile cracking and elevated temperature.
Restrictions	

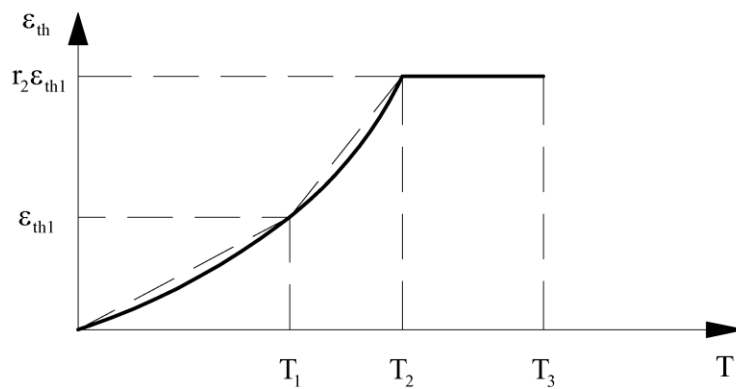
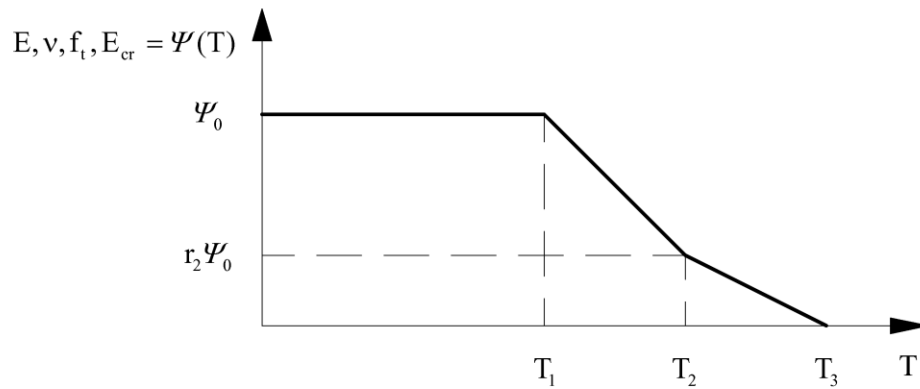
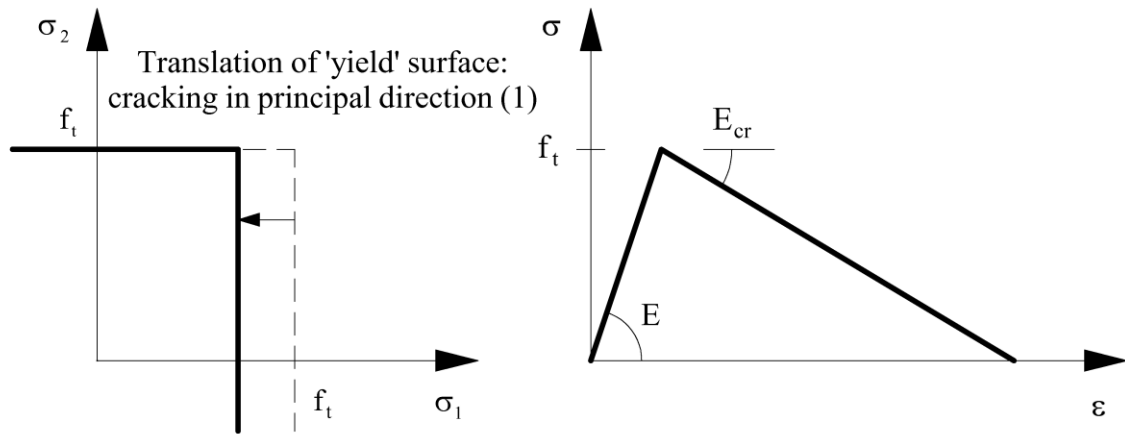

Material model con9

Description	Uniaxial concrete model for long term analysis.														
No. of properties	7														
Properties	<table border="0"> <tr> <td>Type of analysis</td> <td>1 (linear viscoelastic) 2 (brittle viscoelastic)</td> </tr> <tr> <td>Time of casting</td> <td>[days]</td> </tr> <tr> <td>Compressive strength</td> <td>[N/mm²]</td> </tr> <tr> <td>Tensile strength</td> <td>[N/mm²]</td> </tr> <tr> <td>Relative humidity of environment</td> <td>[%]</td> </tr> <tr> <td>Notional size of member *</td> <td>[mm]</td> </tr> <tr> <td>Shrinkage ratio</td> <td></td> </tr> </table>	Type of analysis	1 (linear viscoelastic) 2 (brittle viscoelastic)	Time of casting	[days]	Compressive strength	[N/mm ²]	Tensile strength	[N/mm ²]	Relative humidity of environment	[%]	Notional size of member *	[mm]	Shrinkage ratio	
Type of analysis	1 (linear viscoelastic) 2 (brittle viscoelastic)														
Time of casting	[days]														
Compressive strength	[N/mm ²]														
Tensile strength	[N/mm ²]														
Relative humidity of environment	[%]														
Notional size of member *	[mm]														
Shrinkage ratio															
Application	<p>The long-term concrete model can be employed for long-term analysis. Two different options are allowed:</p> <ul style="list-style-type: none"> - Linear viscoelastic concrete - Brittle viscoelastic concrete <p>In the linear viscoelastic analysis both creep and shrinkage phenomena are evaluated according to the CEB-FIP Model Code 90^[1]. The Volterra's integral equation is solved by developing the relaxation function in series of exponential functions and applying the trapezoidal rule^[2,3].</p> <p>In the brittle viscoelastic analysis, the concrete is considered linear viscoelastic in compression and in tension before cracking. In cracked phase a brittle law is assumed and both creep and shrinkage are not taken into account.</p>														
References	<p>[1] CEB 1993, CEB Bull. N°213/214: CEB-FIP Model Code 90. Comité Euro-International du Béton, Lausanne, Switzerland, 1993.</p> <p>[2] Amadio, C., Fragiaco, M., and Macorini, L., "A New Effective F.E. Formulation for Studying the Long-Term Behaviour of Continuous Steel-Concrete Composite Beams", Proceedings of the Fifth World Congress on Computational Mechanics (WCCM V), July 7-12, 2002, Vienna, Austria, Editors: Mang, H.A. <i>et al.</i>, Publisher: Vienna University of Technology, Austria.</p> <p>[3] Fragiaco, M., "A finite element model for long-term analysis of timber-concrete composite beams", submitted to <i>Computer & Structures</i>.</p>														

(*) Given by the ratio $2A_c/u$, where A_c is the cross section and u is the perimeter of the member in contact with the atmosphere.

Description	Fixed-crack elevated-temperature model for concrete.
No. of properties	37
Properties	<p>Young's modulus and temperatures: $(E_0, r_2, T_1, T_2, T_3)$</p> <p>Possion's ratio and temperatures: $(\nu_0, r_2, T_1, T_2, T_3)$</p> <p>Tensile strength and temperatures: $(f_{t0}, r_2, T_1, T_2, T_3)$</p> <p>Tensile softening slope and temperatures: $(a_{t0}, r_2, T_1, T_2, T_3)$</p> <p>Thermal strain and temperatures $(\epsilon_{th1}, r_2, T_1, T_2, T_3)$</p> <p>Compressive strength and temperatures: $(f_{c0}, r_2, T_1, T_2, T_3)$</p> <p>Normalised initial compressive strength: (s_c)</p> <p>Normalised residual compressive strength: (r_c)</p> <p>Normalised strain increment beyond ϵ_c: (m_c)</p> <p>Factor for biaxial compressive interaction: (b_c)</p> <p>Elastic shear retention factor: (β_s)</p> <p>Factor scaling direct tensile stresses for shear interaction: (Φ_s)</p> <p>Normalised shear softening relative to direct tensile softening: (γ_s)</p>
Application	<p>Representation of tensile cracking and compressive nonlinearity, including softening effects.</p> <p>Modelling of crack opening and closure, the latter being an important requirement under dynamic loading and fire conditions</p> <p>Consideration of the effects of elevated temperature, both in terms of the resulting thermal strains and the change of material properties</p>
Restrictions	

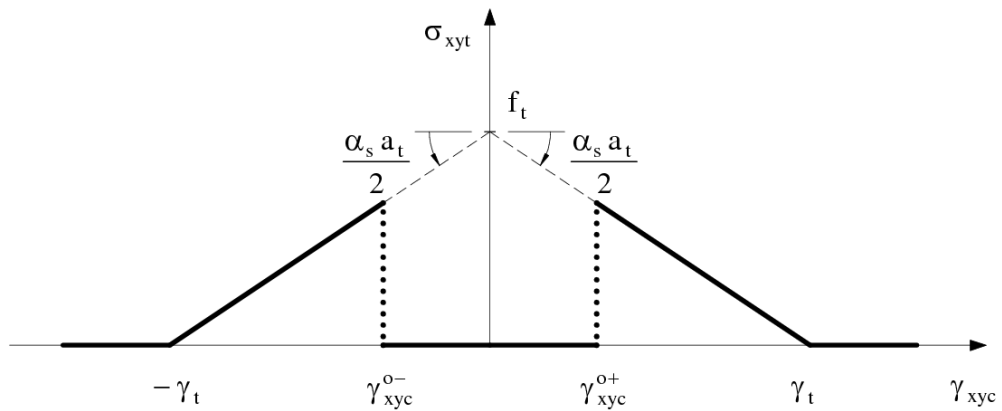
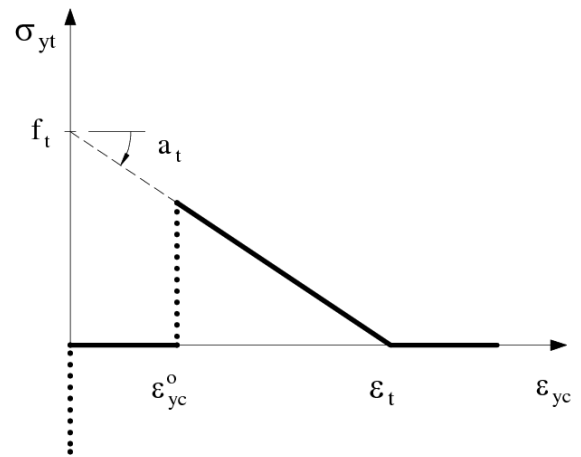
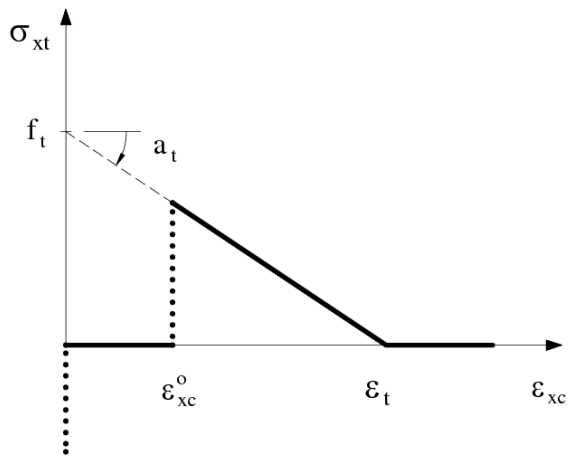
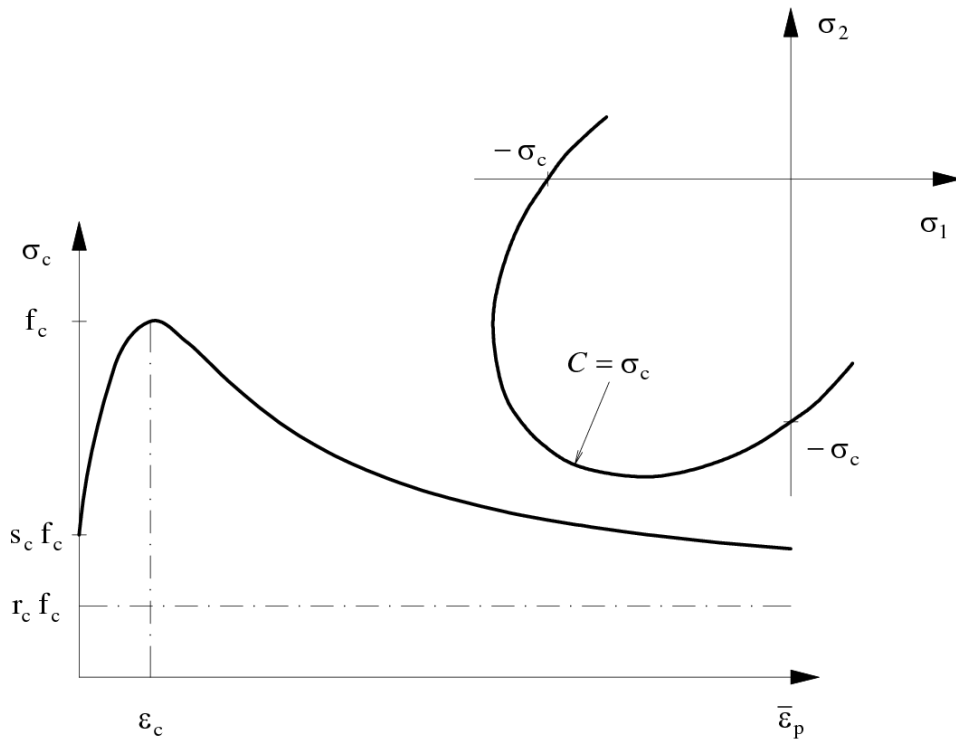

Material model *con11* (Cont'd...)

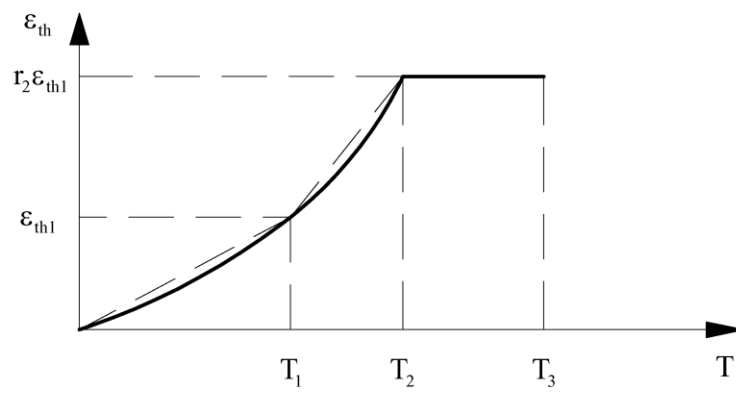
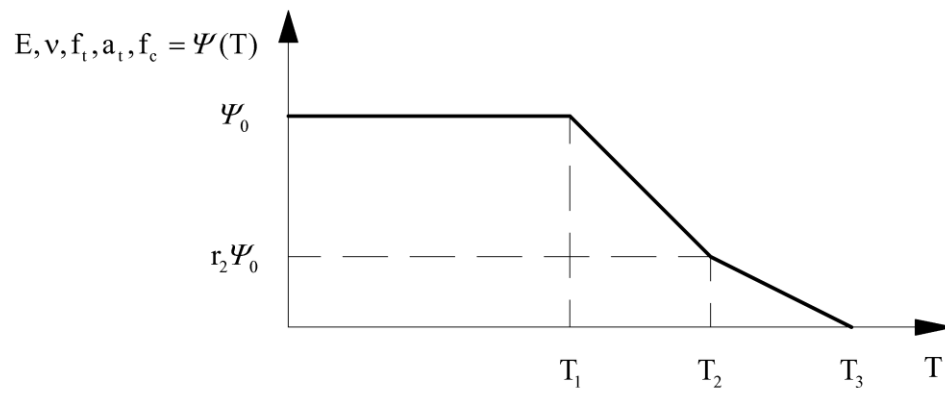

Material model con11

con12

Description	Biaxial concrete model for long term analysis, including creep, shrinkage and thermal strains.	
No. of properties	12	
Properties	Compressive strength	(f_c) [N/mm ²]
	Poisson's ratio	(ν)
	Tensile strength	(f_t) [N/mm ²]
	Tensile softening slope	(a_t) [N/mm ²]
	Elastic shear retention factor	(β_s)
	Factor scaling direct tensile stresses for shear interaction	(Φ_s)
	Normalised shear softening relative to direct tensile softening	(γ_s)
	Time of casting	(t_c) [days]
	Relative humidity of environment	(R_h) [%]
	Notional size of member	(H_o) [mm]
	Shrinkage ratio	(D_{sh})
	[Coefficient of thermal expansion	(α)]
Application	Combines creep and shrinkage model (as for con10) with fixed crack biaxial concrete model (instance of con11), considering the following: <ul style="list-style-type: none">- Linear elastic compressive reponse (f_c used only to determine elastic modulus)- If optional α is specified: $\epsilon_{th} = \alpha T$	
References	con10 and con11 .	

Description	Material properties for connection components/connected member at elevated temperature.
No. of properties	45
Properties	Ultimate strength, temperatures and reduction factors for quadlinear description: $(\sigma_u, T_{r1,1}, r_{1,1}, T_{r2,1}, r_{2,1}, T_{r3,1}, r_{3,1}, T_{r4,1}, r_{4,1})$ Young's modulus, temperatures and reduction factors: $(E, T_{r1,2}, r_{1,2}, T_{r2,2}, r_{2,2}, T_{r3,2}, r_{3,2}, T_{r4,2}, r_{4,2})$ Reduced strain hardening coefficient, temperatures and reduction factors: $(\mu_r, T_{r1,3}, r_{1,3}, T_{r2,3}, r_{2,3}, T_{r3,3}, r_{3,3}, T_{r4,3}, r_{4,3})$ Yield strength, temperatures and reduction factors: $(\sigma_y, T_{r1,4}, r_{1,4}, T_{r2,4}, r_{2,4}, T_{r3,4}, r_{3,4}, T_{r4,4}, r_{4,4})$ Strain hardening coefficient, temperatures and reduction factors: $(\mu, T_{r1,5}, r_{1,5}, T_{r2,5}, r_{2,5}, T_{r3,5}, r_{3,5}, T_{r4,5}, r_{4,5})$
Application	Requires the specification of the compressive strength, the peak compressive strain, the limit compressive strain at zero stress, the thermal strain and their variations with temperature. Note that r_2 and r_3 can be greater than 1.
Restrictions	Can be used to define material properties for joint element jbc2 .

beth

<i>Description</i>	Elastic isotropic material model with thermal strains.
<i>No. of properties</i>	3
<i>Properties</i>	Young's modulus (E) Poisson's ratio (ν) [Coefficient of thermal expansion (α)]
<i>Application</i>	Can be used for 1D, 2D and 3D elements.

Description	Biaxial/triaxial elasto-plastic material model with <i>isotropic</i> strain-hardening and material rate sensitivity.	
No. of properties	9	
Properties	Young's modulus	(E)
	Possion's ratio	(ν)
	Yield strength	(σ _y)
	Strain-hardening parameter	(μ)
	Plastic strain at onset of hardening	(ε _h)
	[Features flag	(m)
	Plastic strain at ultimate strnegth	(ε _m)
	[Rate-sensitivity parameter (1)	(S,q)
	Rate-sensitivity parameter (2)	(ε̇*, D)]]
Application	Can be used for 1D, 2D and 3D elements	
	Features flag takes the following values:	
	m = 0 : linear hardening without rate sensitivity (Default)	
	m = 1 : quaratic hardening with an ultimate strength limit	
	m = 2 : same as (m = 1) with Malvern rate sensitivity	
	m = 3 : same as (m = 1) with Cowper-Symonds rate sensitivity.	
	Ultimate strength is defined for models m=1,2,3 by:	
	$\sigma_u = \sigma_y + \frac{\mu E}{1-\mu} \frac{\epsilon_m - \epsilon_h}{2}$	
	Only default model (m = 0) is applicable to 1D.	
	Malvern rate sensitivity is defined by:	
	$\text{Overstress} = S \log \left(1 + \frac{\dot{\epsilon}_p}{\dot{\epsilon}_*} \right)$	
	Cowper-Symonds rate sensitivity is defined by:	
	$\text{Overstress} = \sigma_y \left(\frac{\dot{\epsilon}_p}{D} \right)^{1/q}$	

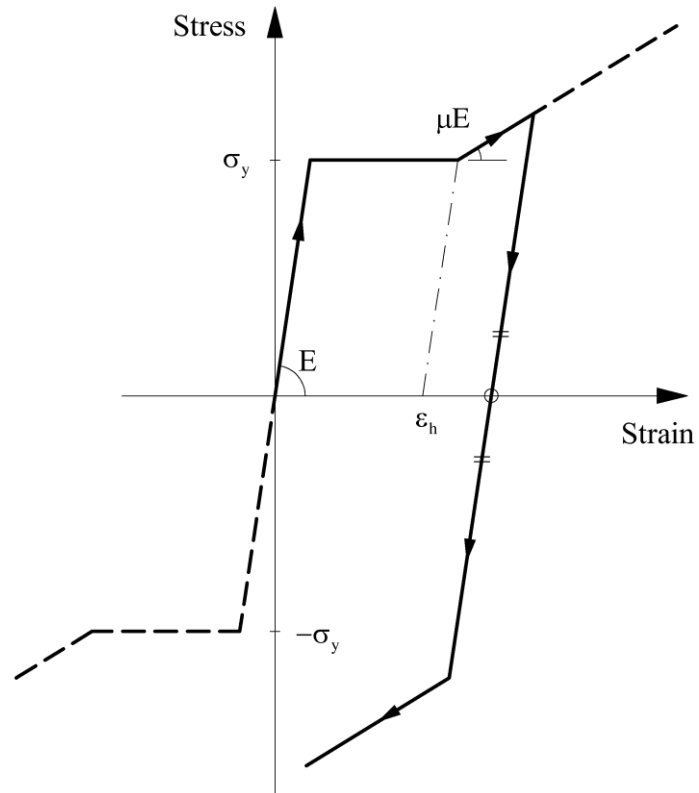

Material model *bnsi* ($m=0$)

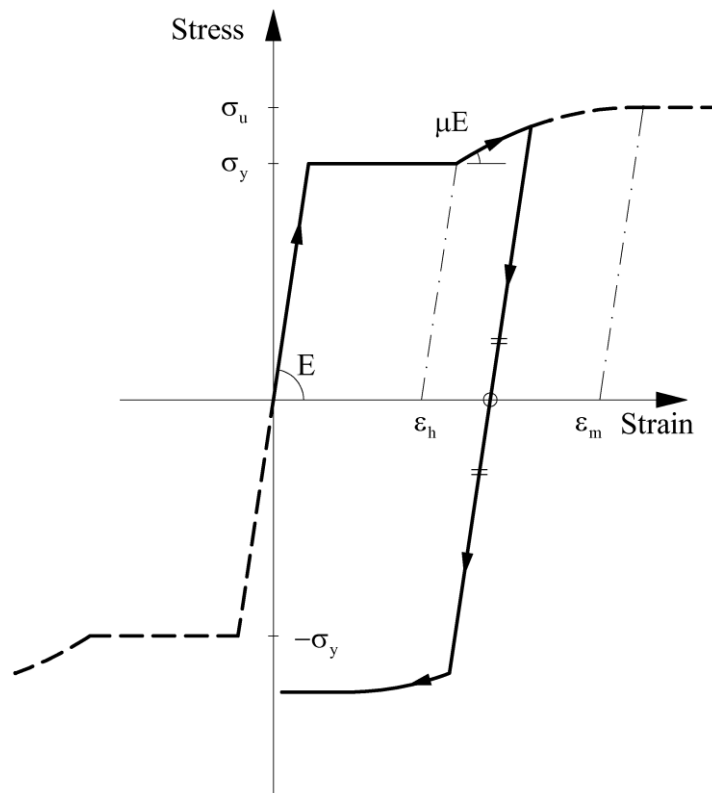

Material model *bnsi* ($m=1,2,3$)

Description	Biaxial/triaxial elasto-plastic material model with <i>kinematic</i> strain-hardening and material rate sensitivity.	
No. of properties	9	
Properties	Young's modulus	(E)
	Possion's ratio	(ν)
	Yield strength	(σ _y)
	Strain-hardening parameter	(μ)
	Plastic strain at onset of hardening	(ε _h)
	[Features flag	(m)
	Plastic strain at ultimate strength	(ε _m)
	[Rate-sensitivity parameter (1)	(S,q)
	Rate-sensitivity parameter (2)	(ε̇ _* , D)]]

Application

Can be used for 1D, 2D and 3D elements.

Features flag takes the following values:

m = 0 : linear hardening without rate sensitivity (Default)

m = 1 : quaratic hardening with an ultimate strength limit

m = 2 : same as (m = 1) with Malvern rate sensitivity

m = 3 : same as (m = 1) with Cowper-Symonds rate sensitivity.

Ultimate strength is defined for models m=1,2,3 by:

$$\sigma_u = \sigma_y + \frac{\mu E}{1-\mu} \frac{\epsilon_m - \epsilon_h}{2}$$

Only default model (m = 0) is applicable to 1D.

Malvern rate sensitivity is defined by:

$$\text{Overstress} = S \log \left(1 + \frac{\dot{\epsilon}_p}{\dot{\epsilon}_*} \right)$$

Cowper-Symonds rate sensitivity is defined by:

$$\text{Overstress} = \sigma_y \left(\frac{\dot{\epsilon}_p}{D} \right)^{1/q}$$

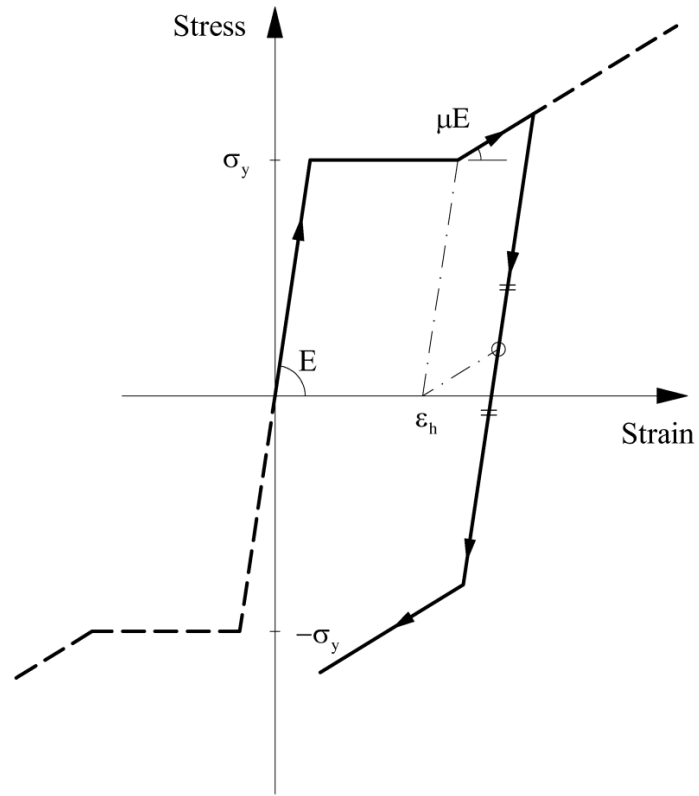

Material model *bnsk* ($m=0$)

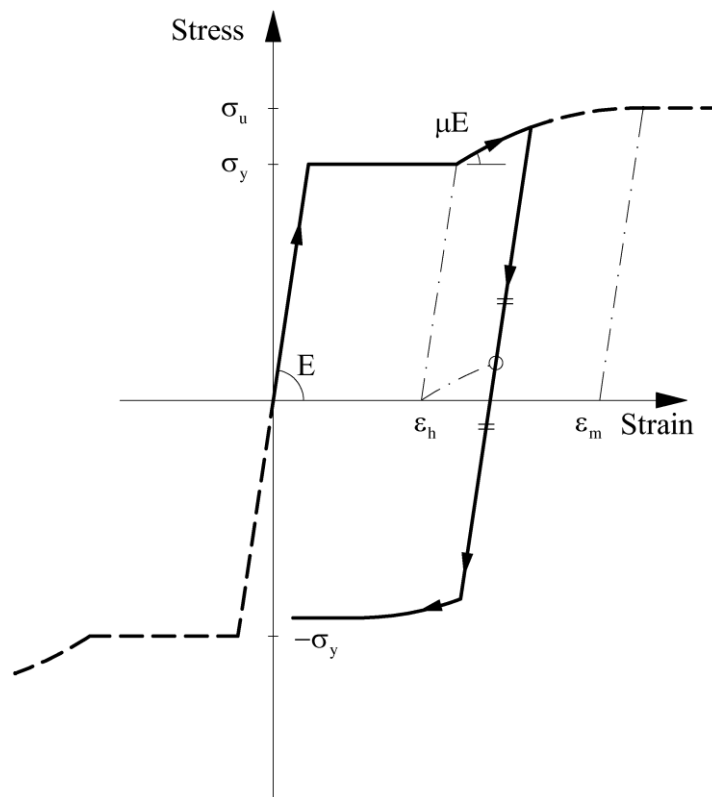

Material model *bnsk* ($m=1,2,3$)

Description	Triaxial elasto-plastic material model with <i>kinematic</i> strain-hardening and elevated temperature effects.
No. of properties	30
Properties	Young's modulus and temperatures: (E_0, E_2, T_1, T_2, T_3) Yield strength and temperatures ($\sigma_{y0}, \sigma_{y2}, T_1, T_2, T_3$) Plastic strain at onset of hardening ($\epsilon_{h0}, \epsilon_{h2}, T_1, T_2, T_3$) Strain-hardening parameter ($\mu_0, \mu_2, T_1, T_2, T_3$) Poisson's ratio and temperatures: ($\nu_0, \nu_1, \nu_2, T_1, T_2$) Thermal strain and temperatures ($\epsilon_{th1}, \epsilon_{th3}, T_1, T_2, T_3$)
Application	3D brick elements

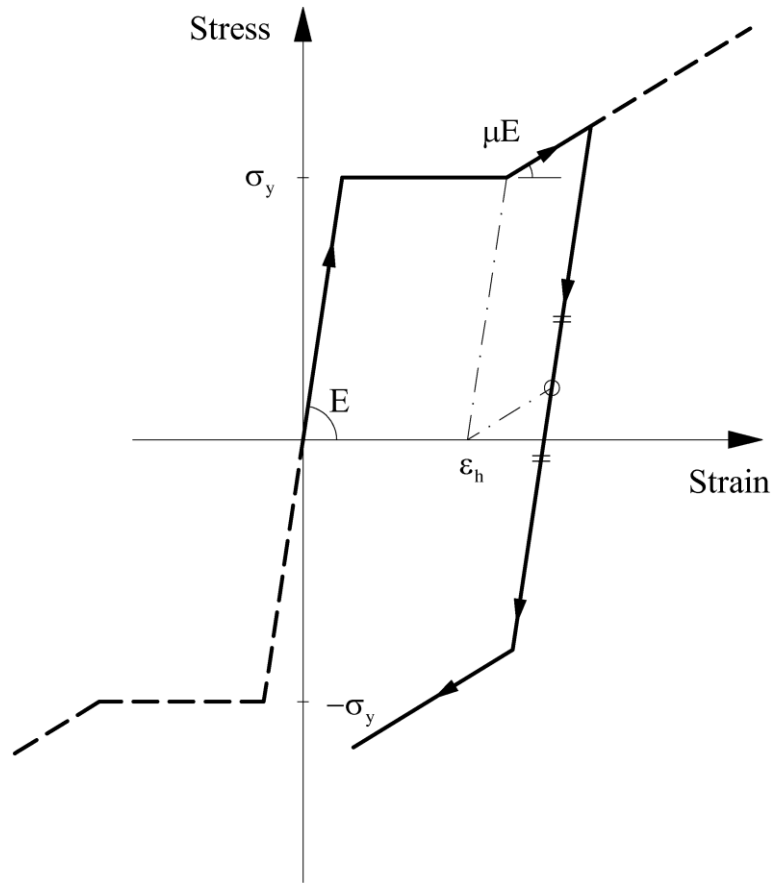

*Material model **tpth** (Cont'd...)*

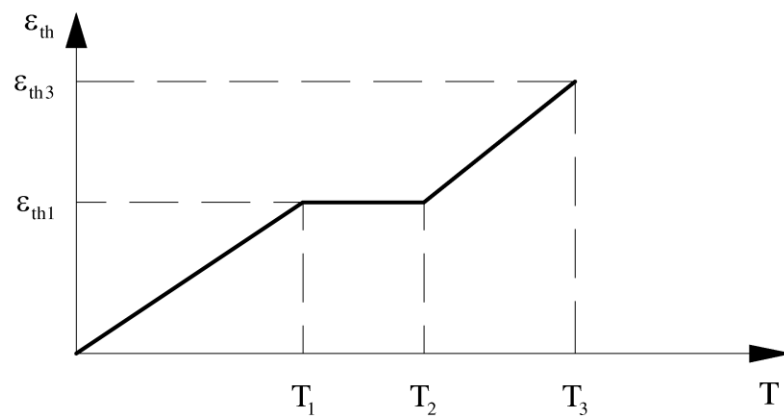
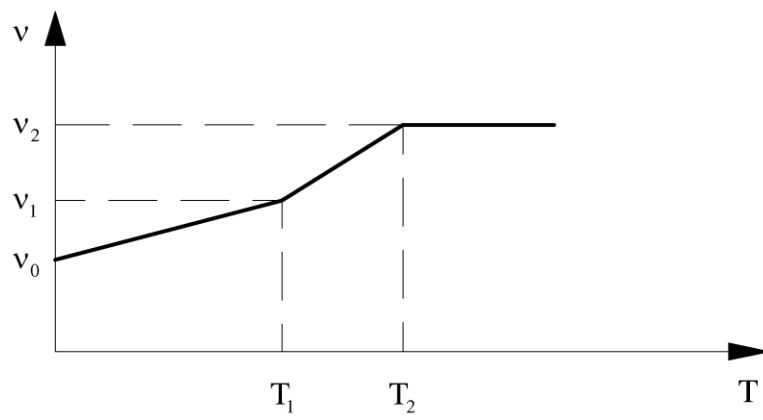
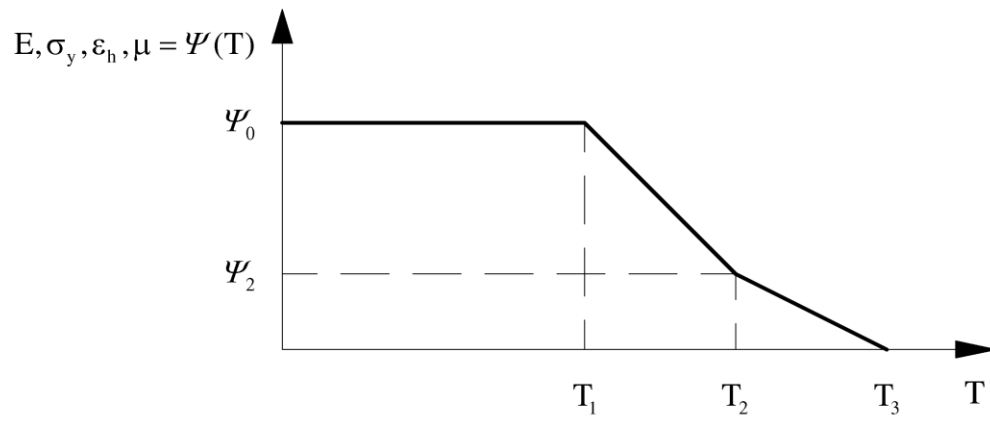

*Material model **tpth***

Description	Advanced material model for coated fabrics.	
No. of properties	19	
Properties	Half the wavelength of the warp yarn	d ₀₁
	Half the wavelength of the weft yarn	d ₀₂
	Half the thickness of the warp yarn	T ₀₁
	Half the thickness of the weft yarn	T ₀₂
	Crimp height	Z ₀₁
	Half the width of the warp yarn	b ₀₁
	Half the width of the weft yarn	b ₀₂
	Linear term material property for yarn elements	E _{A1}
	Cubic term material property for yarn elements	h ₁
	Linear term material property for crushing elements	E _{A2}
	Cubic term material property for crushing elements	h ₂
	Material property for unloading response of crushing elements	E _{Ac}
	Stiffness term for coating material	K _C
	Poisson's ratio for coating material	μ
	Shear stiffness of coated fabric	G
	E ₁₁ and E ₂₂ material properties for simple material model (Used for first iterations)	E ₁₁ ,E ₂₂
	E ₁₂ and E ₂₁ material properties for simple material model (Used for first iterations)	E ₁₁ ,E ₂₂
	Number of step reductions used in material models internal nonlinear solution procedure	N
	Key allowing friction to be included or not	k
Application	Tensioned fabric structures modelled with membrane elements The yarn elements axial force is given by: $F_A = EA_1 \varepsilon_A + EA_1 h_1 \varepsilon_A^3$ The yarn crushing elements force is given by: $F_C = EA_2 \varepsilon_C + EA_2 h_2 \varepsilon_C^3$	

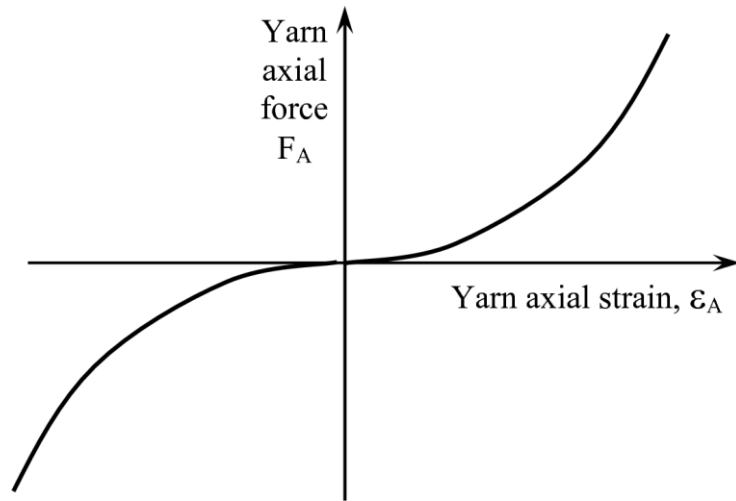

Axial response of yarn elements

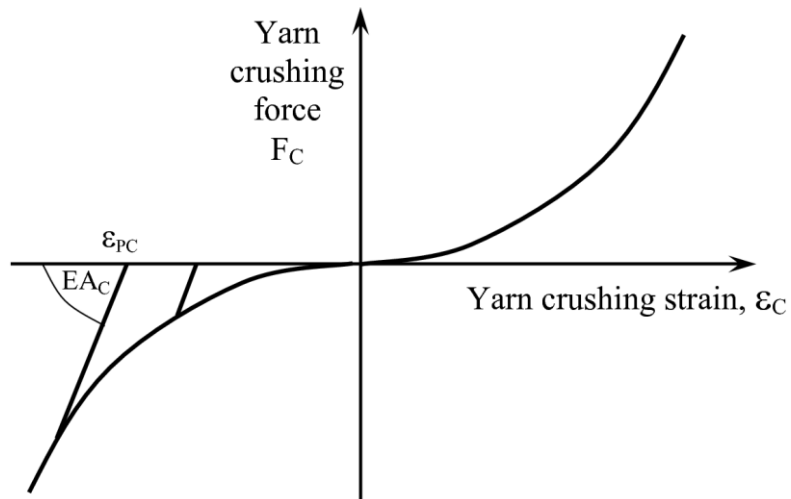

Crushing response of yarn elements

Material model tfs1 (Cont'd...)

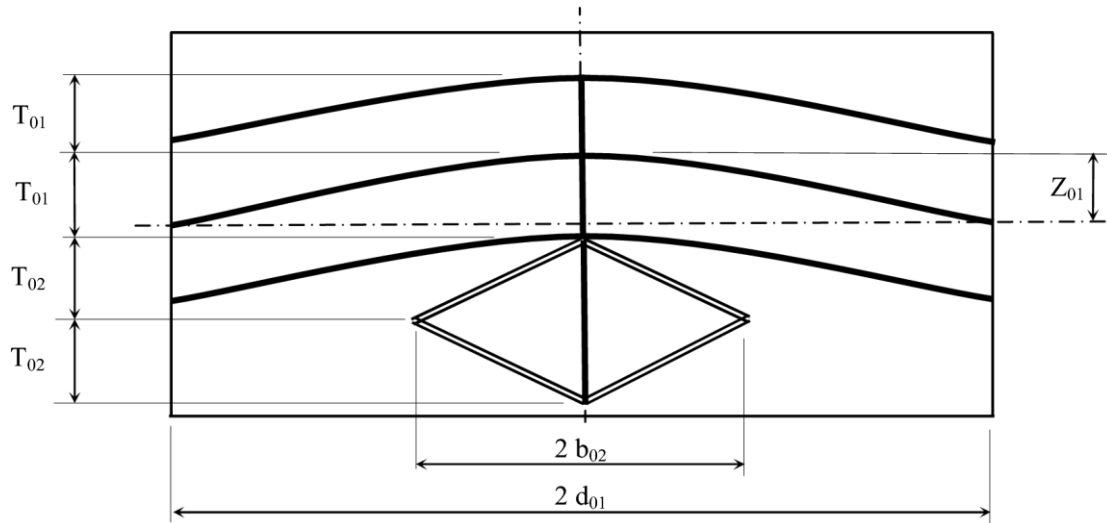

Unstrained cross section of warp yarn

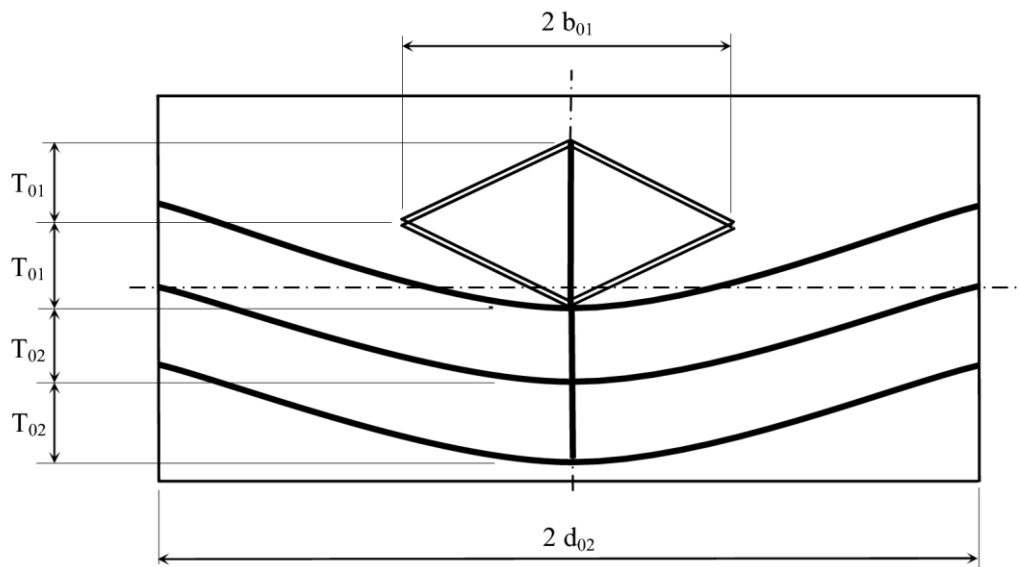

Unstrained cross section of weft yarn

Material model tfs1

Chapter 4. JOINT ELEMENT CURVES

This section describes the force-displacement curves available in ADAPTIC for use by joint elements. Each curve is referred to by a unique name, displayed at the top of the following pages, and requires the specification of a number of parameters.

lin

Description	Linear elastic curve type.
Parameters	k_0
Characteristics	Linear elastic curve.
Application	Elastic joint action characteristics.
Restrictions	

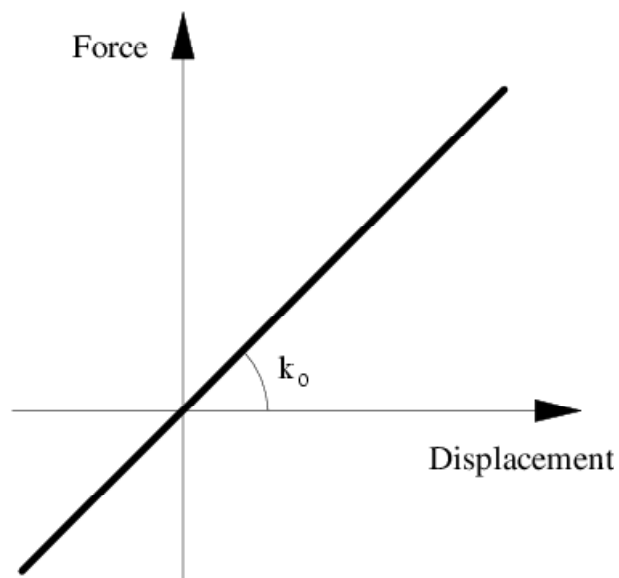

*Force-displacement curve **lin***

smtr

Description	Trilinear symmetric elasto-plastic curve type.
Parameters	k_0 , d_0 , k_1 , d_1 & k_2 , specified in this order.
Characteristics	Trilinear symmetric elasto-plastic curve. Unloading is performed kinematically to the extension of the second branch of the curve.
Application	Elasto-plastic joint action.
Restrictions	k_0 and k_1 must be positive. k_1 & k_2 must not be more than k_0 .

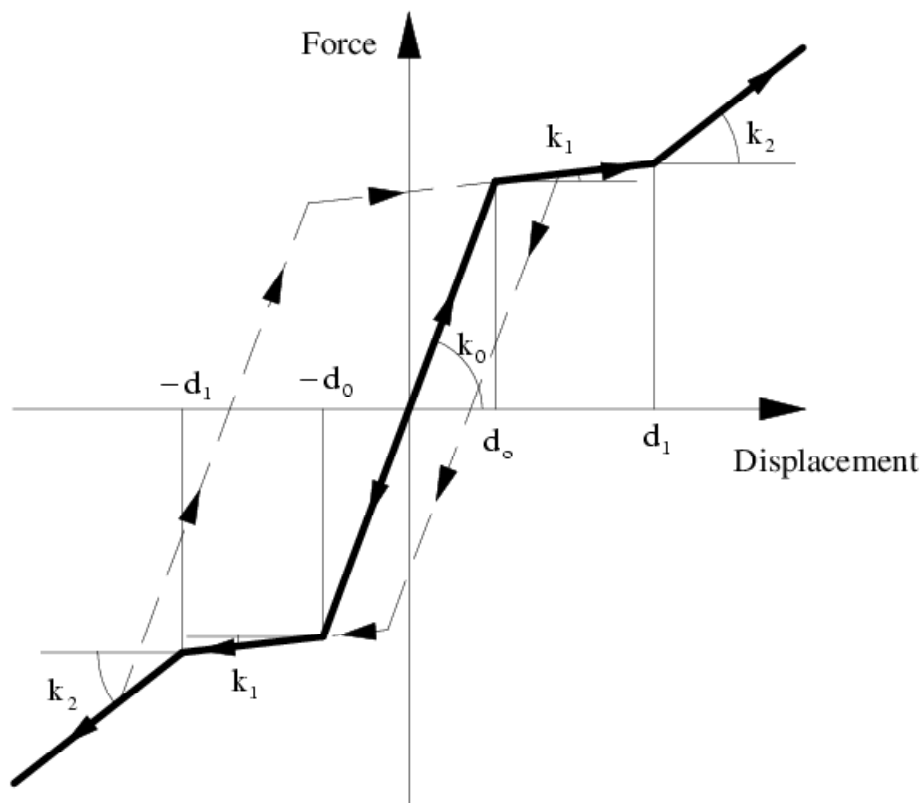

Force-displacement curve smtr

Description	Trilinear asymmetric elasto-plastic curve type.
Parameters	$(k_0, d_0, k_1, d_1, k_2)^+$ & $(k_0, d_0, k_1, d_1, k_2)^-$ specified in this order.
Characteristics	Trilinear asymmetric elasto-plastic curve. Unloading is performed kinematically to the extension of the second branch of the reloading curve.
Application	Elasto-plastic joint action. Structural gaps. The following parameters represent a curve with zero resistance until a specific negative displacement $-D$ is achieved: $(?, 0, 0, ?, 0, ?, 0, 0, -D, ?)$
Restrictions	k_0 and k_1 must be positive. k_1 & k_2 must not be more than k_0 for the positive and negative displacement regions.

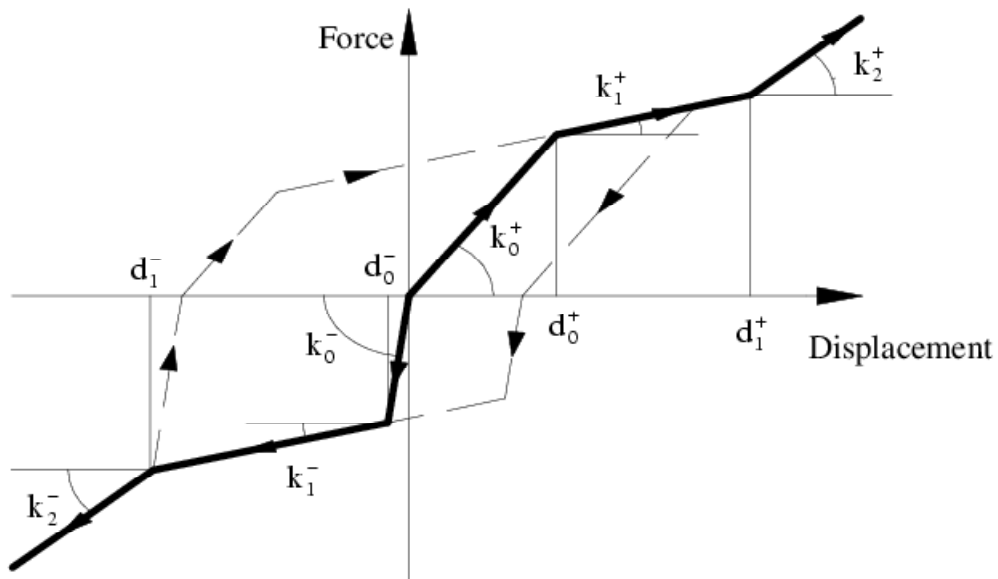

Force-displacement curve astr

rigid

Description	Rigid curve type.
Parameters	None.
Characteristics	Rigid curve.
Application	Constrains a local freedom to zero. Avoids numerical problems that can occur with the lin curve type using a large stiffness.
Restrictions	

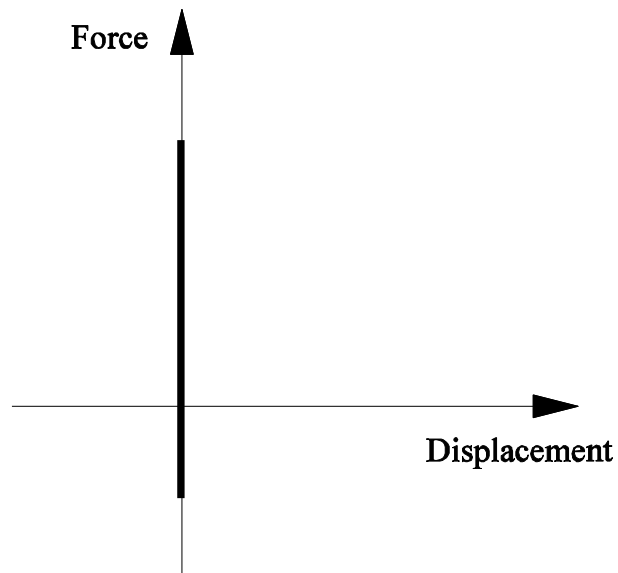

*Force-displacement curve **rigid***

contact

Description	Contact curve type.
Parameters	d_0^- & d_0^+ .
Characteristics	Gap-contact curve, with a gap between d_0^- and d_0^+ .
Application	Modelling of gaps with arbitrary lower/upper limits.
Restrictions	

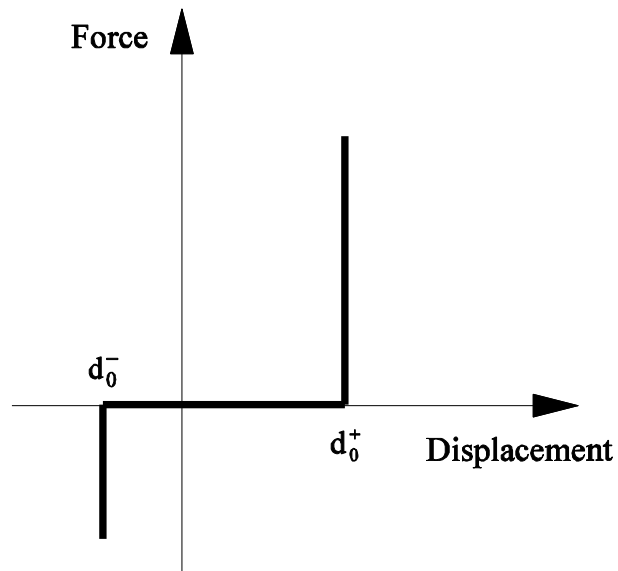

*Force-displacement curve **contact***

plastic

Description	Plastic curve type.
Parameters	F_0^- & F_0^+ .
Characteristics	Rigid plastic curve, with plastic limits F_0^- & F_0^+ .
Application	Modelling of rigid response with arbitrary lower/upper plastic limits.
Restrictions	

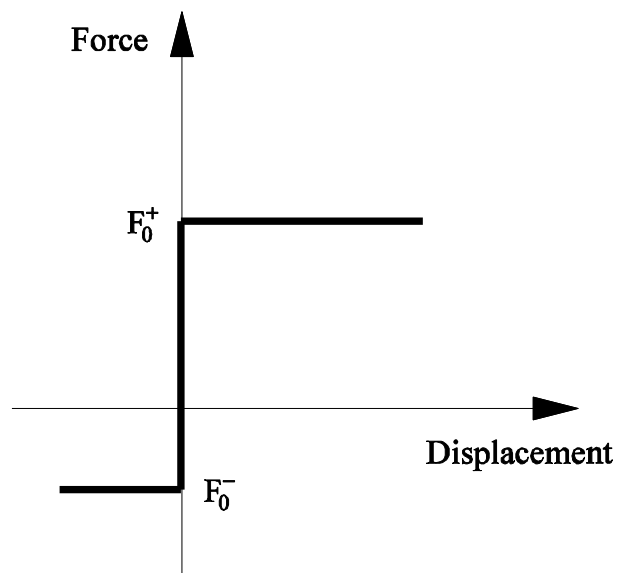

Force-displacement curve plastic

radcont

Description	Radial contact curve.
Parameters	$(d_v^- \text{ \& } d_v^+)$ or $(d_w^- \text{ \& } d_w^+)$.
Characteristics	Coupled gap-contact curve between local v and w freedoms. Elliptical gap.
Application	Contact between concentric circular tubular members, for which the gap is defined by a circle.
Restrictions	Element type jel3 . To be used simultaneously for local v and w freedoms.

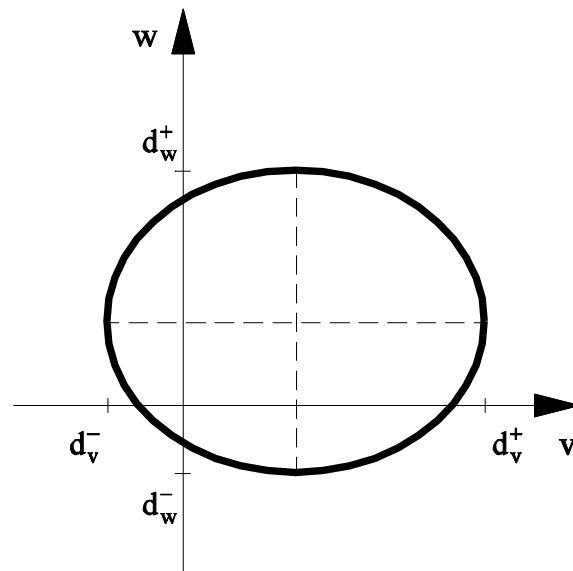

*Contact gap for curve **radcont***

Description	Smooth Hysteretic model for the panel zone response developed by Kim and Engelhardt [1].
Parameters	Specified in this order: Ke =Stiffness of the elastic branch My =Yielding moment K1 =Stiffness of the 1 st post elastic branch M1 =Moment at the end of the 1 st post elastic branch K2 =Stiffness of the 2 nd post elastic branch M2 =Moment at the end of the 2 nd post elastic branch K3 =Stiffness of the 3 rd post elastic branch Mcf =Reference Moment for the column flange Ur =Ultimate rotation CSI =Csi Parameter for the steady loops 1.1:1.2.
Characteristics	Smooth Hysteretic model with cyclic hardening, softening and relaxation. See reference [1] for a complete description of the model and it's formulation.
Application	Beam to column welded joint modelling (as a rotational spring) Panel zone Modelling (as an axial spring).
Restrictions	All parameters must be positive with: $K3 < K2 < K1 < K_e$ $M2 > M1 > M_y$
References	[1] Kee Dong Kim, Michael D. Engelhardt - Monotonic and cyclic loading models for panel zones in steel moment frames, Journal of Constructional Steel Research 58 (2002) 605-635.

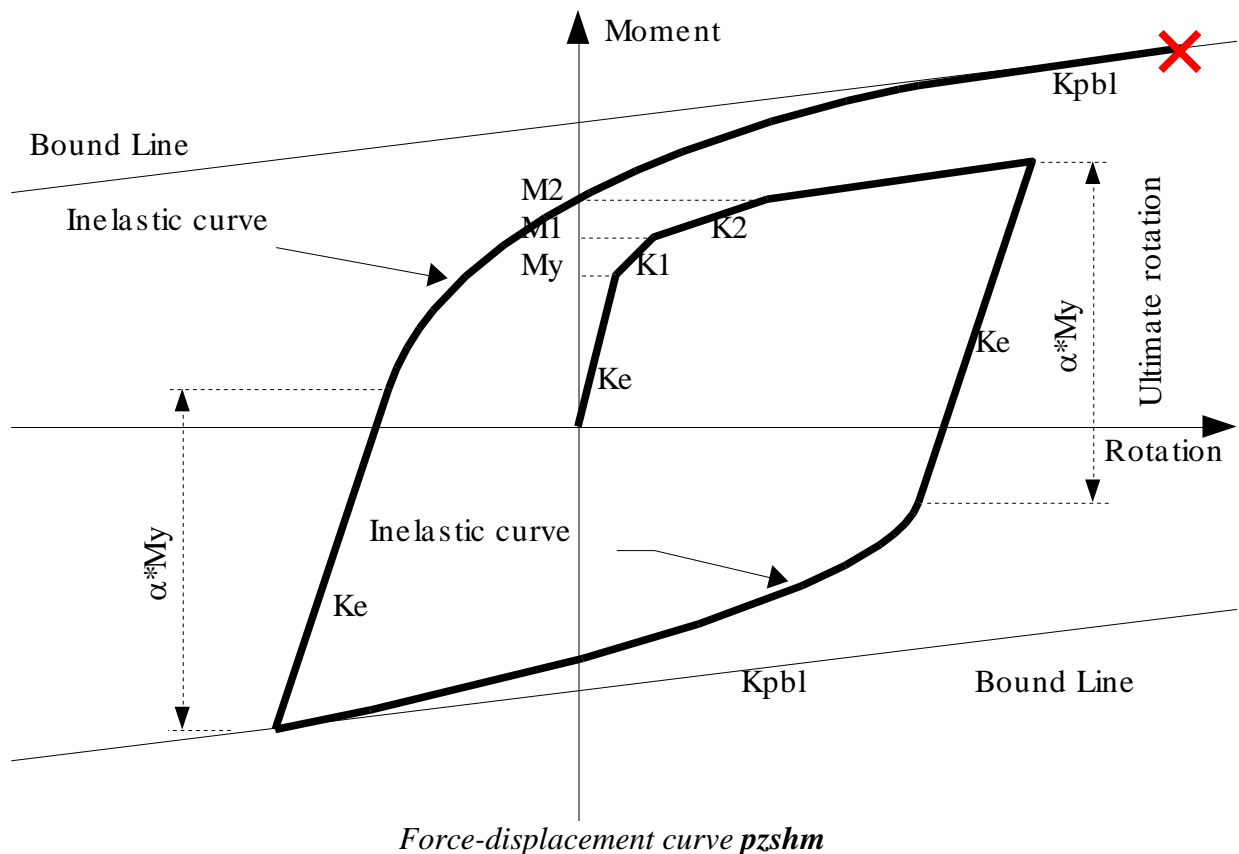

Description	Polygonal Hysteretic model for the equivalent T-stub developed by Clemente et al. [1].
Parameters	Specified in this order: Ke =Stiffness of the elastic branch Fy =Yielding force K1 =Stiffness of the 1st post elastic branch F1 =Force at the end of the 1st post elastic branch K2 =Stiffness of the 2nd post elastic branch Ud =Ultimate displacement Kc =Compression stiffness γ = 1 st strength degradation parameter δ = 2 nd strength degradation parameter Δ um=Monotonic ultimate displacement (used only for the strength degradation) ε = 3 rd strength degradation parameter α =Takeda's stiffness degradation parameter.
Characteristics	Polygonal Hysteretic model with strength and stiffness degradation.
Application	Equivalent T-stub modeling.
Restrictions	All first seven parameters must be positive (>0) $0 < K2 \leq K1 < Ke$ $F1 > Fy > 0$ $Ud > 0$ $Kc > 0$ All strength degradation parameters must be non negative (≥ 0) $1 > \gamma \geq 0$ $\delta \geq 0$ $\Delta um \geq 0$ $\varepsilon \geq 0$ Takeda's stiffness \square degradation parameter must be: $1 > \alpha \geq 0$
References	[1] Clemente I., Noè S. and Rassati G.A., 2005. Experimental and numerical analyses of the cyclic behavior of T-stub components. Proceedings of the 20th C.T.A., Ischia, 193-200.

Formulation

Stiffness degradation according to Takeda's model:

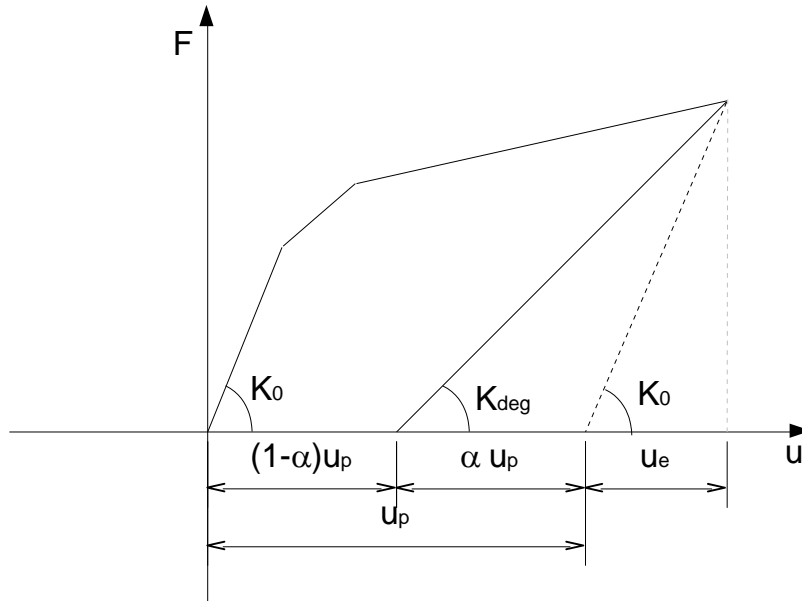

$$K_{deg} = \frac{F_{max}}{\frac{F_{max}}{K_0} + \alpha \cdot U_p}$$

where:

- K_0 =Initial Elastic Stiffness (K_e)
- F_{max} =Maximum Force Experienced
- U_{max} =Maximum Displacement
- U_p =Plastic deformation
- α =Degradation parameter ($0 \leq \alpha < 1$)

Multi-Parametric Strength Degradation:

$$\Delta F = F_y \cdot \gamma \cdot \left[1 - \left(1 - \left(\frac{E_p}{E_{um} + E_p} \right)^\delta \right) \cdot \left(1 - \left(\frac{u_{max}}{\Delta_{um}} \right)^\varepsilon \right) \right]$$

where:

- F_y =Yielding force
- γ =1st strength degradation parameter ($0 < \gamma < 1$)
- E_p =Dissipated energy
- E_{um} =Dissipated Energy in a Monotonic Loading
- U_{max} =Maximim displacement
- Δ_{um} =Ultimate Displacement in a Monotonic Loading
- δ = 2nd Strength degradation parameter
- ε = 3rd Strength degradation parameter.

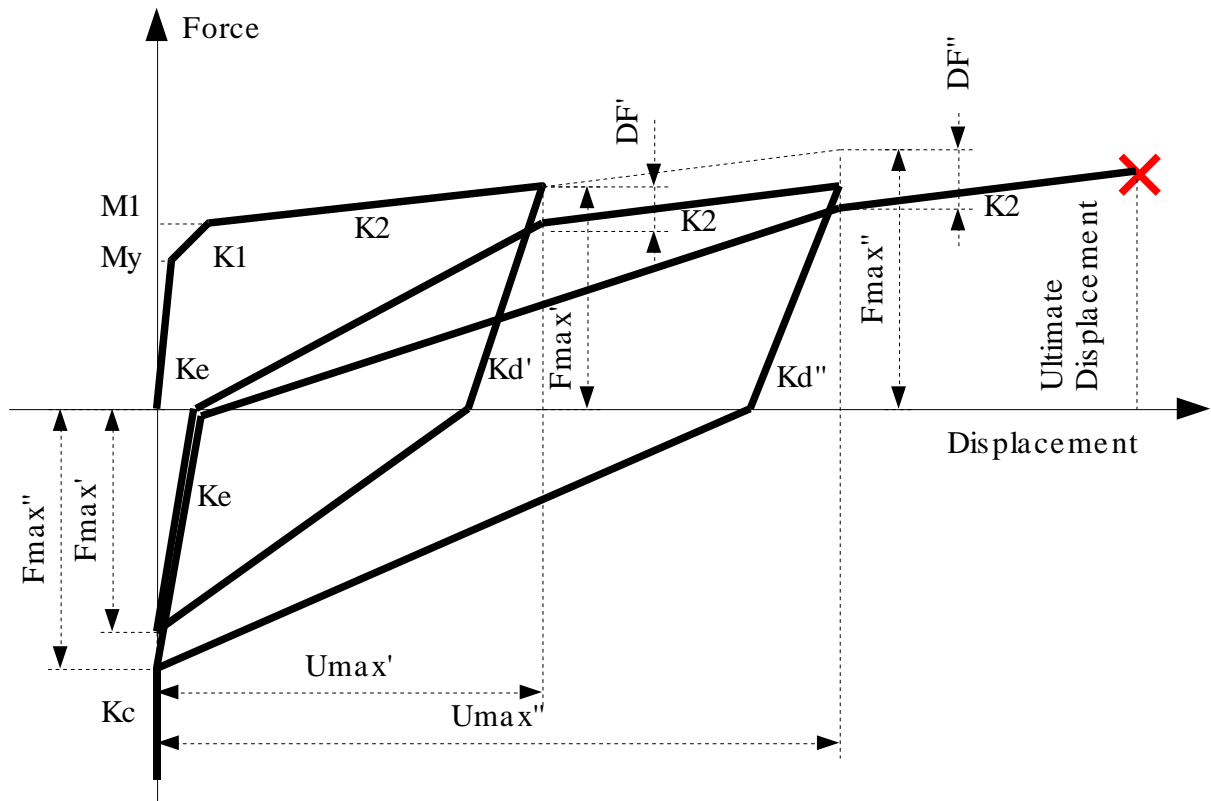

*Force-displacement curve **tstub***

Description	Polygonal hysteretic model based on the pivot rule proposed by Park et al. [1], modified to prevent stiffness increase in decreasing load cycles [2].
Parameters	Specified in this order: K _{ep} = positive elastic branch stiffness F _{yp} = positive yielding force K _{pp} = second positive branch stiffness F _{pp} = force at the end of the second positive branch K _{hp} = stiffness of the third positive branch K _{en} = negative elastic branch stiffness F _{yn} = negative yielding force K _{pn} = second negative branch stiffness F _{pn} = force at the end of the second negative branch K _{hn} = stiffness of the third negative branch U _{up} = ultimate positive displacement U _{un} = ultimate negative displacement α_1 = pivot parameter ($\alpha > 1$) β_1 = pivot parameter ($0 < \beta < 1$) γ_1 = positive strength degradation parameter α_2 = pivot parameter ($\alpha > 1$) β_2 = pivot parameter ($0 < \beta < 1$) γ_2 = negative strength degradation parameter ϵ_1 = positive strength degradation parameter (energy) ϵ_2 = negative strength degradation parameter (energy) U _{mp} = positive monotonic ultimate displacement for strength degradation U _{mn} = negative monotonic ultimate displacement for strength degradation δ_1 = positive strength degradation parameter (displacement) δ_2 = negative strength degradation parameter (displacement).
Characteristics	Polygonal Hysteretic model based on the “Pivot Rule” proposed by Park et al. and modified to prevent stiffness increase in decreasing load cycles and using multi-parametric strength degradation.
Application	General symmetric or non symmetric model with pinching and stiffness degradation.
Restrictions	All stiffness parameters must be positive (>0) $0 < K_{hp} < K_{pp} < K_{ep}$ $0 < K_{hn} < K_{pn} < K_{en}$ Positive forces and displacement must be positive (>0) F _{pp} > F _{yp} > 0 U _{up} > 0 Negative forces and displacement must be negative (<0)

$$F_{pn} < F_{yn} < 0$$

$$U_{un} < 0$$

Pivot rule parameters must be:

$$\alpha_1 > 1$$

$$0 < \beta_1 < 1$$

$$\alpha_2 > 1$$

$$0 < \beta_2 < 1$$

Multi-parametric strength degradation parameters must be:

$0 \leq \gamma_1 < 1$: If $\gamma_1 = 0$ no strength degradation will occur in the positive range (tension) and ϵ_1 , U_{mp} , δ_1 will be ignored

$0 \leq \gamma_2 < 1$: If $\gamma_2 = 0$ no strength degradation will occur in the negative range (compression) and ϵ_2 , U_{mp} , δ_2 will be ignored

$$\epsilon_1 \geq 0$$

$$\epsilon_2 \geq 0$$

$U_{mp} \geq 0$: If $U_{mp} = 0$ and $\gamma_1 > 0$ the U_{up} value will be used instead of U_{mp}

$U_{mn} \leq 0$: If $U_{mn} = 0$ and $\gamma_2 > 0$ the U_{un} value will be used instead of U_{mn}

$$\delta_1 \geq 0$$

$$\delta_2 \geq 0.$$

References

[1] Park, Y. J., Reinhorn, A. M., and Kunnath, S. K. (1987), IDARC: Inelastic damage analysis of reinforced concrete frame—shear-wall structures. Tech. Rep. NCEER-87-0008, State University of New York at Buffalo, Buffalo, N.Y.

[2] R. K. Dowell, F. S. Seible, and E. L. Wilson, (1998), Pivot Hysteretic Model for Reinforced Concrete Members, ACI Structural Journal, Vol. 95, pp. 607–617.

Formulation

Multi-Parametric Strength Degradation

$$\Delta F = F_y \cdot \gamma \cdot \left[1 - \left(1 - \left(\frac{E_p}{E_{um} + E_p} \right)^\epsilon \right) \cdot \left(1 - \left(\frac{u_{max}}{\Delta_{um}} \right)^\delta \right) \right]$$

where:

F_y = Yielding force

γ = 1st strength degradation parameter ($0 < \gamma < 1$)

E_p = Dissipated energy

E_{um} = Dissipated Energy in a Monotonic Loading

U_{max} = Maximim displacement

Δ_{um} = Ultimate Displacement in a Monotonic Loading

ϵ = 2nd Strength degradation parameter

δ = 3rd Strength degradation parameter.

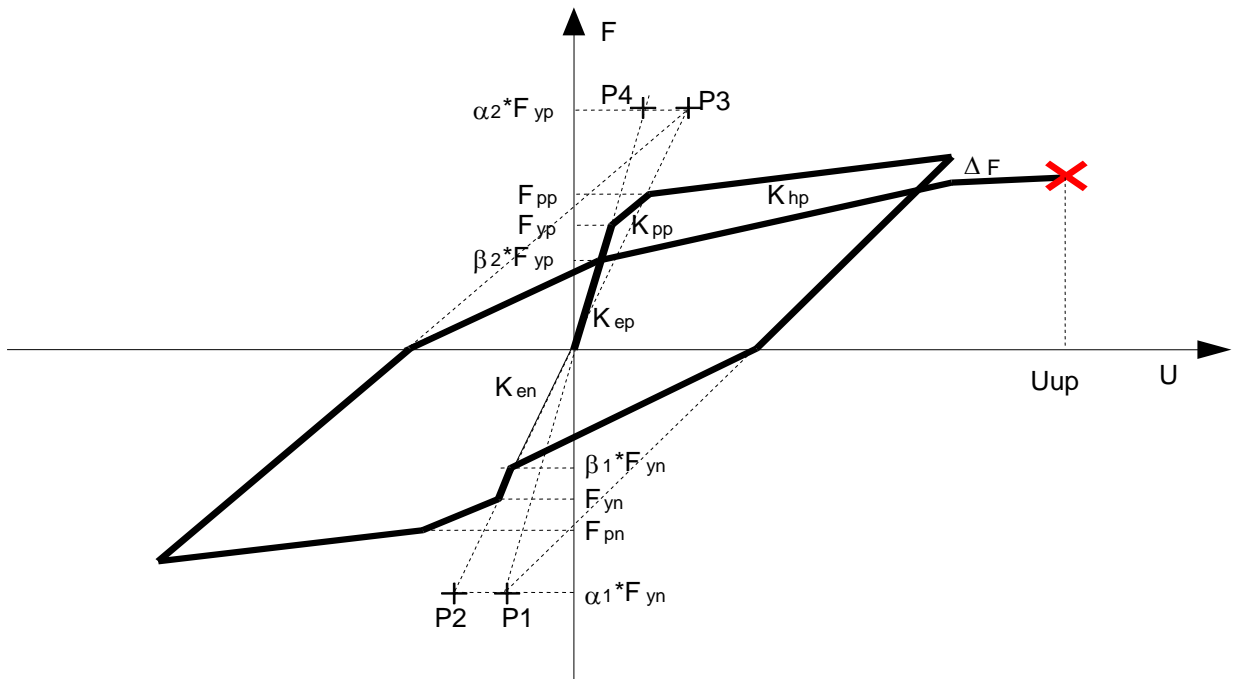

Force-displacement curve pivot

Description	Masonry decoupled pivot model for the equivalent frame modelling of 2D masonry walls.
Parameters	<p>Specified in this order:</p> <p>Ke = Stiffness of the elastic branch</p> <p>Fy/Vr = Ratio between the yielding force (or moment) and the shear (or bending) resistance Vr (or Mr)</p> <p>Kp = Stiffness of the 1st post elastic branch</p> <p>Fp/Vr = Ratio between the force (or moment) at the end of the first post elastic branch and the shear (or bending) resistance Vr (or Mr)</p> <p>Kh = Stiffness of the 2nd post elastic branch</p> <p>Ud = Ultimate displacement (or rotation)</p> <p>α = Pivot parameter (α>1)</p> <p>β = Pivot parameter (1>β>0)</p> <p>γ = Strength degradation parameter (0 ≤ γ < 1)</p> <p>δ = Strength degradation parameter (displacement)</p> <p>ε = Strength degradation parameter (energy)</p> <p>Um = Ultimate monotonic displacement</p> <p>Ener = Ultimate monotonic dissipated energy</p> <p>Vrmin = Minimum shear (or bending) resistance</p> <p>c = Coulomb's mortar cohesion</p> <p>μ = Coulomb's tangent of the friction angle of the mortar</p> <p>FBT = Ultimate traction stress of the bricks</p> <p>D = Wall width</p> <p>T = Wall thickness</p> <p>Fu = Ultimate compression stress of the masonry</p> <p>K = Stress distribution factor</p> <p>Ftu = Ultimate traction stress of the masonry</p> <p>b = Turnsek's shape parameter b=1.5 if H/D > 1.5, b=1 if H/D < 1 or b=H/D if 1 < H/D < 1.5</p> <p>cod= strength criteria code</p>
Characteristics	<p>Polygonal Hysteretic model based on the "Pivot Rule" proposed by Park and modified to prevent stiffness increase in decreasing load cycles and using multi-parametric strength degradation.</p> <p>This model also uses a combination of simplified strength criteria to determine the shear (or bending) resistance Vr.</p>
Formulation	<p>Multi-Parametric Strength Degradation:</p> $\Delta F = F_y \cdot \gamma \cdot \left[1 - \left(1 - \left(\frac{E_p}{E_{um} + E_p} \right)^\varepsilon \right) \cdot \left(1 - \left(\frac{u_{max}}{\Delta_{um}} \right)^\delta \right) \right]$ <p>where:</p> <p>Fy = Yielding force</p>

$\gamma = 1^{\text{st}}$ strength degradation parameter ($0 < \gamma < 1$)
 E_p = Dissipated energy
 E_{um} = Dissipated Energy in a Monotonic Loading
 U_{max} = Maximim displacement
 Δu_m = Ultimate Displacement in a Monotonic Loading
 $\varepsilon = 2^{\text{nd}}$ Strength degradation parameter
 $\delta = 3^{\text{rd}}$ Strength degradation parameter.

Failure due to diagonal cracking of the mortar layers:

$$V_{rd1} = D \cdot t \cdot \left(\frac{c + \mu \frac{N}{D \cdot t}}{1 + \frac{M}{V \cdot D}} \right)$$

Failure due to diagonal cracking of the bricks:

$$V_{rd2} = D \cdot t \cdot \frac{f_{bt}}{2.3 \cdot \left(1 + \frac{M}{V \cdot D} \right)} \cdot \sqrt{1 + \frac{N}{D \cdot t \cdot f_{bt}}}$$

Failure due to base shear distortion:

$$V_{rd3} = D \cdot t \cdot \left(\frac{1.5 \cdot c + \mu \cdot \frac{N}{D \cdot t}}{1 + 3 \cdot c \cdot \frac{\frac{M}{V \cdot D}}{\frac{N}{D \cdot t}}} \right)$$

Failure due to bending:

$$V_{rd4} = \frac{M_{ru4}}{H_0} = \frac{N \cdot D}{H_0 \cdot 2} \left(1 - \frac{N}{k \cdot f_u \cdot D \cdot t} \right) = \frac{N}{2 \cdot \frac{M}{V \cdot D}} \left(1 - \frac{N}{k \cdot f_u \cdot D \cdot t} \right)$$

Failure due to diagonal cracking accordingly to Turnsek and Cacovic criteria:

$$V_{rd5} = D \cdot t \cdot \frac{f_{tu}}{b} \cdot \sqrt{1 + \frac{N}{D \cdot t \cdot f_{tu}}}$$

Failure due to pure shear:

$$V_{rd6} = D \cdot t \cdot c$$

where:

$H_0 = M/V$ is the distance of the null point in the bending moment diagram from the section that we are looking at (see figure)

D = width of the wall

t is the thickness of the wall

N = axial force

V = shear force

M = bending moment

c, e, μ = parameters that define the strength of the mortar in the Coulomb's model

f_{bt} = ultimate traction stress of the bricks

f_u = ultimate compression stress of the masonry

k = parameter that defines the ratio between the pressure in an equivalent stress distribution and the maximum pressure in the compression zone (usually k=0.9, see figure)

f_{tu} = ultimate tensile stress of the masonry

b = Turnsek's shape parameter: b=1.5 if H/D >1.5 or b=1 if H/D <1 or b=H/D if 1 < H/D < 1.5

The shear strength will be computed as follows:

$$V_{rd} = \max(V_{r\min}; \min(V_{rd1}; V_{rd2}; V_{rd3}; V_{rd4}; V_{rd5}; V_{rd6}))$$

By means of the strength criteria code (cod) it is possible to specify which strength criteria account for and which strength criteria has to be neglected.

cod is defined as the sum of the exclusion code associated with the strength criteria to neglect:

<i>Exc. Code</i>		<i>Strength criteria</i>
1	Vrd1	Failure due to diagonal cracking of the mortar layers
2	Vrd2	Failure due to diagonal cracking of the bricks
4	Vrd3	Failure due to base shear distortion
8	Vrd4	Failure due to bending
16	Vrd5	Failure due to diagonal cracking accordingly to Turnsek and Cacovic criteria
32	Vrd6	Failure due to pure shear

For instance to exclude the Failure criteria due to pure shear and the Failure criteria due to diagonal cracking of the bricks, cod has to be defined as cod=32+2=34 and V_{rd} will be obtained as follows:

$$V_{rd} = \max(V_{r\min}; \min(V_{rd1}; V_{rd3}; V_{rd4}; V_{rd5}))$$

If the exclusion code is set to 63 (cod=63) then all strength criteria will be neglected and $V_{rd} = V_{r\min}$

Note: to compute the shear strength the model uses the values of the section forces N, V and M at the start of the integration step so to obtain an accurate response the integration step has to be small enough.

Application

Modelling of non linear behaviour of 2D masonry walls in the equivalent frame approach.

Restrictions

All parameters must be non negative

All stiffness parameters must be positive (>0)

$$0 < K_h < K_p < K_e$$

Force ratios and displacement must be positive (>0)

$$F_p/V_r > F_y/V_r > 0$$

$$U_d > 0$$

Pivot rule parameters must be:

$$\alpha > 1$$

$$0 < \beta < 1$$

Multi-parametric strength degradation parameters must be:

$$0 \leq \gamma < 1$$

If $\gamma=0$ no strength degradation will occur and ϵ , U_m , δ will be ignored

$$U_m \geq 0$$

If $U_m=0$ and $\gamma > 0$ the U_d value will be used instead of U_m

$$\delta \geq 0$$

$$\epsilon \geq 0$$

Turnsek's shape parameter

$$1.5 \geq b \geq 1.0$$

Exclusion code has to be an integer

$$63 \geq \text{cod} \geq 0$$

References

Pivot rule initially proposed in:

[1] Park, Y. J., Reinhorn, A. M., and Kunnath, S. K. (1987), IDARC: Inelastic damage analysis of reinforced concrete frame—shear-wall structures. Tech. Rep. NCEER-87-0008, State University of New York at Buffalo, Buffalo, N.Y.

Further development of the Pivot hysteretic model can be found in:

[2] R. K. Dowell, F. S. Seible, and E. L. Wilson, (1998), Pivot Hysteretic Model for Reinforced Concrete Members, ACI Structural Journal, Vol. 95, pp. 607–617.

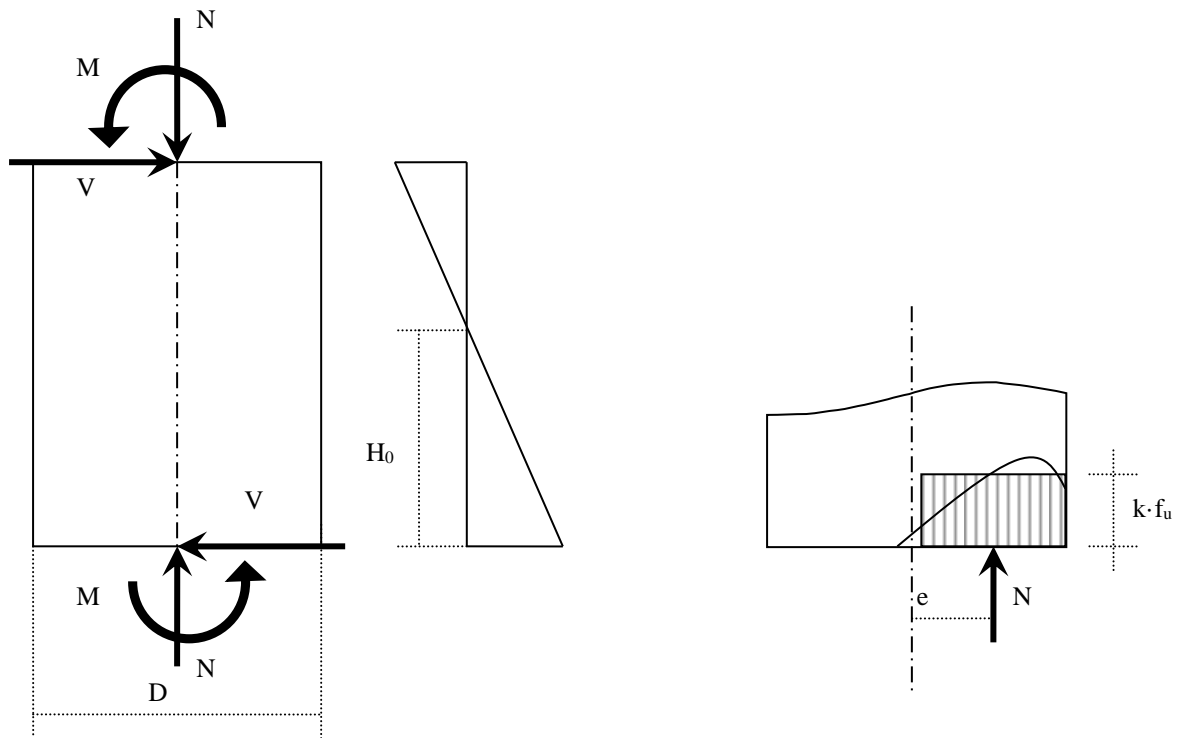

Mechanical model for curve masonry

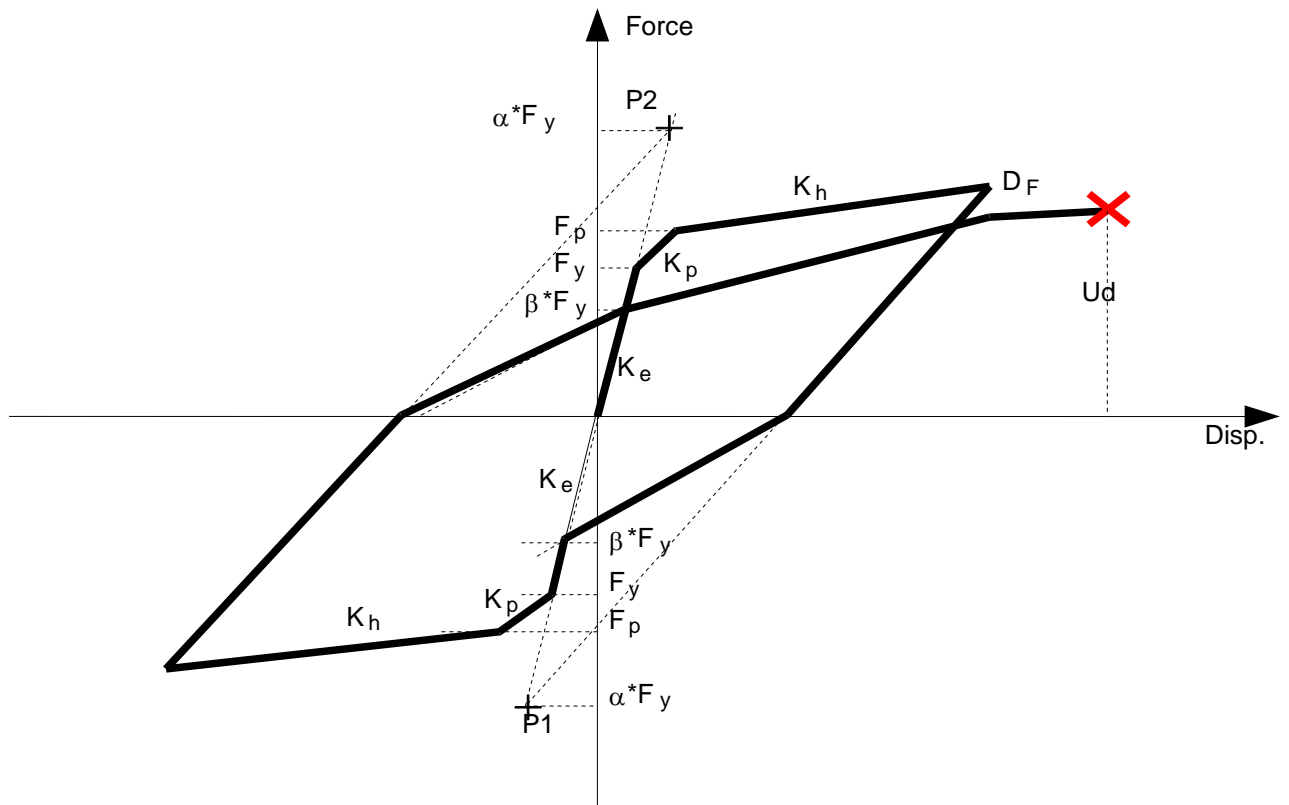

Force-displacement curve masonry

Description	Masonry decoupled S-shaped model for the equivalent frame modeling of 2D masonry walls.
Parameters	<p>Specified in this order:</p> <p>Ke = Stiffness of the elastic branch</p> <p>Fy/Vr = Ratio between the yielding force (or moment) and the shear (or bending) resistance Vr (or Mr)</p> <p>Kp = Stiffness of the 1st post elastic branch</p> <p>Fp/Vr = Ratio between the force (or moment) at the end of the first post elastic branch and the shear (or bending) resistance Vr (or Mr)</p> <p>CC=Parameter governing parallelism of branch 5 (or 50 - see img.) to branch 2 (or 20)</p> <p>CF=Parameter governing unloading from skeleton curve</p> <p>α= Parameter governing stiffness degradation (<1)</p> <p>CD=Parameter governing stiffness change after branch 5 (or 50)</p> <p>du=Ultimate displacement (or rotation)</p> <p>Pmin= Axial compression in masonry strips</p> <p>type= Pier (1) or strip (0)</p> <p>Fvk0= Pure shear strength</p> <p>B=Base width of the panel</p> <p>T=Thickness of the panel</p> <p>Fm=Compressive strength of masonry material</p> <p>H=Height of the panel</p> <p>Ftu=Tensile strength of masonry material</p> <p>Free parameter=used for compatibility with masonry tom model</p> <p>UltForce=No residual force after collapse (0) – Residual force after collapse (1)</p> <p>Upar=parameter dividing the stiffness of first unloading branch</p> <p>UltDisp= Calculate automatically ultimate displacement (0) – Fixed ultimate displacement from input (1)</p> <p>Rs=Residual strength</p>
Characteristics	<p>Polygonal hysteretic model based on the S-shaped law deduced from literature.</p> <p>This model also uses a combination of simplified strength criteria to determine the shear (or bending) resistance Vr.</p>
Formulation	<p>Stiffness Degradation: linear with the displacement, it depends on factor CK</p>

$$C_K = \frac{\frac{K_u}{K_e} - 1}{\frac{d_u}{d_{cr}} - 1}$$

where:

K_u =Ultimate stiffness

K_e =Elastic stiffness

d_u =Ultimate displacement

d_{cr} =Displacement at elastic limit

The unloading stiffness at a given displacement is calculated with:

$$K_d = K_e \left[1 + C_K \left(\frac{d_{\max}}{d_{cr}} - 1 \right) \right]$$

where:

d_{\max} = maximum displacement reached

K_d = Unloading stiffness

Strength criteria: The model can use any combination of the following simplified strength criteria to determine the shear (or bending) resistance V_r (or M_r).

Failure due to rocking:

$$V_1 = \frac{b}{h_0} \frac{N}{2} \left(1 - \frac{N}{0.85b \cdot t \cdot f_m} \right)$$

Failure due to sliding:

$$V_2 = \frac{1.5b \cdot t \cdot f_{vk0} + 0.4N}{1 + \frac{3h_0 \cdot t \cdot f_{vk0}}{N}}$$

Failure due to diagonal cracking according to Turnsek-Cacovic criteria:

$$V_3 = \frac{1.5f_{td} \cdot b \cdot t}{\xi} \sqrt{1 + \frac{N}{f_{td} \cdot b \cdot t}}$$

Failure due to pure shear:

$$V_4 = f_{vk0} \cdot B \cdot T$$

Failure due to rocking in strips:

$$V_5 = \frac{h}{b} P_{\min} \left(1 - \frac{P_{\min}}{0.85b \cdot t \cdot f_m} \right)$$

where:

$h_0 = M/V$ is the distance of the null point in the bending moment diagram from the section that we are looking at

h is the height of the wall

b is the width of the wall
 t is the thickness of the wall
 N is the axial force
 V is the shear force
 M is the bending moment
 f_{vk0} is the pure shear strength
 f_{tu} is the ultimate tensile stress of the masonry
 f_m is the ultimate compression stress of the masonry
 χ is Turnsek's shape parameter (=1.5 if $H/D > 1.5$ or =1 if $H/D < 1$ or = H/D otherwise)

The shear strength will be computed as follows:

$$V_{rd} = \min(V_{rd1}; V_{rd2}; V_{rd3})$$

For strips the strength is the pure shear strength for the shear force, and the rocking strength (calculated on P_{min}) for bending moment.

Note: to compute the shear strength the model uses the values of the section forces N, V and M at the start of the integration step so to obtain an accurate response the integration step has to be small enough.

Application

Modelling of non linear behaviour of 2D masonry walls in the equivalent frame approach.

Restrictions

All parameters must be non negative.

All stiffness parameters must be positive (>0)

$$0 < K_p < K_e$$

Force ratios and displacement must be positive (>0)

$$F_p/V_r > F_y/V_r > 0$$

$$d_u > 0$$

Degradations parameters must be:

$$\alpha < 1$$

$$\beta < 1$$

and $U_{par} \geq 1$

References

Rinaldin, G.

“Seismic analysis of masonry structures through non-linear analysis”

Graduation Thesis, supervisor Prof. Ing. C. Amadio, University of Trieste 2009 (in Italian)

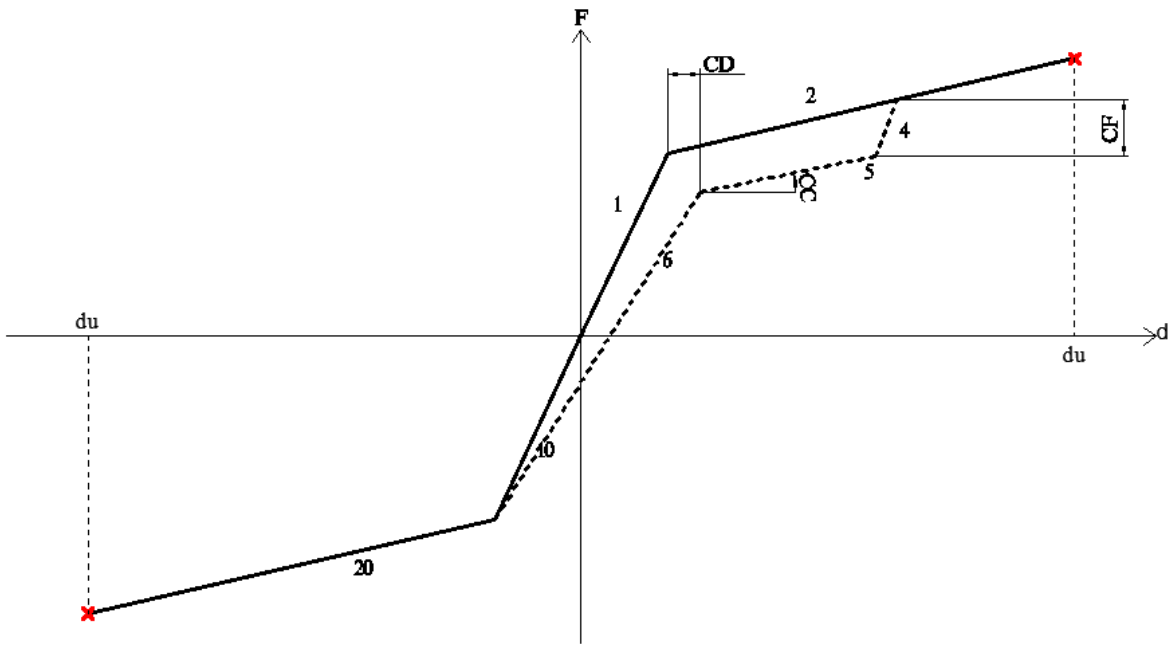

Force-displacement curve ssh

Description	Masonry decoupled Tomazevic's model for the equivalent frame modeling of 2D masonry walls.
Parameters	<p>Specified in this order:</p> <p>Ke = Stiffness of the elastic branch</p> <p>Fy/Vr = Ratio between the yielding force (or moment) and the shear (or bending) resistance Vr (or Mr)</p> <p>Kp = Stiffness of the 1st post elastic branch</p> <p>Fp/Vr = Ratio between the force (or moment) at the end of the first post elastic branch and the shear (or bending) resistance Vr (or Mr)</p> <p>Kh=Stiffness of the 2nd post elastic branch</p> <p>CF=Parameter governing unloading from skeleton curve</p> <p>α= Parameter governing stiffness degradation (<1)</p> <p>β= Parameter governing strength degradation (<1)</p> <p>du=Ultimate displacement (or rotation)</p> <p>Pmin= Axial compression in masonry strips</p> <p>type= Pier (1) or strip (0)</p> <p>Fvk0= Pure shear strength</p> <p>B=Base width of the panel</p> <p>T=Thickness of the panel</p> <p>Fm=Compressive strength of masonry material</p> <p>H=Height of the panel</p> <p>Ftu=Tensile strength of masonry material</p> <p>UF%=percentage of the maximum force after which panel collapse, used to calculate ultimate displacement automatically</p> <p>UltForce=No residual force after collapse (0) – Residual force after collapse (1)</p> <p>Upar=parameter dividing the stiffness of first unloading branch</p> <p>UltDisp= Calculate automatically ultimate displacement (0) – Fixed ultimate displacement from input (1)</p> <p>Rs=Residual strength</p>
Characteristics	<p>Polygonal hysteretic model based on the Tomazevic's proposal (1996).</p> <p>This model also uses a combination of simplified strength criteria to determine the shear (or bending) resistance Vr.</p>
Formulation	<p>Stiffness Degradation: linear with the displacement, it depends on factor CK</p> $C_K = \frac{\frac{K_u}{K_e} - 1}{\frac{d_u}{d_{cr}} - 1}$ <p>where:</p> <p>Ku =Ultimate stiffness</p>

K_e =Elastic stiffness
 d_u =Ultimate displacement
 d_{cr} =Displacement at elastic limit

The unloading stiffness at a given displacement is calculated with:

$$K_d = K_e \left[1 + C_K \left(\frac{d_{\max}}{d_{cr}} - 1 \right) \right]$$

where:

d_{\max} = maximum displacement reached
 K_d = Unloading stiffness

Strength Degradation: it is taken into account by considering an additional displacement related to the arrival in the skeleton curve inelastic branches.

$$\delta d^+ = \beta \left(\frac{dE^+}{H_{\max}} \right)$$

or, for negative increments:

$$\delta d^- = \beta \left(\frac{dE^-}{H_{\max}} \right)$$

where:

dE^{\pm} = dissipated energy in a cycle
 H_{\max} = maximum force reached by the skeleton curve
 β = strength degradation parameter
 δd^{\pm} = displacement increment

Strength criteria: The model can use any combination of the following simplified strength criteria to determine the shear (or bending) resistance V_r (or M_r).

Failure due to rocking:

$$V_1 = \frac{b}{h_0} \frac{N}{2} \left(1 - \frac{N}{0.85b \cdot t \cdot f_m} \right)$$

Failure due to sliding:

$$V_2 = \frac{1.5b \cdot t \cdot f_{vk0} + 0.4N}{1 + \frac{3h_0 \cdot t \cdot f_{vk0}}{N}}$$

Failure due to diagonal cracking according to Turnsek-Cacovic criteria:

$$V_3 = \frac{1.5f_{td} \cdot b \cdot t}{\xi} \sqrt{1 + \frac{N}{f_{td} \cdot b \cdot t}}$$

Failure due to pure shear:

$$V_4 = f_{vk0} \cdot B \cdot T$$

Failure due to rocking in strips:

$$V_5 = \frac{h}{b} P_{\min} \left(1 - \frac{P_{\min}}{0.85b \cdot t \cdot f_m} \right)$$

where:

$h_0 = M/V$ is the distance of the null point in the bending moment diagram from the section that we are looking at

h is the height of the wall

b is the width of the wall

t is the thickness of the wall

N is the axial force

V is the shear force

M is the bending moment

f_{vk0} is the pure shear strength

f_{tu} is the ultimate tensile stress of the masonry

f_m is the ultimate compression stress of the masonry

χ is Turnsek's shape parameter (=1.5 if $H/D > 1.5$ or =1 if $H/D < 1$ or = H/D otherwise)

The shear strength will be computed as follows:

$$V_{rd} = \min(V_{rd1}; V_{rd2}; V_{rd3})$$

For strips the strength is the pure shear strength for the shear force, and the rocking strength (calculated on P_{\min}) for bending moment.

Note: to compute the shear strength the model uses the values of the section forces N, V and M at the start of the integration step so to obtain an accurate response the integration step has to be small enough.

Application

Modelling of non linear behaviour of 2D masonry walls in the equivalent frame approach.

Restrictions

All parameters must be non negative.

All stiffness parameters must be positive (>0)

$$0 < K_h < K_p < K_e$$

Force ratios and displacement must be positive (>0)

$$F_p/V_r > F_y/V_r > 0$$

$$du > 0$$

Degradations parameters must be:

$$\alpha < 1$$

$$\beta < 1$$

and $U_{par} \geq 1$

References

Tomazevic, M., Lutman M. (1996)
“Seismic Behaviour of Masonry Walls: Modeling of Hysteretic Rules”
Journal of Structural Engineering, September 1996, pp.1048-1054

Rinaldin, G.
“Seismic analysis of masonry structures through non-linear analysis”
Graduation Thesis, supervisor Prof. Ing. C. Amadio,
University of Trieste 2009 (in Italian)

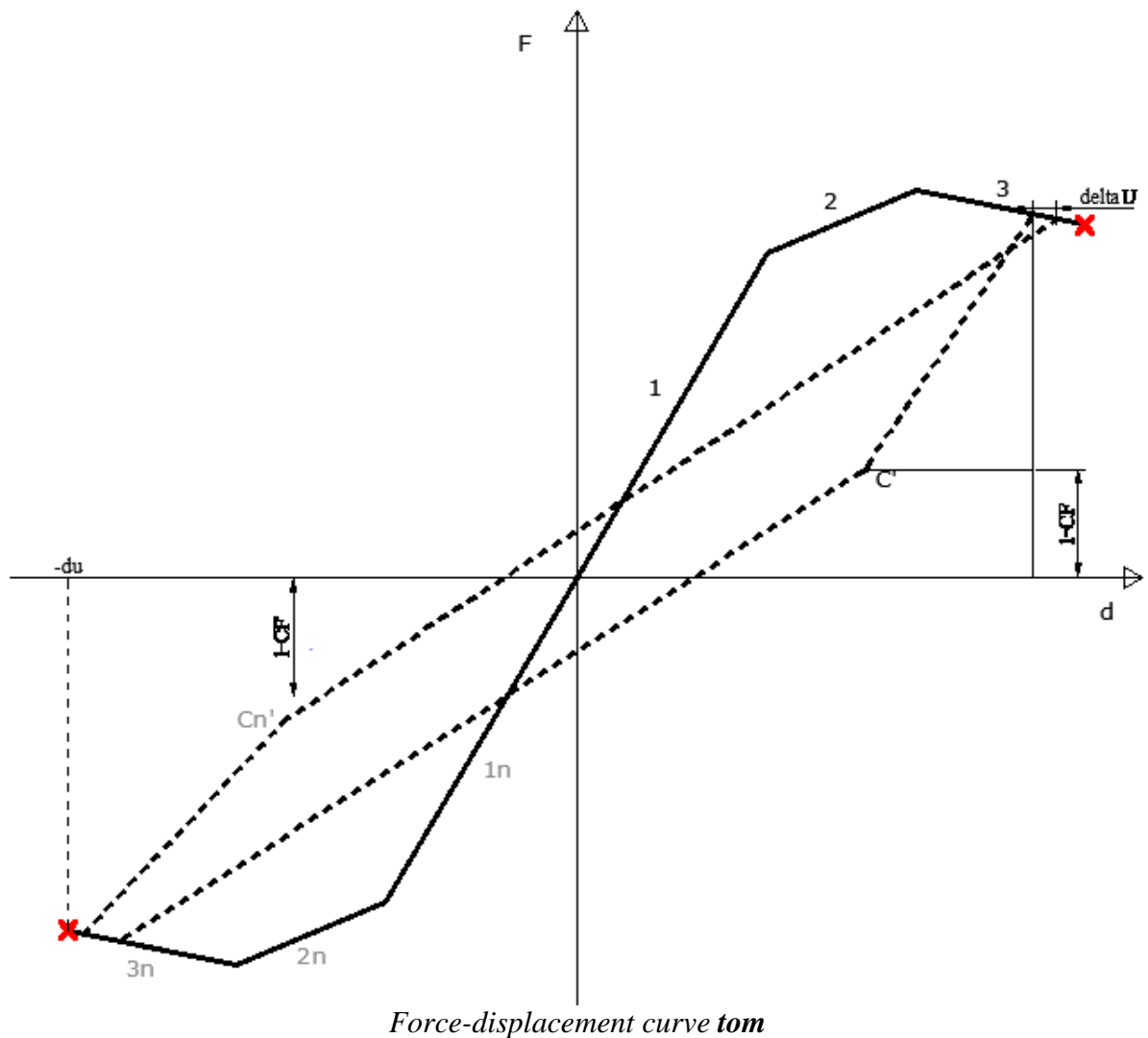

Chapter 5. CROSS-SECTION TYPES

The ADAPTIC library also includes a number of pre-defined cross-section types described briefly below:

<u>Type</u>	<u>Description</u>
<u>rss</u>	Rectangular solid section
<u>chs</u>	Circular hollow section
<u>isec</u>	General purpose I- or T-section
<u>pnci</u>	Partially encased composite I-section
<u>fnci</u>	Fully encased composite I-section
<u>rccs</u>	Reinforced concrete column section
<u>rects</u>	Reinforced concrete T-section
<u>flxw</u>	Reinforced concrete flexural wall section

The degree of accuracy in modelling the above sections depends on the formulation utilising the cross-section.

Cubic formulations ([cbp2](#), [cbp3](#)) provide detailed modelling of a cross-section through its discretisation into a number of areas where the uniaxial material response is monitored according to the previous material models.

Plastic-hinge formulations ([gph2](#), [gph3](#)) derive a plastic interaction surface between the cross-sectional bending moments and axial force, which is combined with the associated flow rule to provide approximate modelling of steel members. The plastic hinge capability is not extended to reinforced concrete sections.

Elastic formulations utilise constant elastic rigidities for bending, axial and torsional actions derived for given cross-sectional configurations. As such they are only accurate for steel members, since they do not account for concrete cracking.

This section describes the cross-section types available in ADAPTIC. Each type is referred to by a unique name, displayed at the top of the following pages, and requires the specification of a number of materials and dimensions in the order indicated.

rss

Description	Rectangular solid section.
No. of materials	1
No. of dimensions	2
Dimensions	Width (b) Depth (d)
Application	Rectangular solid sections of uniform material.

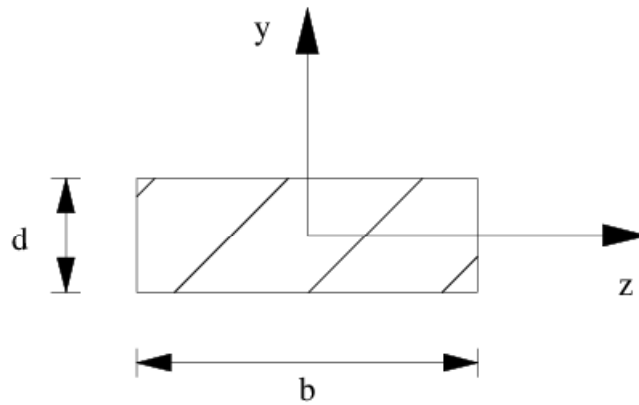

Section rss

chs

Description	Thin circular hollow section.
No. of materials	1
No. of dimensions	2
Dimensions	Outer diameter (D) Tube thickness (t)
Application	Circular hollow sections of uniform material.

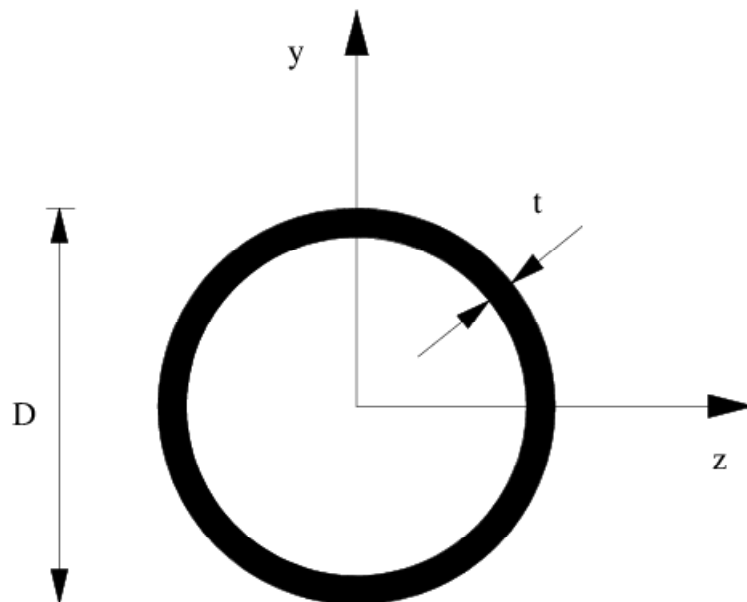

Section chs

isec

<i>Description</i>	General purpose I- or T-section.
<i>No. of materials</i>	1
<i>No. of dimensions</i>	6
<i>Dimensions</i>	Bottom flange width (b_{f1})
	Bottom flange thickness (t_{f1})
	Top flange width (b_{f2})
	Top flange thickness (t_{f2})
	Web depth (d_w)
	Web thickness (t_w)
<i>Application</i>	I- or T-sections of uniform material.

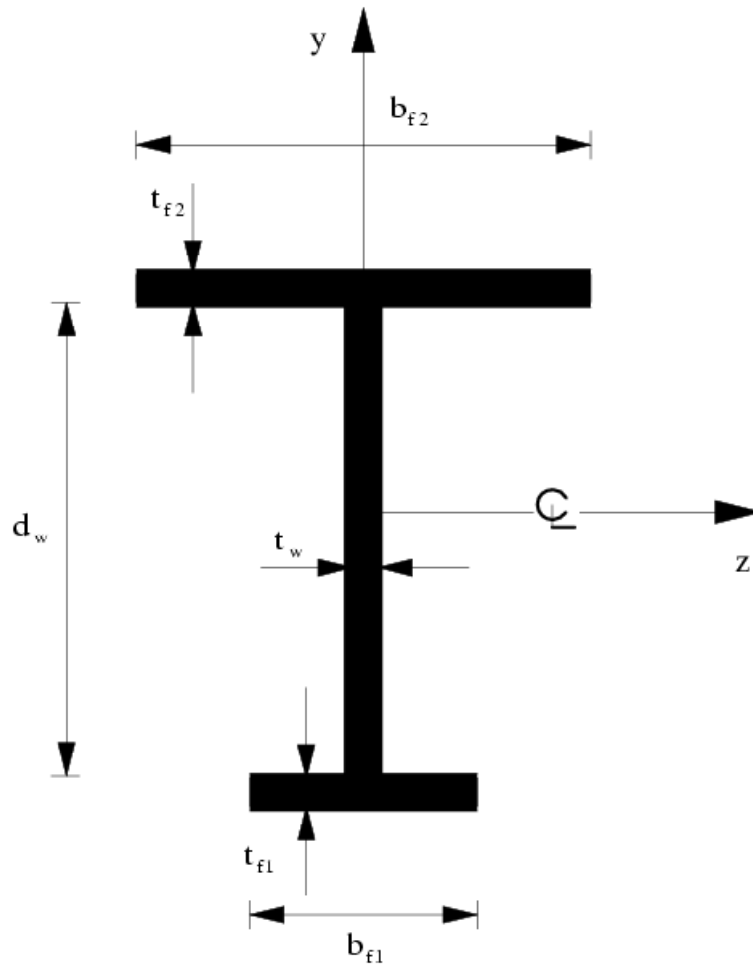

Section isec

Description	General purpose thin-walled open cross-section.	
No. of materials	1	
No. of dimensions	4×s, where s is the number of cross-section segments.	
Dimensions	For each segment (i) in order:	
	Width	(b_i)
	Thickness	(t_i)
	Angle in degrees	(θ_i)
	Number of forking segments at end	(n_i)
Application	Open thin-walled I-, T- or C-sections of uniform material.	

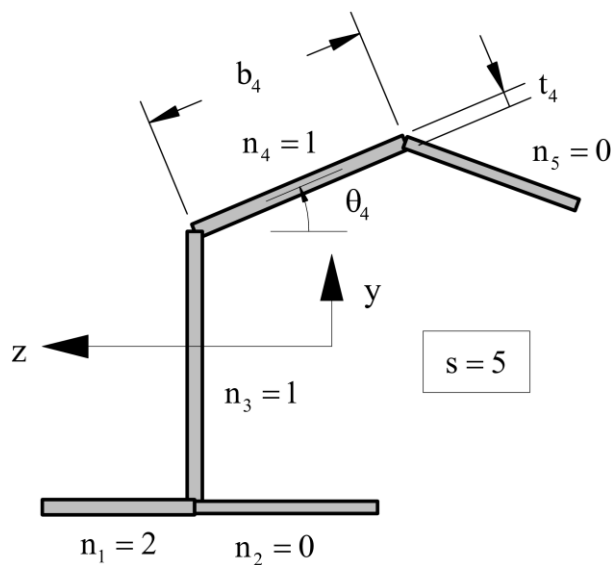

*Section **opt** (illustration for cross-section with 5 segments)*

Description	Partially encased composite I-section.	
No. of materials	4, specified in this order: I-section Unconfined region Partially confined region Fully confined region	
No. of dimensions	6	
Dimensions	Flange width	(b_f)
	Flange thickness	(t_f)
	Web depth	(d_w)
	Web thickness	(t_w)
	Unconfinement ratio	(r_{uc}) [*]
	Partial confinement ratio	(r_{pc}) [*]
Application	Partially encased composite I-sections, with three different concrete materials to represent confinement effects.	
	(*) $r_{uc} = 2 t_{uc} / (b_f - t_w)$ & $r_{pc} = 2 t_{pc} / (b_f - t_w)$, where t_{uc} and t_{pc} are the thickness of the unconfined and confined parts of the section, respectively.	

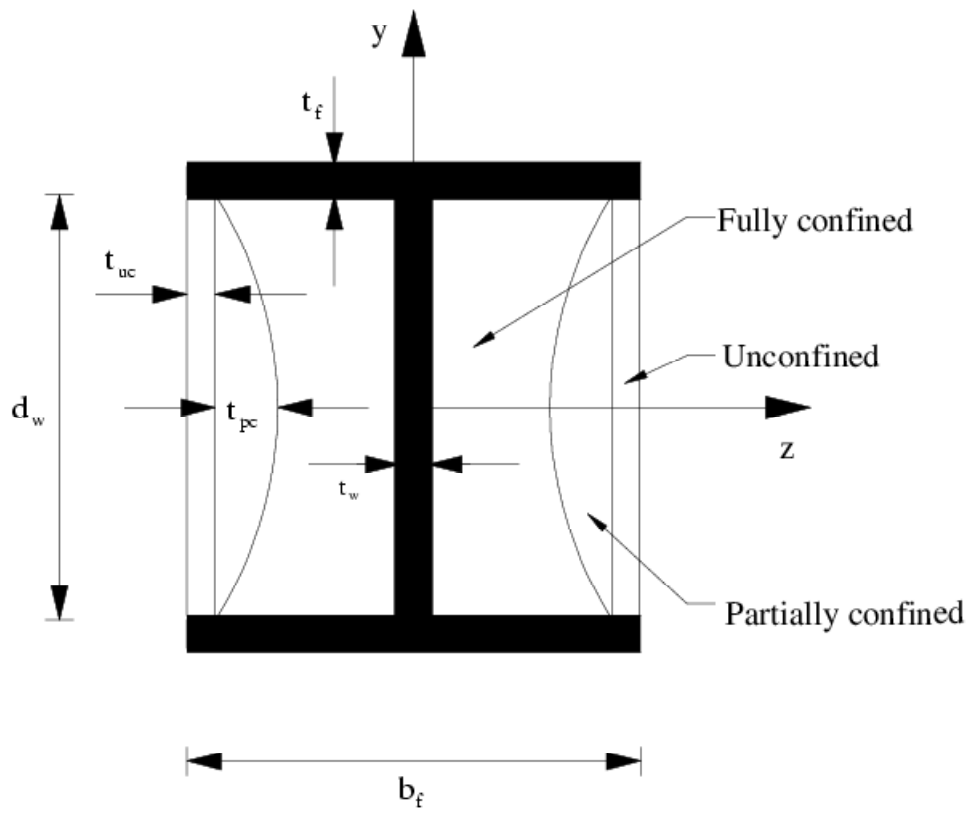

*Section **pnci***

Description	Fully-encased composite I-section.	
No. of materials	4, specified in this order: I-section Unconfined region Partially confined region Fully confined region	
No. of dimensions	9	
Dimensions	Flange width	(b_f)
	Flange thickness	(t_f)
	Web depth	(d_w)
	Web thickness	(t_w)
	Partial confinement ratio	(r_{pc})*
	Stirrup width	(b_{cl})
	Section width	(b_{c2})
	Stirrup depth	(h_{cl})
	Section depth	(h_{c2})
Application	Fully encased composite I-sections, with three different concrete materials to represent confinement effects.	
	(*) $r_{pc} = 2 t_{pc} / (b_f - t_w)$, where t_{pc} is the depth of the partially confined part beyond the section flange.	

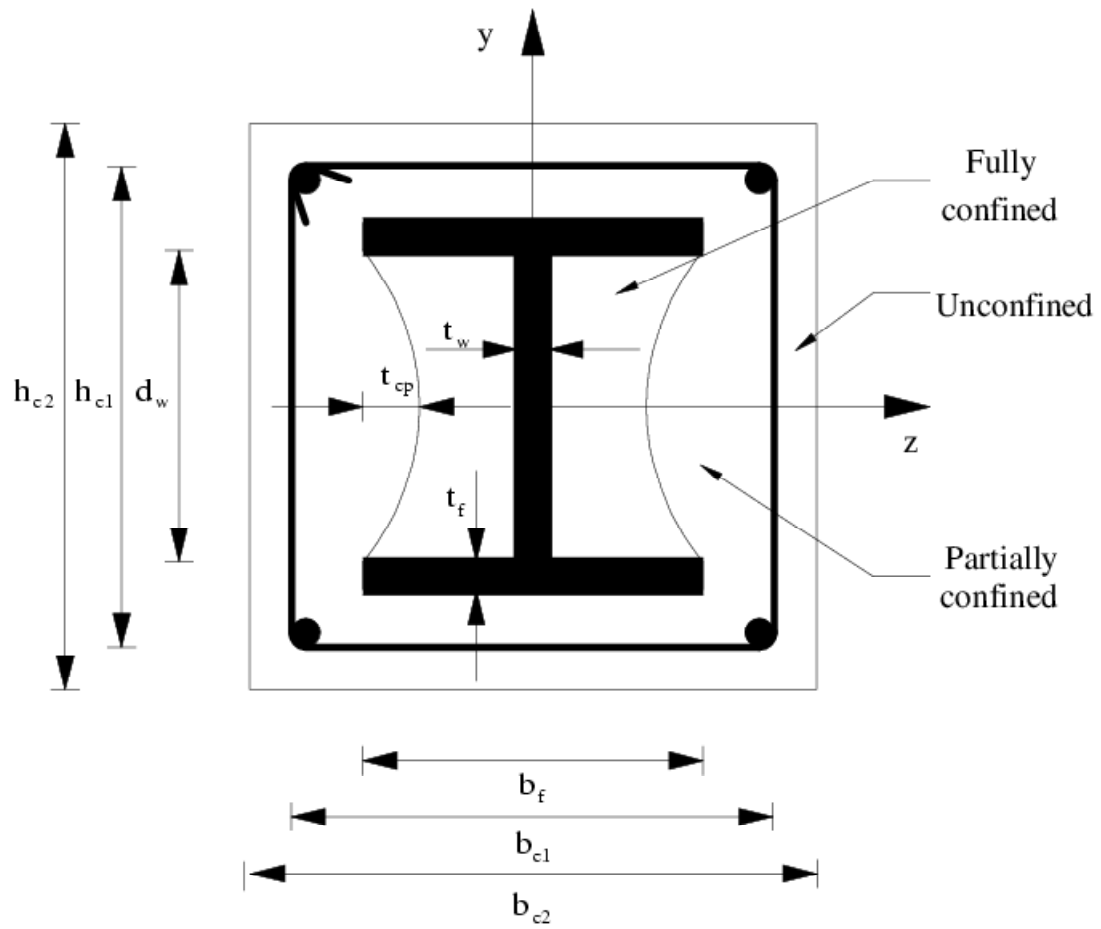

Section fnci

Description	Flexural wall section.
No. of materials	4, specified in this order: Reinforcement Unconfined region Partially confined region Fully confined region
No. of dimensions	2D analysis: $5 + 2$ (Reinforcement <u>layers</u> on one side of z-axis) 3D analysis: $5 + 3$ (Reinforcement <u>bars</u> in one y-z quadrant)
Dimensions	Wall width (B) Confined width (b) Wall thickness (T) Confined thickness (t) Depth of fully confined region (C) 2D analysis: (A_i, y_i) for each reinforcement <u>layer</u> on one side of the z-axis. 3D analysis: (A_i, y_i, z_i) for each reinforcement <u>bar</u> in the positive y-z quadrant.
Application	Symmetric flexural walls.
Restrictions	Section is assumed symmetric about the y-z origin, hence only one side of the reinforcement need to be specified.

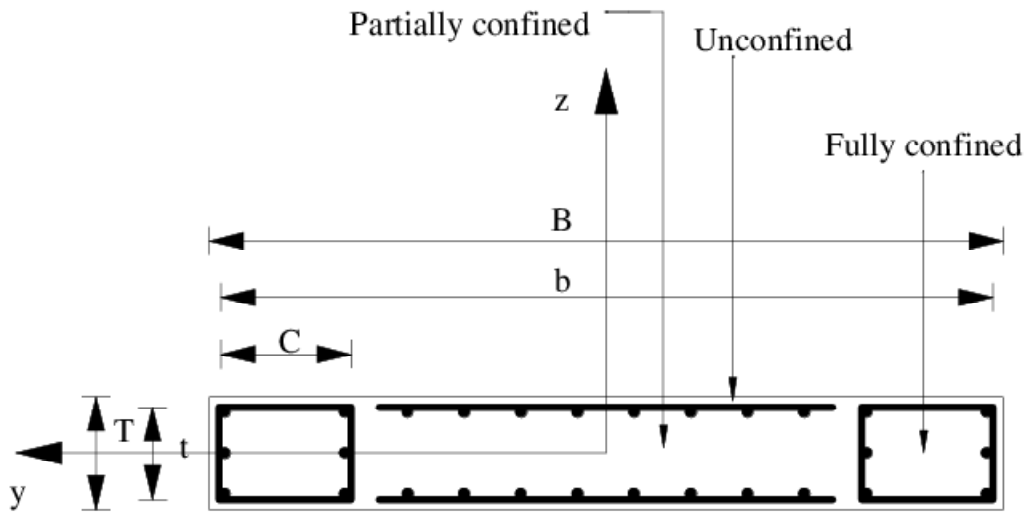

Section flxw

rccs

<i>Description</i>	Reinforced concrete column section.
<i>No. of materials</i>	3, specified in this order: Reinforcement Unconfined region Confined region
<i>No. of dimensions</i>	2D analysis: 4 + 2 (Reinforcement <u>layers</u> on one side of z-axis) 3D analysis: 4 + 3 (Reinforcement <u>bars</u> in one y-z quadrant)
<i>Dimensions</i>	Section depth (h_{c1}) Stirrup depth (h_{c2}) Section width (b_{c1}) Stirrup width (b_{c2}) 2D analysis: (A_i, y_i) for each reinforcement <u>layer</u> on one side of the z-axis. 3D analysis: (A_i, y_i, z_i) for each reinforcement <u>bar</u> in the positive y-z quadrant.
<i>Application</i>	Symmetric reinforced concrete columns.
<i>Restrictions</i>	Section is assumed symmetric about the y-z origin, hence only one side of the reinforcement need to be specified.

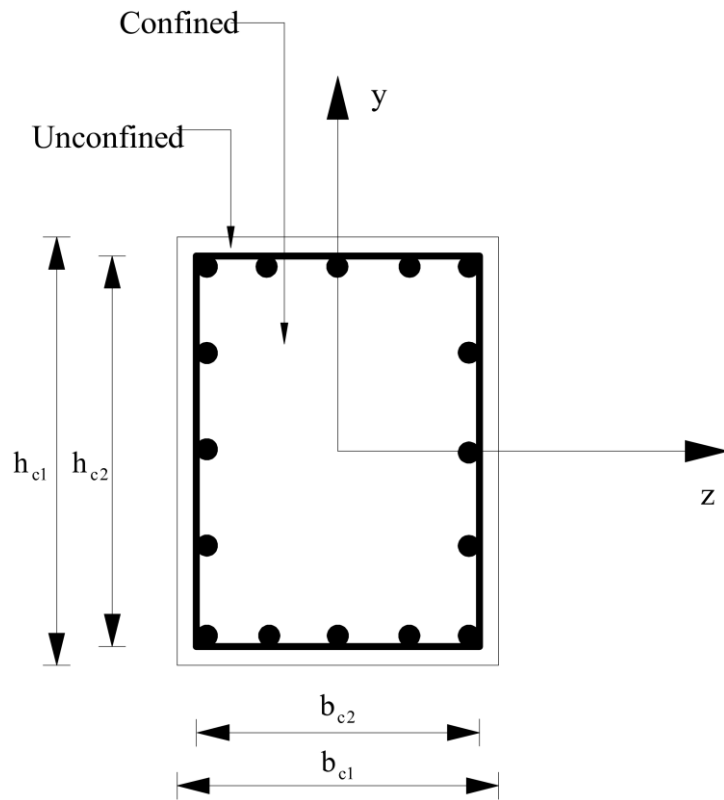

Section rccs

Description	Reinforced concrete T-section.
No. of materials	3, specified in this order: Reinforcement Unconfined region Confined region
No. of dimensions	2D analysis: 8 + 2 (Reinforcement <u>layers</u>) 3D analysis: 8 + 3 (Reinforcement <u>bars</u> on one side of y-axis)
Dimensions	Slab thickness (D_f) Beam depth (D_w) Confined depth in slab (d_f) Confined depth in beam (d_w) Slab effective width (B_f) Beam width (B_w) Confined width in slab (b_f) Confined width in beam (b_w) 2D analysis: (A_i, d_i^*) for each reinforcement <u>layer</u> . 3D analysis: (A_i, d_i^*, z_i) for each reinforcement <u>bar</u> on one side of the y-axis.
Application	Modelling of R/C beams with an effective slab width.
Restrictions	Symmetric section about the y-axis. (*) d_i is the distance of reinforcement layer/bar (i) from the bottom fibre of the section.

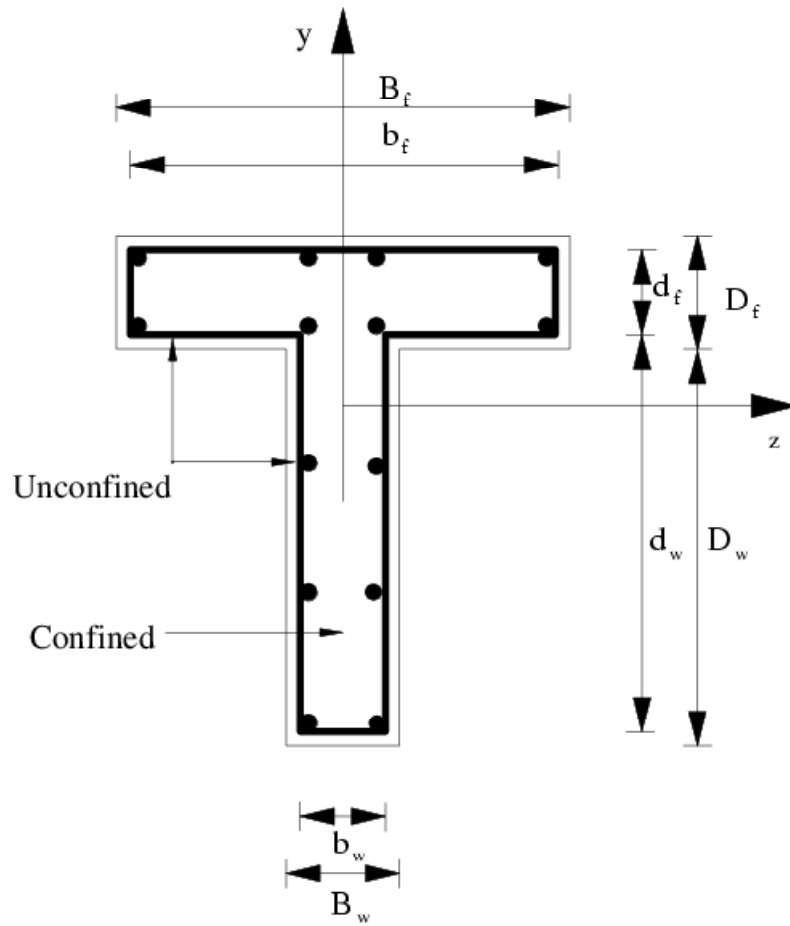

Section rcts

Description	General purpose reinforced concrete I- or T-section.
No. of materials	1
No. of dimensions	2D analysis: 6 + 2 (Reinforcement <u>layers</u>)
Dimensions	Bottom flange width (b_{f1}) Bottom flange thickness (t_{f1}) Top flange width (b_{f2}) Top flange thickness (t_{f2}) Web depth (d_w) Web thickness (t_w) 2D analysis: (A_i, d_i^*) for each reinforcement <u>layer</u> .
Application	General reinforced concrete I- or T-sections.
Restrictions	Symmetric section about the y-axis. (*) d_i is the distance of reinforcement layer/bar (i) from the bottom fibre of the section.

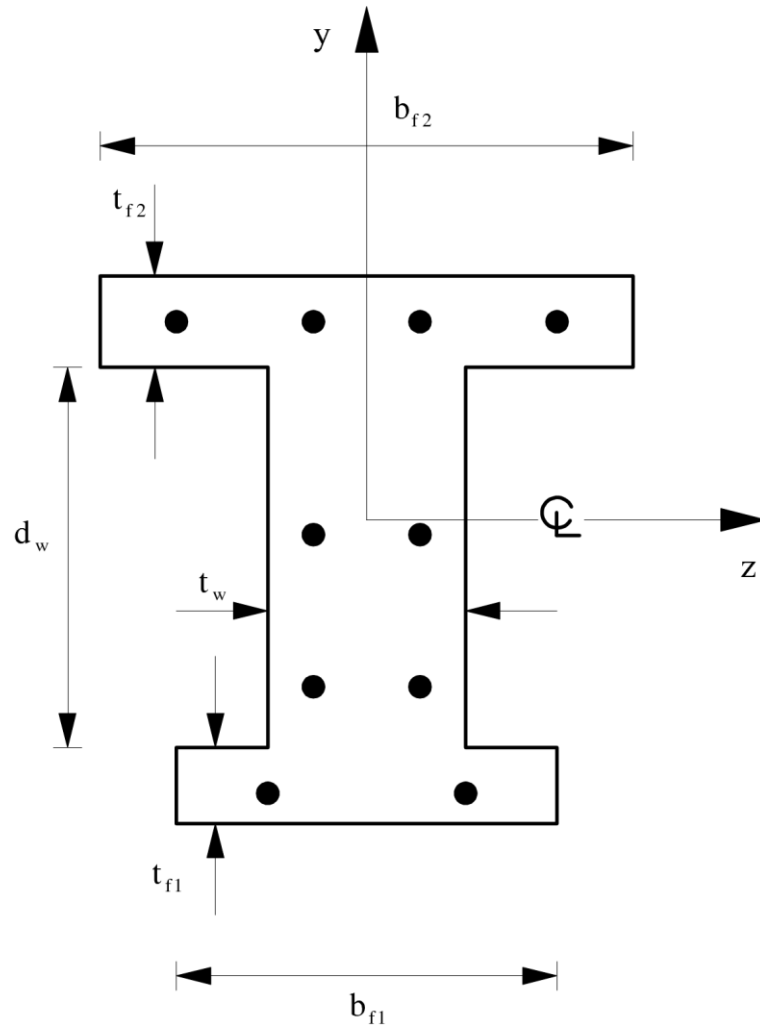

Section rcgs

<i>Description</i>	Composite floor slab section	
<i>No. of materials</i>	4 specified in this order:	
	Deck - horizontal	
	Deck – inclined on rib sides	
	Reinforcement	
	Concrete	
<i>No. of dimensions</i>	12	
<i>Dimensions</i>	Depth of cover:	(t)
	Depth of rib	(h)
	Rib geometric ratio	(r)
	Thickness of steel deck	(t _d)
	Reinforcement area per unit length in local x-direction	(t _x)
	Location of reinforcement in x-direction above (+)/below (-) reference mid-plane	(d _x)
	Reinforcement area per unit length in local y-direction	(t _y)
	Location of reinforcement in y-direction above (+)/below (-) reference mid-plane	(d _y)
	The remaining 4 dimensions are for two additional reinforcement layers in x and y-directions.	
<i>Application</i>	Composite floor slab cross-section consisting of ribbed reinforced concrete acting compositely with trapezoidal steel decking.	

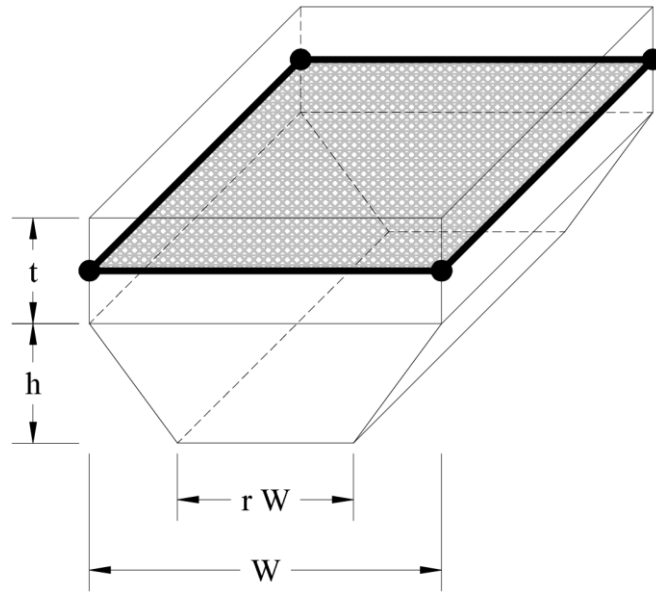

Section cs1b

thpl

<i>Description</i>	Thin plate section.
<i>No. of materials</i>	1
<i>No. of dimensions</i>	1
<i>Dimensions</i>	Plate thickness (t)
<i>Application</i>	Plate bending and membrane analysis.

Chapter 6. ELEMENT TYPES

This section describes the element types available in ADAPTIC. Each type is referred to by a unique name, displayed at the top of the following pages, and requires the specification of a number of entries for its groups, connectivity and other modules.

cbe2

Description	Cubic 2D elastic element with uncoupled bending and axial actions.
Nodes	2
Characteristics	Accounts for large nodal displacements, but requires a number of elements to represent a member with significant beam-column action.
Application	Elastic analysis of plane frames
Restrictions	Unable to model concrete cracking.
Group header	<code>sec.name</code> : An identifier referring to one of the cross-sections declared in the <code>sections</code> module.

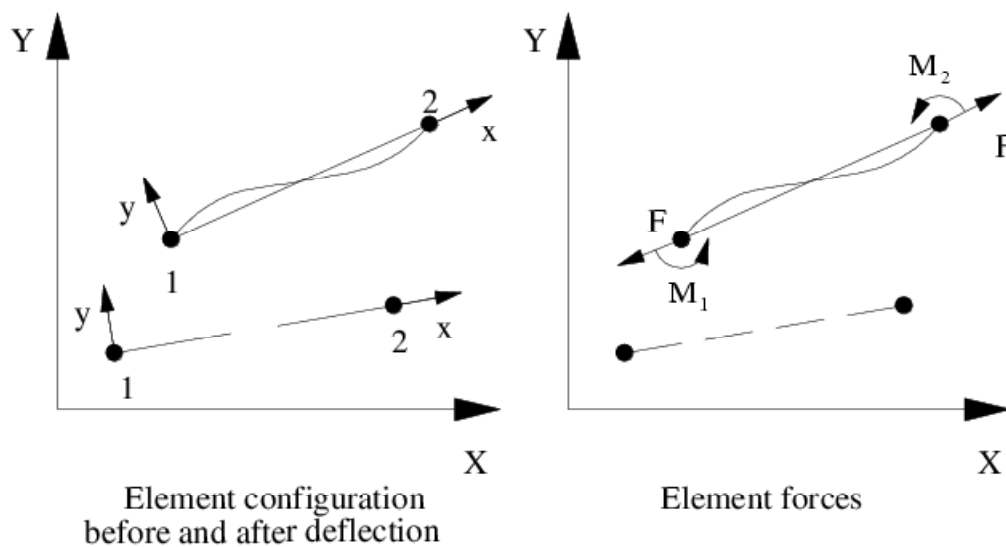

Configuration and forces in local system of element type cbe2

Description	Cubic elasto-plastic 2D beam-column element.
Monitoring points	25 points usually adequate; depends on section type.
Nodes	2
Characteristics	<p>Geometric and material nonlinearities.</p> <p>Numerical integration performed over two Gauss points.</p> <p>A number of monitoring areas used at each Gauss section to monitor material direct stress and strains.</p> <p>Predicts global member behaviour based on a material stress-strain relationship.</p> <p>A number of elements per member, usually over 5, must be used for reasonable accuracy in inelastic modelling.</p>
Application	Modelling of inelastic members in plane frames.
Restrictions	
Group header	<p>sec.name: An identifier referring to one of the cross-sections declared in the sections module.</p> <p>monitoring.points: Defines the number of points for monitoring stresses and strains within a cross-section.</p>

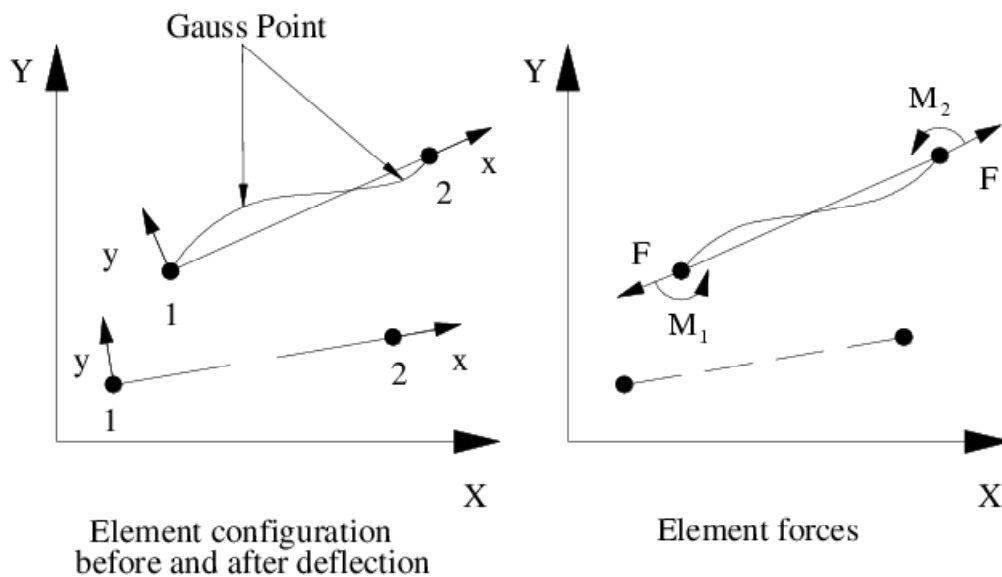

Configuration and forces in local system of element type *cbp2*

qel2

Description	Quartic elastic 2D beam-column element.
Nodes	2
Imperfections	$V_{0.25L}$, $V_{0.5L}$, $V_{0.75L}$ can be specified.
Characteristics	<p>Geometric nonlinearities. Large displacements and beam-column effect of perfect/imperfect members.</p> <p>One element type <i>qel2</i> is usually sufficient to represent the beam-column effect and large displacement response of a whole elastic member.</p>
Application	Geometric nonlinearities in elastic plane frames.
Restrictions	Unable to model concrete cracking.
Group header	sec.name : An identifier referring to one of the cross-sections declared in the sections module.

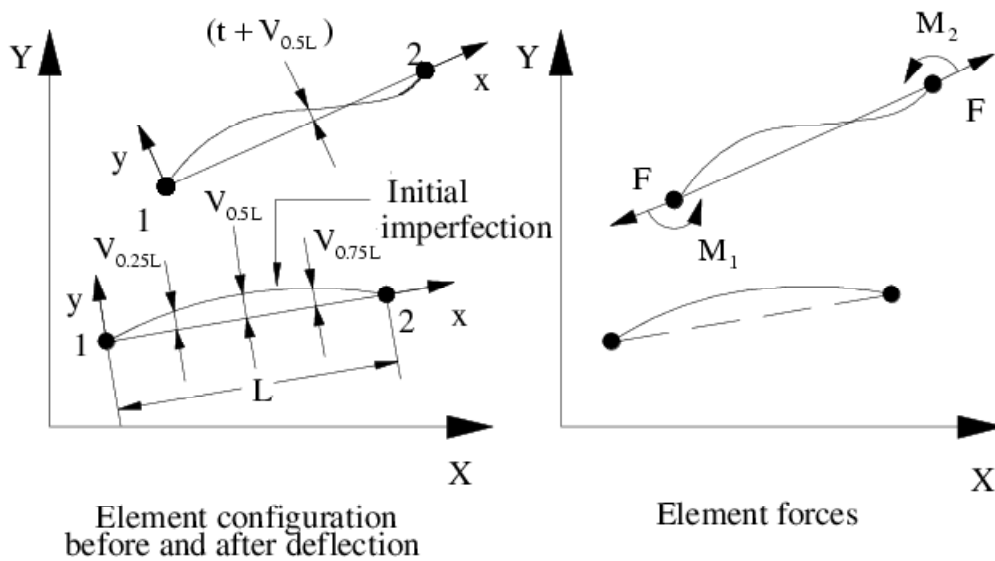

Configuration and forces in local system of element type *qel2*

qph2

Description	Quartic plastic hinge 2D beam-column element with an option for automatic subdivision.
Nodes	2
Subdivision	Automatic subdivision into two elements if a plastic hinge is detected within the element may be requested.
Imperfections	$V_{0.25L}$, $V_{0.5L}$, $V_{0.75L}$ can be specified.
Characteristics	<p>Geometric and material nonlinearities.</p> <p>Suitable for members in which the spread of plasticity is not important and the section response is elastic-plastic without strain-hardening.</p> <p>Rotational and axial plastic hinge displacements are allowed at the two ends of the element.</p> <p>One element type <i>qph2</i> is usually sufficient to model a whole member, and the option of subdivision allows for the case of member buckling.</p>
Application	Large displacement plastic-hinge analysis of plane frames
Restrictions	Not applicable to reinforced concrete or composite members.
Group header	<p>sec.name: An identifier referring to one of the cross-sections declared in the sections module.</p> <p>subdivision: Gives the option for automatic subdivision plastic hinge elements:</p> <p>=(t true) consider element subdivision</p> <p>=(f false) ignore element subdivision</p>

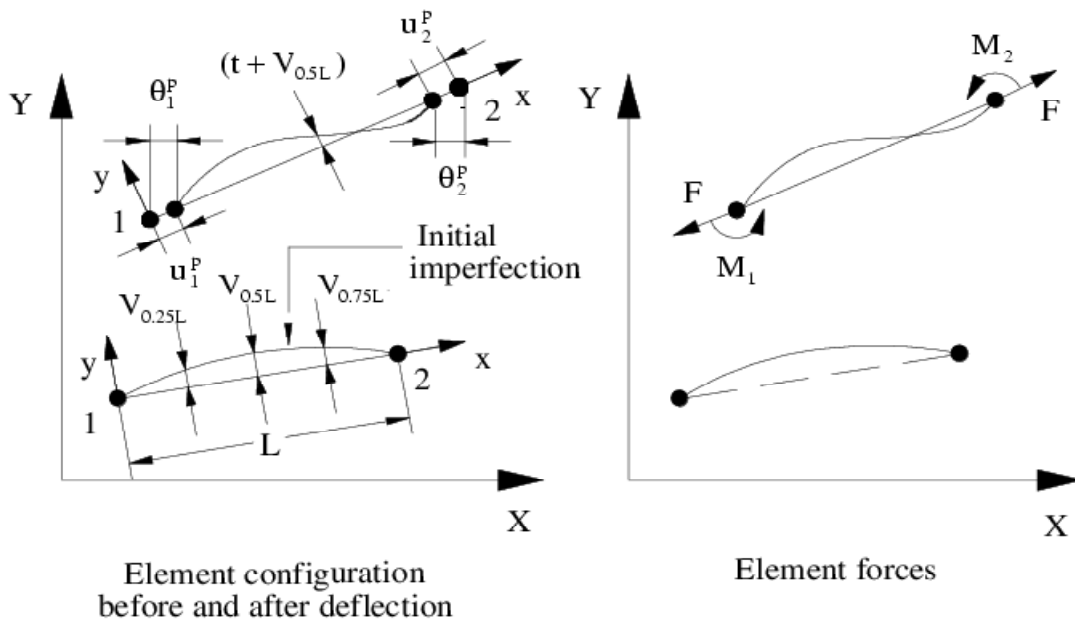

*Configuration and forces in local system of element type **qph2***

qdp2

Description	Quartic elastic 2D beam-column element utilising automatic q mesh refinement.
Subdivision pattern	Relative lengths in ratio form of zones where inelasticity is checked for automatic mesh refinement.
Nodes	2
Imperfections	$V_{0.25L}$, $V_{0.5L}$, $V_{0.75L}$ can be specified
Characteristics	<p>Geometric and material nonlinearities.</p> <p>Large displacement and beam-column effect of perfect/imperfect members.</p> <p>One element type <i>qdp2</i> is usually sufficient to represent a whole member.</p> <p>Element <i>qdp2</i> subdivides into elements cbp2, specified under cbp2.grp.name, if inelasticity is detected in the zones defined by the subdivision pattern pat.name.</p> <p>Accuracy increases with the number of sub-elements type cbp2 specified in the subdivision pattern.</p> <p>After subdivision, elements cbp2 are inserted in the inelastic zones, while the elastic zones are kept as element type <i>qdp2</i>.</p>
Application	Adaptive modelling of inelastic members in plane frames.
Restrictions	Applies only to cross-sections with materials stl1 , stl2 & stl3 .
Group header	<p>cbp2.grp.name: Specifies the group identifier of elements type cbp2 used in automatic mesh refinement.</p> <p>pat.name: An identifier referring to a subdivision pattern in the patterns module.</p>

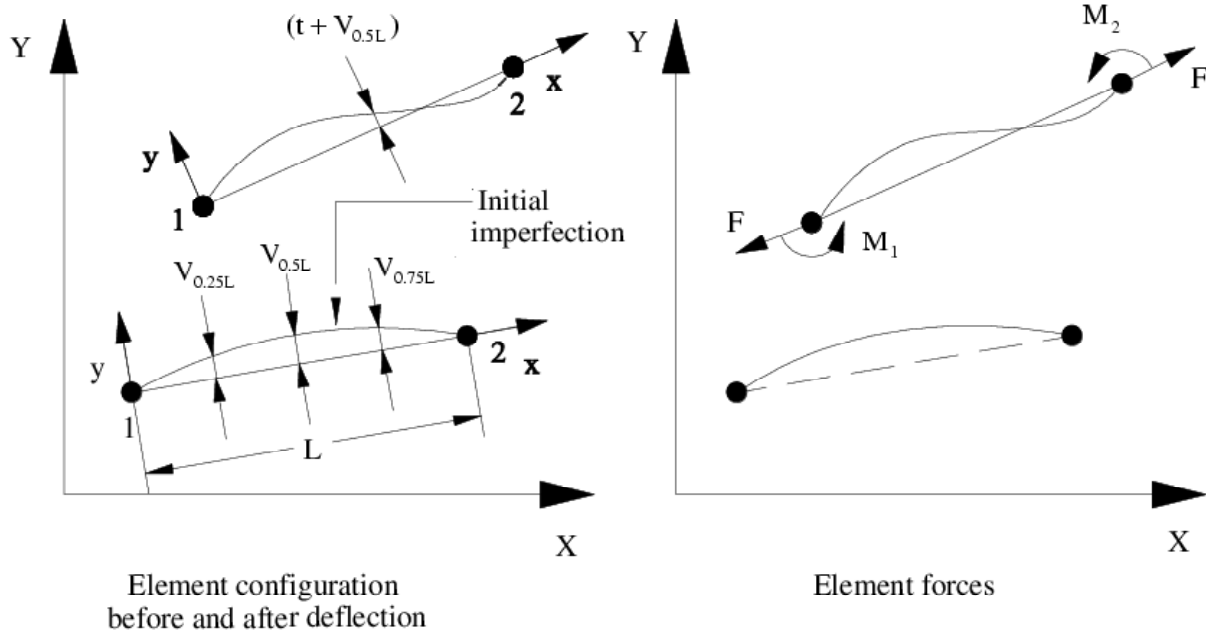

*Configuration and forces in local system of element type **qdp2***

lnk2

Description	2D link element with discrete axial/rotational springs.
Nodes	2
Characteristics	Geometric nonlinearity. 3 independent spring stiffnesses, each taking either a constant numerical value or a rigid value.
Application	Rigid link. Elastic bar with pinned ends.
Restrictions	
Group header	stiffness.parameters : numerical or rigid values for each of the spring stiffnesses, $k_{\theta 1}$, $k_{\theta 2}$ and k_{Δ} , in this order.

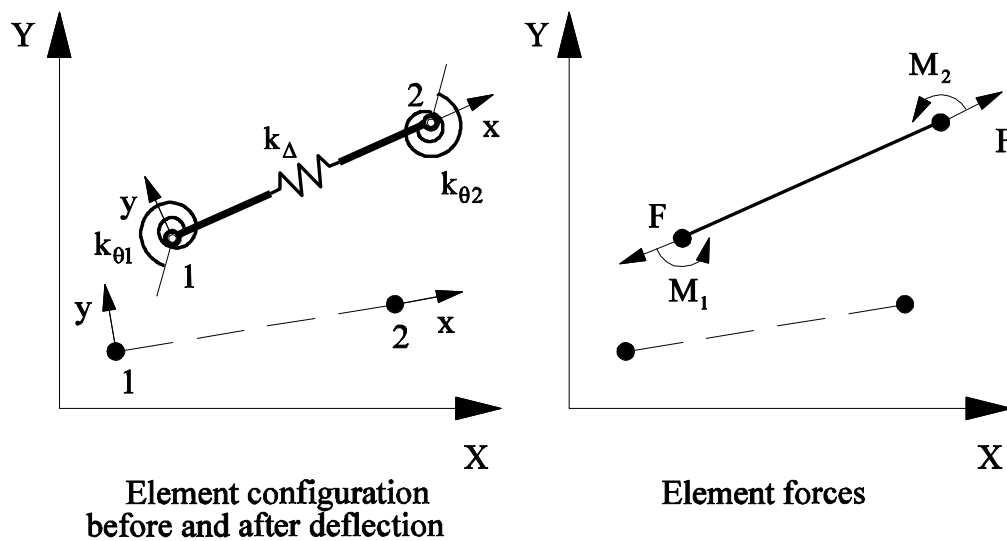

Configuration and forces in local system of element type *lnk2*

spe2

Description	Linear 2D nodal spring element.
Stiffness parameters	Two global translational stiffnesses and one rotational stiffness can be specified in the following order: K_x, K_y, K_{zz}
Nodes	1
Characteristics	Models elastic boundaries for plane frame analysis. Requires the definition of only one node, with the other node assumed fixed against translation and rotation.
Application	Plane frame boundaries.
Restrictions	Cannot be used to join two elements. For that purpose use jel2 .
Group header	<code>stiffness.parameters:</code> Defines stiffness parameters.

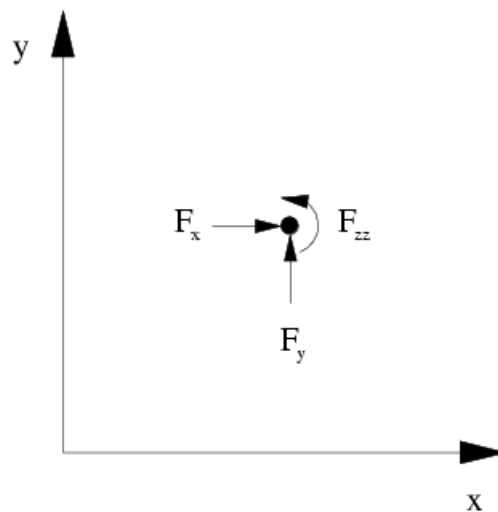

Forces for element type spe2

Description	2D joint element with uncoupled axial, shear and moment actions.
Curve types	Models used for the joint force-displacement curves, specified for F (axial), V (shear) and M (moment), respectively. Each of these models may be any of those described in Chapter 4 .
Parameters	Parameters for each of the three models specified for F, V and M.
Nodes	3
Characteristics	Nodes (1) and (2) must be initially coincident. Node (3) is only used to define the x-axis of the joint and can be a non-structural node. The orientation of the joint x-axis after deformation is determined by its initial orientation and the global rotation of node (1).
Application	Plane frame analysis. Can be used to model pin joints, inclined supports, elasto-plastic joint behaviour, soil-structure interaction and structural gaps, through employing appropriate joint curves.
Restrictions	Element has a zero initial length, since nodes (1) and (2) must be coincident. Cannot be used to model coupled axial, shear and moment actions.
Group header	<code>curve.types</code> : Defines curve types for joint elements. <code>parameters</code> : Defines parameters for the joint elements.

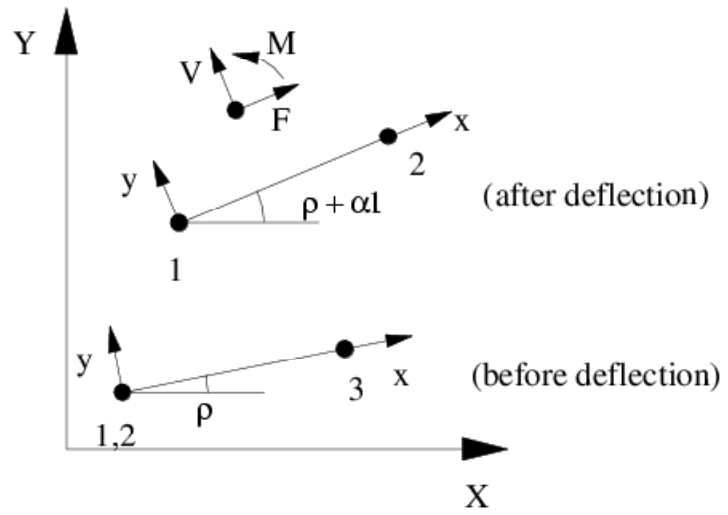

Forces for element type $j12$

Description	Concentrated (lumped) 2D mass element.
Nodes	1
Characteristics	Models lumped mass for dynamic analysis. Allows full 2×2 translational mass matrix to be defined. Lumped element mass, specified according to one of: M_x (default $M_y = M_x$ & $M_{xy} = 0$) M_x, M_y (default $M_{xy} = 0$) M_x, M_y, M_{xy} Rotational mass: M_{zz} Allows specification of mass-proportional damping at group level.
Application	Dynamic analysis of plane frames. Rotational mass may be required for connected elements to be explicit . Off-diagonal mass is reset to zero ($M_{xy} = 0$) if <code>lumped.mass</code> is true in the default.parameters module.
Restrictions	
Group header	<code>mass</code> : element mass. <code>[rotational.mass]</code> : optional rotational mass. <code>[damping.parameter]</code> : optional parameter for mass-proportional Rayleigh damping; defaults to the value of <code>mass.damping.parameter</code> specified in the default.parameters module.

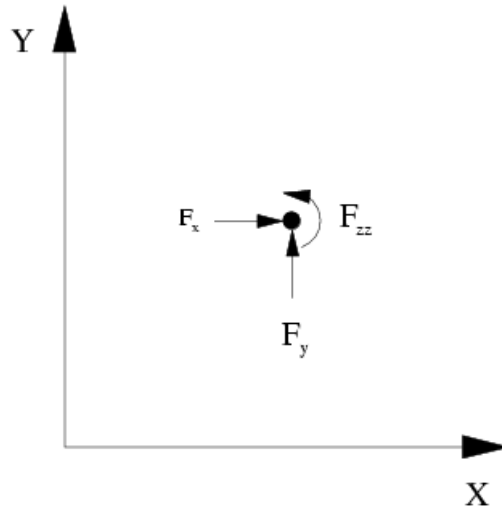

*Forces for element type **cnm2***

cnd2

Description	Concentrated (dashpot) 2D viscous damping element.
Damping parameters	Two translational and one rotational damping coefficients, specified in this order: C_x , C_y , C_{zz}
Nodes	1
Characteristics	Models nodal viscous damping for dynamic analysis.
Application	Dynamic analysis of plane frames.
Restrictions	
Group header	<code>damping.parameters</code> : Defines dashpot damping parameters.

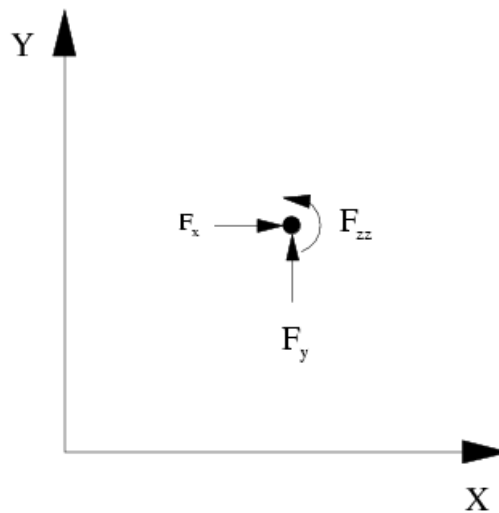

*Forces for element type **cnd2***

Description	Linear 2D mass element.
Nodes	2
Characteristics	<p>Simplified modelling of uniformly distributed mass for dynamic analysis. Assumes the mass to lie on a rigid straight line between the two end nodes.</p> <p>Rotational mass may be required for connected elements to be explicit.</p> <p>Element can be explicit provided <code>lumped.mass</code> is true (as specified or by default).</p> <p>Allows specification of mass-proportional damping at group level.</p>
Application	Dynamic analysis of plane frames.
Restrictions	
Group header	<p><code>mass/length</code>: mass per unit length.</p> <p><code>[rotational.mass/length]</code>: optional rotational mass per unit length.</p> <p><code>[damping.parameter]</code>: optional parameter for mass-proportional Rayleigh damping; defaults to the value of <code>mass.damping.parameter</code> specified in the default.parameters module.</p> <p><code>[lumped.mass]</code>: optional (true false) flag indicating whether mass is to be lumped; defaults to value of <code>lumped.mass</code> in the default.parameters module.</p>

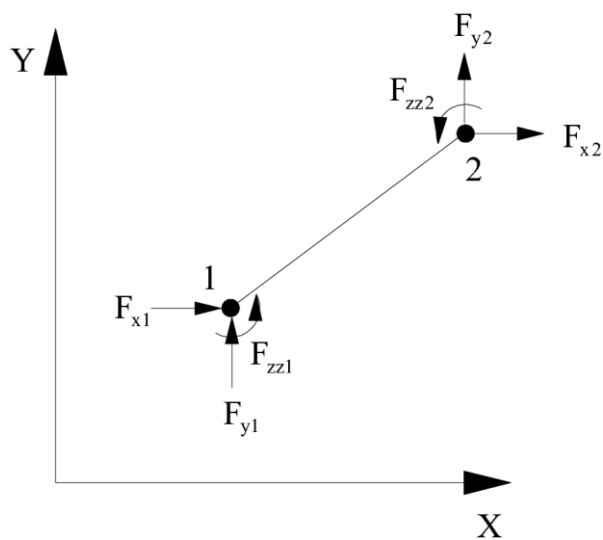

Forces for element type lnm2

Description	Cubic 2D distributed mass element
Nodes	2
Characteristics	<p>Models uniformly distributed mass in dynamic analysis.</p> <p>Uses an Updated Lagrangian formulation with a cubic shape function for the transverse displacement and a linear distribution for the axial displacement.</p> <p>Allows different axial (m_a) and transverse (m_t) distributed mass.</p> <p>Mass per unit length, specified according to one of:</p> <p style="margin-left: 40px;">m_a (default $m_t = m_a$)</p> <p style="margin-left: 40px;">m_a, m_t</p> <p>Allows specification of mass-proportional damping at group level.</p>
Application	Dynamic analysis of plane frames.
Restrictions	
Group header	<p>mass/length: Mass per unit length.</p> <p>[damping.parameter]: optional parameter for mass-proportional Rayleigh damping; defaults to the value of mass.damping.parameter specified in the default.parameters module.</p>

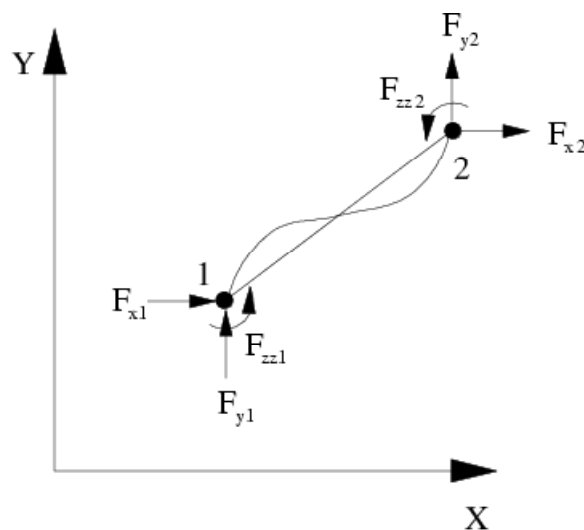

Forces for element type **cbm2**

Description	Rayleigh damping 2D element
Mass/length	Mass per unit length
Parameters	Two proportionality constants (a_1 & a_2) of mass and stiffness respectively, specified in that order.
Nodes	2
Characteristics	Models Rayleigh damping effects. All rld2 elements must have the same constant (a_1 & a_2) to model conventional Rayleigh damping.
Application	Dynamic analysis of plane frames.
Restrictions	(a_1) should be set to zero for dynamic analysis involving ground excitation, otherwise damping would be proportional to absolute rather than relative frame velocity.
Group header	sec.name :An identifier referring to one of the cross-sections declared in the sections module. mass/length : Mass per unit length. parameters : Defines parameters of Rayleigh damping elements.

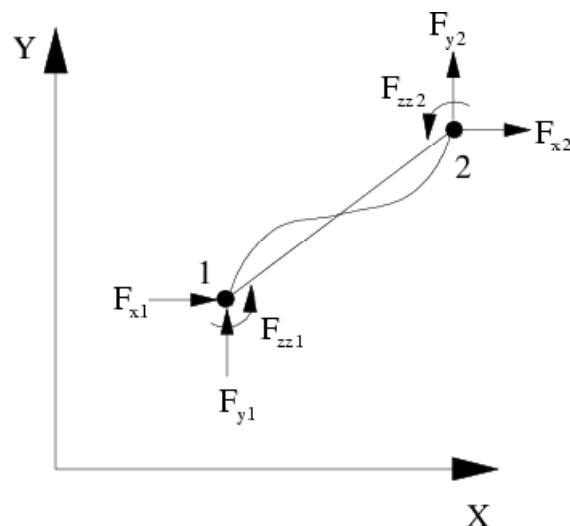

Forces for element type rld2

Description	2D/3D joint element with coupling between axial force and moment but uncouple with shear.
Types	Three entries are required: <ol style="list-style-type: none">1) 'steel' for bare steel or 'composite' for composite connection.2) connection type:<ul style="list-style-type: none">'flush.endplate''extended.endplate''web.angles''top.and.seat''combined.web/top/seat''finplate'3) behaviour of panel zone, either 'rigid' if panel zone behaviour is omitted or 'flexible' if the flexibility of the panel zone is included.
Material name	Three material properties are required by using material model gen1 . The first material provides the properties of the connecting elements e.g. plates, angle. The second material is the properties of bolts. The third material is the properties of the connected member i.e. column and beam.
Parameters	Number of parameters vary according to connection type: <ul style="list-style-type: none">• Flush endplate (13 parameters)• Extended endplate (26 parameters)• Double web angles (12 parameters)• Top and seat angles (23 parameters)• Combination of top, seat and web angles (34 parameters)• Finplate (8 parameters) <ol style="list-style-type: none">1. Flush end plate<ul style="list-style-type: none">• Bolt diameter,• Area of bolt shank,• Thickness of bolt head,• Thickness of nut,• Thickness of washer,• Distance from endplate edge to bolt head/nut/washer edge,• Distance of bolt head/nut /washer whichever is appropriate,• Distance from edge of bolt head/nut/ washer to fillet of endplate to beam web,• Total depth of endplate,• Thickness of endplate,• Endplate width,

- Minimum bolt pitch,
- Coefficient for the computation of the effective width for the bolt-row below the beam tension flange.

2. Extended end plate

The geometrical properties of the extended endplate are double the properties of the flush endplate, accounting for different orientation of the T-stub components, but the details and order are the same. The only exception is for the last parameter, where the length of the extended part of the endplate is required.

3. Double web angles

- Bolt diameter,
- Area of bolt shank,
- Total depth of angle,
- Angle thickness,
- Gauge length of beam leg,
- Bolt clearance,
- Minimum bolt pitch,
- Gauge length of column leg,
- Distance from bolt line to free edge of column leg,
- Distance from bolt line to free edge of beam leg,
- Angle radius,
- Diameter of M16 bolts.

4. Top and seat angles

For top angle (12 parameters):

- Bolt diameter,
- Area of bolt shank,
- Total depth of angle,
- Angle thickness,
- Gauge length of beam leg,
- Bolt clearance,
- Minimum bolt pitch,
- Gauge length of column leg,
- Distance from bolt line to free edge of column leg,
- Distance from bolt line to free edge of beam leg,
- Angle radius,
- Diameter of M16 bolts.

Similar dimensions are needed for seat angle (11 parameters) except for the diameter of M16 bolts.

5. Combination of top, seat and web angles

Connection parameters for this type are the combination of web angle and top and seat angles.

6. Finplate

- Bolt diameter,
- Bolt hole diameter,
- Total depth of plate,
- Plate thickness,
- Gauge length,
- Width of plate,
- Minimum bolt pitch,
- Diameter of M16 bolts.

After the connection parameters are entered, another 14 parameters are needed: 11 parameters for the connected members, followed by Poisson ratio, number of layers and a flag to indicate preload or non-preload condition of the bolts.

Connected member parameters are:

- Column depth,
- Column flange width,
- Thickness of column flange,
- Thickness of column web,
- Column radius,
- Bolt pitch in column,
- Distance from bolt line to free edge of column flange,
- Distance from bolt line to fillet of column flange,
- Beam depth,
- Thickness of beam flange,
- Thickness of beam web.

Nodes

3 (2D) used similar to [jel2](#)

4 (3D) used similar to [jel3](#)

Application

Plane frame analysis.

Space frame analysis.

Can be used to model steel and composite joints.

Restrictions

Element has a zero initial length, since nodes (1) and (2) must be coincident.

Group header

type: Defines the type of connection and contribution of shear panel

mat.name (s): Defines the material for the connecting elements, bolts and connected member

parameters: Defines parameters for the joint and depends on the connection types.

Description	Cubic elasto-plastic 3D beam-column element.
Monitoring points	100 points usually adequate; depends on section type.
Nodes	3
Characteristics	<p>Geometric and material nonlinearities.</p> <p>Numerical integration performed over two Gauss points.</p> <p>A number of monitoring areas used at each Gauss section to monitor material direct stress and strains.</p> <p>Predicts global member behaviour based on a material stress-strain relationship.</p> <p>A number of elements per member, usually over 5, must be used for reasonable accuracy in inelastic modelling.</p> <p>Nodes (1) and (2) define the element connectivity and its local x-axis. The y-axis lies in a plane defined by the x-axis and node (3), which can be a non-structural node.</p>
Application	Modelling of inelastic members in space frames.
Restrictions	The elastic torsional rigidity is used, which is approximate for composite and R/C sections. Warping strains are not accounted for.
Group header	<p><code>sec.name</code> :An identifier referring to one of the cross-sections declared in the <code>sections</code> module.</p> <p><code>monitoring.points</code> Defines the number of points for monitoring stresses and strains within a cross-section.</p>

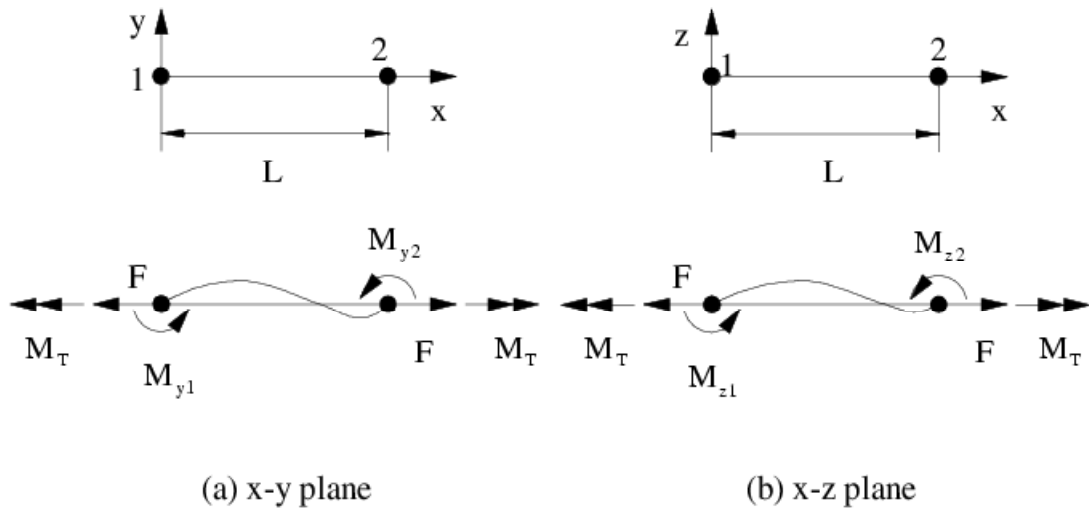

*Forces in local system of element type **cbp3***

Description	Quartic elastic 3D beam-column element.
Nodes	3
Imperfections	$V_{y0.25L}$, $V_{y0.5L}$, $V_{y0.75L}$, $V_{z0.25L}$, $V_{z0.5L}$, and $V_{z0.75L}$ can be specified.
Characteristics	<p>Geometric nonlinearities.</p> <p>Large displacements and beam-column effect of perfect/imperfect members.</p> <p>One element type <i>qel3</i> is usually sufficient to represent the beam-column effect and large displacement response of a whole elastic member.</p> <p>Nodes (1) and (2) define the element connectivity and its local x-axis. The y-axis lies in a plane defined by the x-axis and node (3), which can be a non-structural node.</p>
Application	Geometric nonlinearities in elastic space frames.
Restrictions	<p>Unable to model concrete cracking.</p> <p>Warping strains are not accounted for.</p>
Group header	sec.name :An identifier referring to one of the cross-sections declared in the sections module.

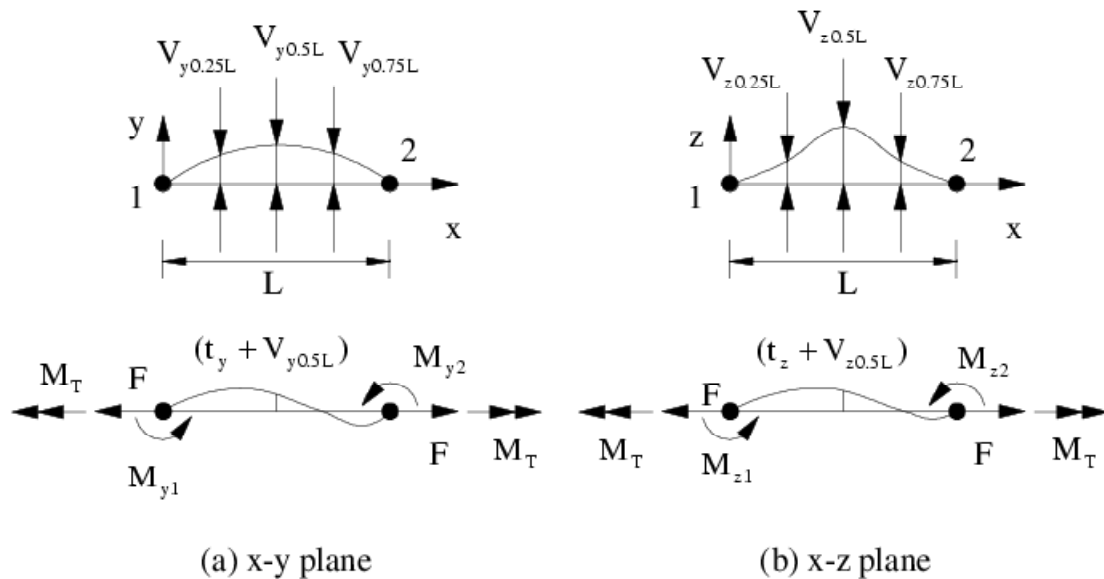

Imperfection and forces in local system of element type *qel3*

qph3

Description	Quartic plastic hinge 3D beam-column element with an option for automatic subdivision.
Nodes	3
Subdivision	Automatic subdivision into two elements if a plastic hinge is detected within the element may be requested.
Imperfections	$V_{y0.25L}$, $V_{y0.5L}$, $V_{y0.75L}$, $V_{z0.25L}$, $V_{z0.5L}$, and $V_{z0.75L}$ can be specified.
Characteristics	<p>Geometric and material nonlinearities.</p> <p>Suitable for members in which the spread of plasticity is not important and the section response is elastic-plastic without strain-hardening.</p> <p>Rotational and axial plastic hinge displacements are allowed at the two ends of the element.</p> <p>One element type <i>qph3</i> is usually sufficient to model a whole member, and the option of subdivision allows for the case of member buckling.</p> <p>Nodes (1) and (2) define the element connectivity and its local x-axis. The y-axis lies in a plane defined by the x-axis and node (3), which can be a non-structural node.</p>
Application	Large displacement plastic-hinge analysis of space frames
Restrictions	Not applicable to reinforced concrete or composite members. Warping strains are not accounted for.
Group header	<p>sec.name: An identifier referring to one of the cross-sections declared in the sections module.</p> <p>subdivision: Gives the option for automatic subdivision plastic hinge elements:</p> <p>=(t true) consider element subdivision</p> <p>=(f false) ignore element subdivision</p>

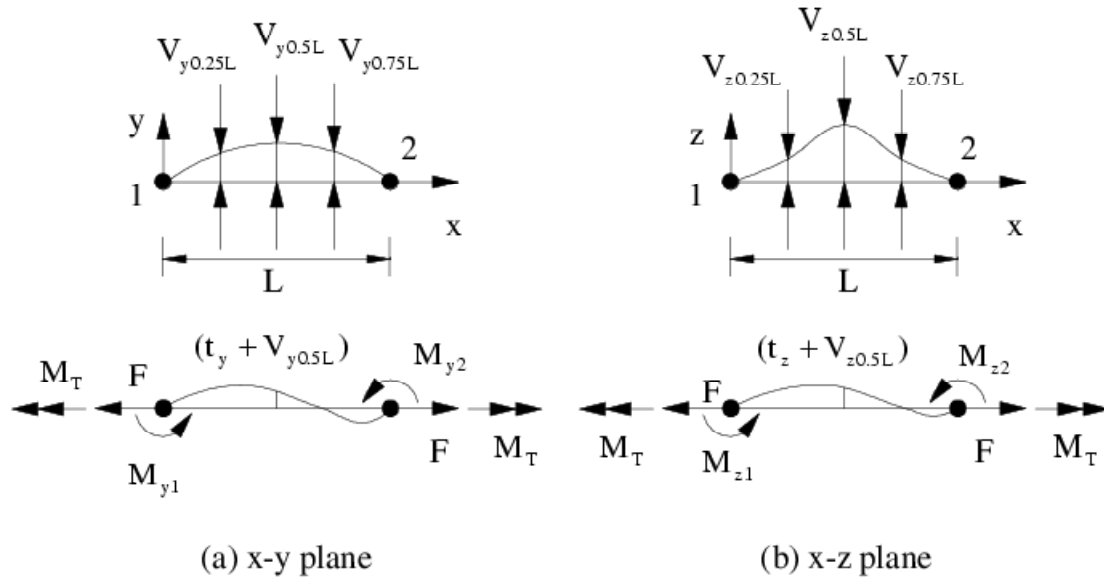

*Imperfection and forces in local system of element type **qph3***

qdp3

Description	Quartic elastic 3D beam-column element utilising automatic mesh refinement.
Subdivision pattern	Relative lengths in ratio form of zones where inelasticity is checked for automatic mesh refinement.
Nodes	3
Imperfections	$V_{y0.25L}$, $V_{y0.5L}$, $V_{y0.75L}$, $V_{z0.25L}$, $V_{z0.5L}$, and $V_{z0.75L}$ can be specified.
Characteristics	<p>Geometric and material nonlinearities.</p> <p>Large displacement and beam-column effect of perfect/imperfect members.</p> <p>One element type qdp3 is usually sufficient to represent a whole member.</p> <p>Element qdp3 subdivides into elements cbp3, specified under cbp3.grp.name, if inelasticity is detected in the zones defined by the subdivision pattern pat.name.</p> <p>Accuracy increases with the number of sub-elements type cbp3 specified in the subdivision pattern.</p> <p>After subdivision, elements cbp3 are inserted in the inelastic zones, while the elastic zones are kept as element type qdp3.</p> <p>Nodes (1) and (2) define the element connectivity and its local x-axis. The y-axis lies in a plane defined by the x-axis and node (3), which can be a non-structural node.</p>
Application	Adaptive modelling of inelastic members in space frames.
Restrictions	Applies only to cross-sections with materials stl1 , stl2 & stl3 . Warping strains are not
Group header	cbp3.grp.name : Specifies the group identifier of elements type cbp3 used in automatic mesh refinement. pat.name : An identifier referring to a subdivision pattern in the patterns module.

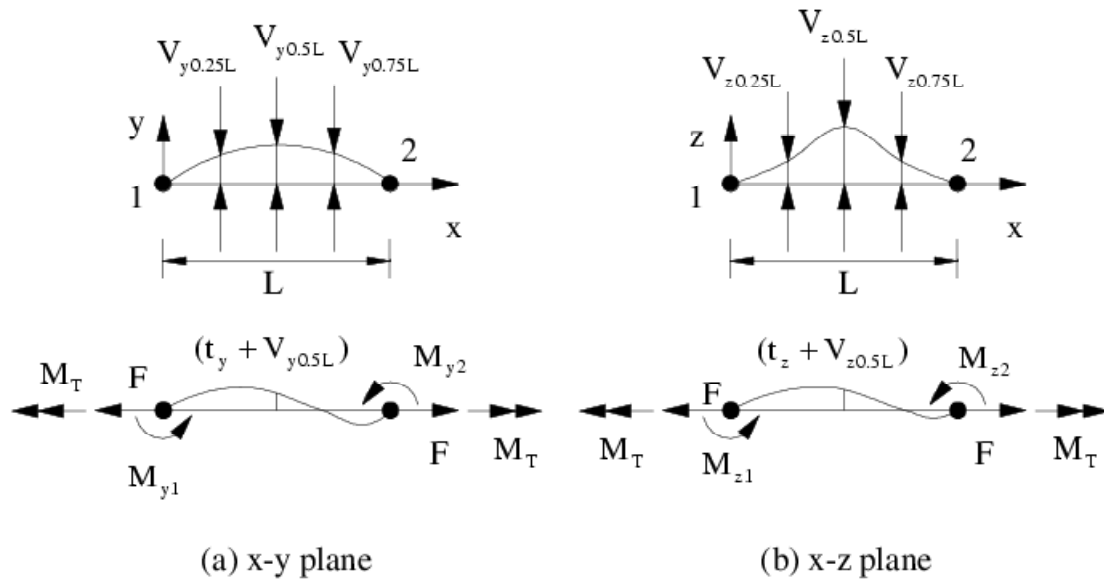

Imperfection and forces in local system of element type qdp3

Description	Cubic elasto-plastic 3D beam-column element for thin-walled open cross-sections with warping.
Monitoring points	100 points usually adequate; depends on section type.
Nodes	3
Characteristics	<p>Geometric and material nonlinearities.</p> <p>Numerical integration performed over two Gauss points.</p> <p>A number of monitoring areas used at each Gauss section to monitor material direct stress and strains.</p> <p>Works with uniaxial material models (stl1, stl3), and with biaxial material models (bnsi, bnsk) which consider the influence of plasticity on twisting rigidity.</p> <p>Predicts global member behaviour based on a material stress-strain relationship.</p> <p>Lateral torsional buckling including Wagner effect.</p> <p>A number of elements per member, usually over 5, must be used for reasonable accuracy in inelastic modelling.</p> <p>Nodes (1) and (2) define the element connectivity and its local x-axis. The y-axis lies in a plane defined by the x-axis and node (3), which can be a non-structural node.</p>
Application	<p>Modelling of inelastic thin-walled members with open cross-sections in space frames.</p> <p>Warping freedoms (wp1, wp2) can be coupled for adjacent elements to model torsion with non-uniform warping, using:</p> <pre>coupled.additional.freedoms</pre>
Restrictions	<p>Uses the oplt thin-walled cross-section.</p> <p>Elastic twisting rigidity is considered when employing uniaxial material models.</p>
Group header	<p>sec.name: An identifier referring to the oplt cross-section.</p> <p>monitoring.points: Defines the number of points for monitoring stresses and strains within a cross-section.</p> <p>Options: optional heading which specifies whether the Wagner effect is to be excluded [no.wagner.effect], whether residual strains defined for the cross-section are to be considered [residual.strains], and the number of monitoring points over the thickness [thickness.points #] (Default = 1).</p>

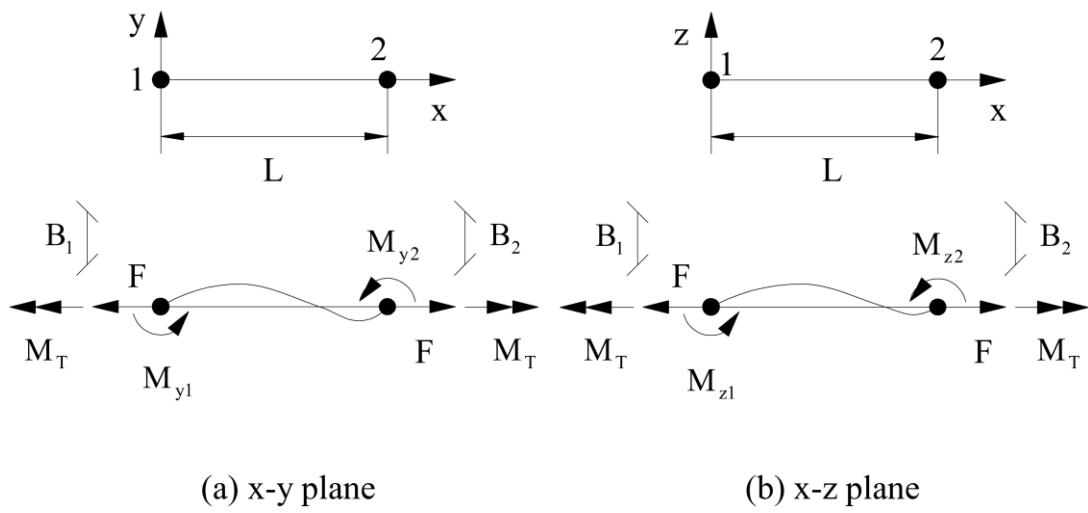

*Forces in local system of element type **pwp3***

lnk3

Description	3D link element with discrete axial/rotational springs.
Nodes	3
Characteristics	Geometric nonlinearity. Nodes (1) and (2) define the element connectivity and its local x-axis. The y-axis lies in a plane defined by the x-axis and node (3), which can be a non-structural node.
Application	Rigid link. Elastic bar with pinned ends.
Restrictions	
Group header	stiffness.parameters: numerical or rigid values for each of the spring stiffnesses, $k_{\theta y1}$, $k_{\theta z1}$, $k_{\theta y2}$, $k_{\theta z2}$, k_{Δ} and $k_{\theta T}$ in this order.

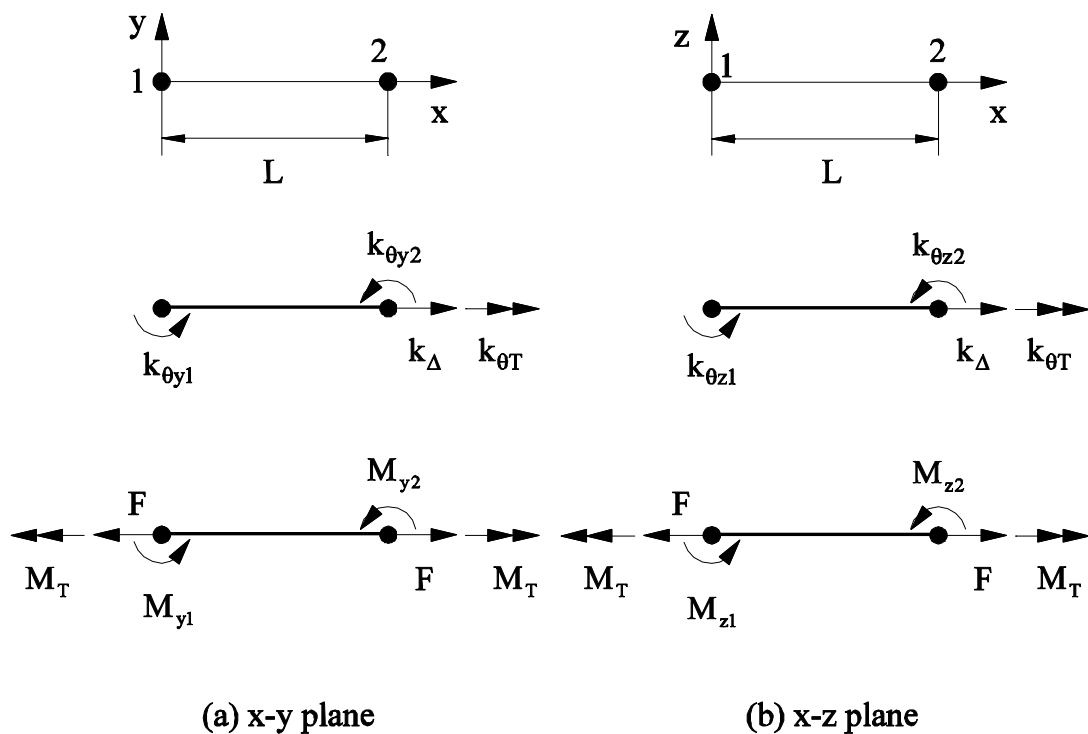

Stiffness parameters and forces in local system of element type *lnk3*

Inks

Description	3D link element linking 6 DOF to 5 DOF nodes.
Nodes	3.
Characteristics	Geometric nonlinearity. Nodes (1) and (2) define the element connectivity and its local x-axis. The y-axis lies in a plane defined by the x-axis and node (3), which can be a non-structural node.
Application	Beam to slab connection. The second node is a 5 DOF node belonging to plate/shell elements with only two rotational DOF's, including csl4 elements.
Restrictions	
Group header	stiffness.parameters: numerical or rigid values for each of the spring stiffnesses, $k_{\theta y1}$, $k_{\theta z1}$, $k_{\theta y2}$, $k_{\theta z2}$ and k_{Δ} in this order.

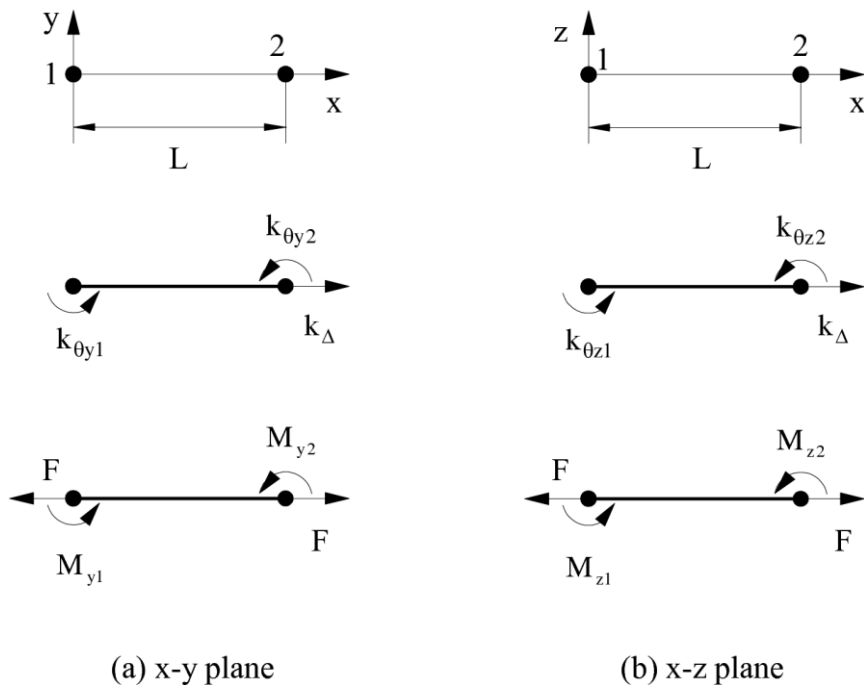

*Stiffness parameters and forces in local system of element type **Inks***

Description	3D joint element with uncoupled axial, shear and moment actions.
Curve types	Models used for the joint force-displacement curves, specified for F_x (axial), F_y & F_z (shear) and M_x , M_y & M_z (moment), respectively. Each of these models may be any of those described in Chapter 4 .
Parameters	Parameters for each of the six models specified for F_x , F_y , F_z , M_x , M_y , M_z .
Nodes	4
Characteristics	Nodes (1) and (2) must be initially coincident. Node (3) is only used to define the x-axis of the joint and can be a non-structural node. The y-axis lies in a plane defined by the x-axis and node (4), which also can be a non-structural node. The orientation of the joint x-axis after deformation is determined by its initial orientation and the global rotations of node (1).
Application	Space frame analysis. Can be used to model pin joints, inclined supports, elasto-plastic joint behaviour, soil-structure interaction and structural gaps, through employing appropriate joint curves.
Restrictions	Element has a zero initial length, since nodes (1) and (2) must be coincident. Cannot be used to model coupled axial, shear and moment actions.
Group header	<code>curve.types</code> : Defines curve types for joint elements. <code>parameters</code> : Defines parameters for the joint elements.

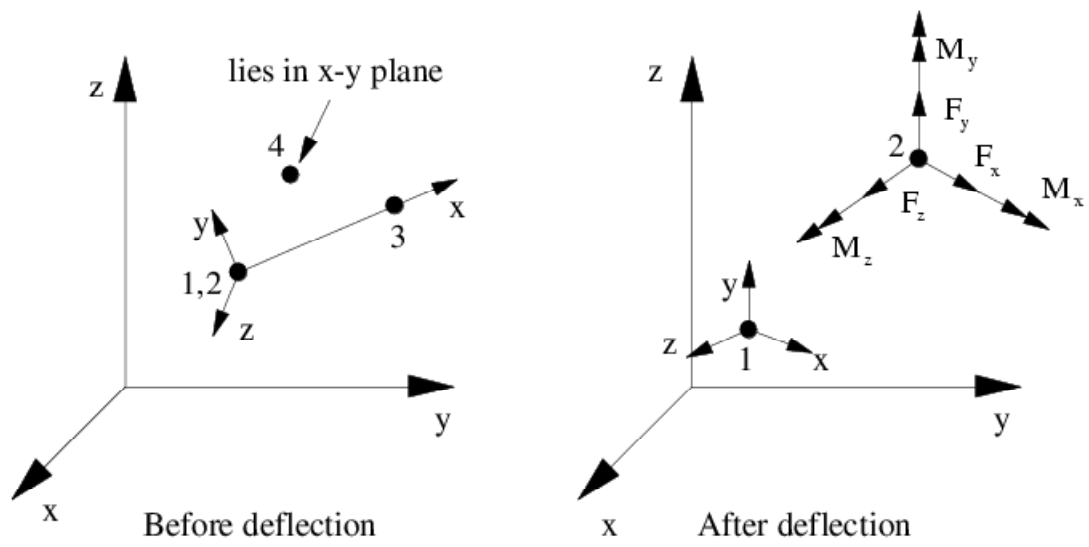

*Configuration and forces for element type **j13***

Description	Concentrated (lumped) 3D mass element.
Nodes	1
Characteristics	<p>Models lumped mass for dynamic analysis.</p> <p>Allows full 3×3 translational mass matrix to be defined.</p> <p>Lumped element mass, specified according to one of:</p> <p style="padding-left: 40px;">M_x (default $M_y = M_z = M_x$ & $M_{xy} = M_{xz} = M_{yz} = 0$)</p> <p style="padding-left: 40px;">M_x, M_y, M_z (default $M_{xy} = M_{xz} = M_{yz} = 0$)</p> <p style="padding-left: 40px;">$M_x, M_y, M_z, M_{xy}, M_{xz}, M_{yz}$</p> <p>Diagonal rotational mass specified as follows:</p> <p style="padding-left: 40px;">Only M_x is specified above:</p> <p style="padding-left: 80px;">M_{xx} (default $M_{yy} = M_{zz} = M_{xx}$)</p> <p style="padding-left: 40px;">otherwise:</p> <p style="padding-left: 80px;">M_{xx}, M_{yy}, M_{zz}</p> <p>Allows specification of mass-proportional damping at group level.</p>
Application	<p>Dynamic analysis of space frames, shells and 3D continuum/membrane structures.</p> <p>Rotational mass may be required for connected elements to be explicit.</p> <p>Off-diagonal mass is reset to zero ($M_{xy} = M_{xz} = M_{yz} = 0$) if <code>lumped.mass</code> is true in the default.parameters module.</p>
Restrictions	<code>rotational.mass</code> should be zero for use with csl4 elements.
Group header	<p><code>mass</code>: element mass.</p> <p><code>[rotational.mass]</code>: optional rotational mass.</p> <p><code>[damping.parameter]</code>: optional parameter for mass-proportional Rayleigh damping; defaults to the value of <code>mass.damping.parameter</code> specified in the default.parameters module.</p>

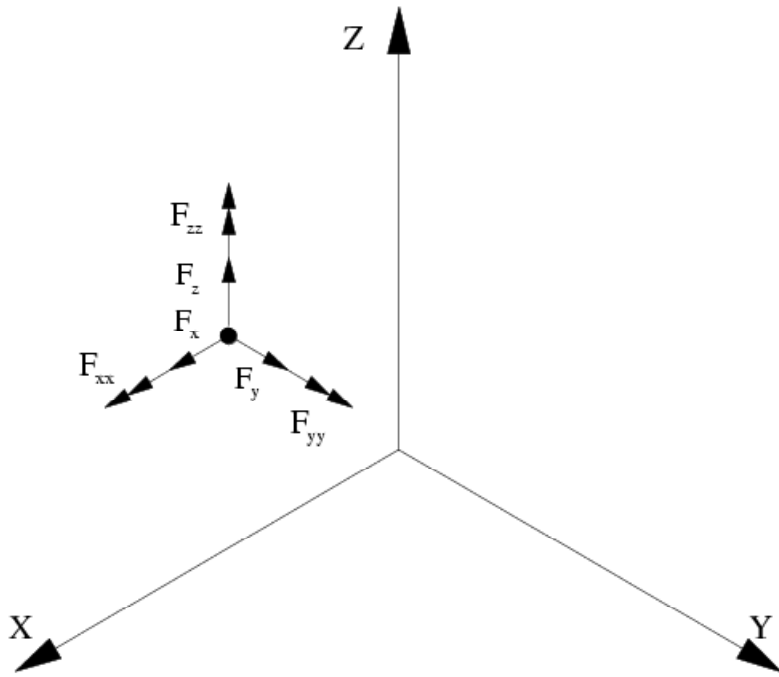

*Forces for element type **cnm3***

cnd3

Description	Concentrated (dashpot) 3D viscous damping element.
Damping parameters	Three translational and three rotational damping coefficients, specified in this order: C_x, C_y, C_z $[C_{xx}, C_{yy}, C_{zz}]$
Nodes	1
Characteristics	Models nodal viscous damping for dynamic analysis.
Application	Dynamic analysis of space frames and shells. Dynamic analysis of 3D continuum/membrane structures.
Restrictions	$[C_{xx}, C_{yy}, C_{zz}]$ are only optional for 3D continuum/membrane analysis . C_{xx}, C_{yy}, C_{zz} should be zero for use with csl4 elements.
Group header	<code>damping.parameters:</code> Defines dashpot damping parameters.

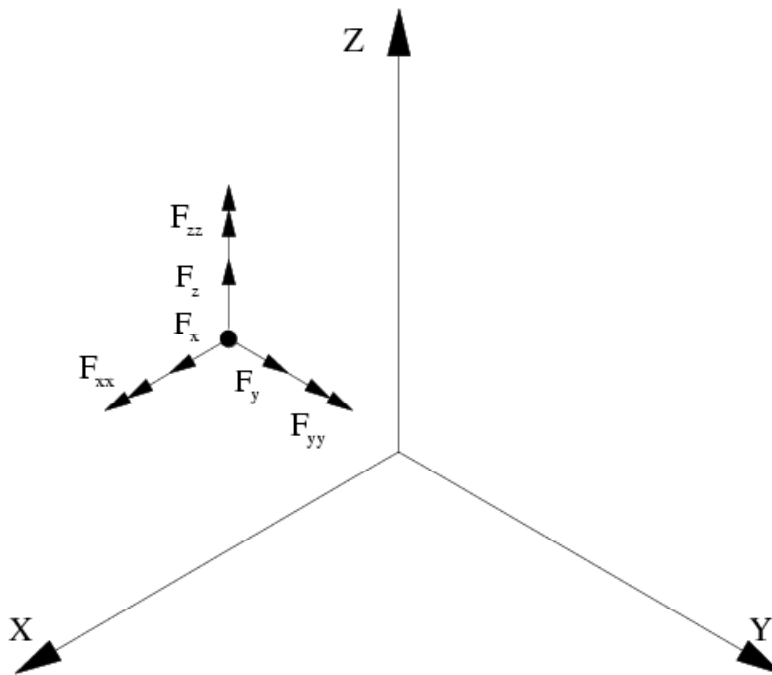

Forces for element type cnd3

lnm3

<i>Description</i>	Linear 3D mass element.
<i>Nodes</i>	2
<i>Characteristics</i>	<p>Simplified modelling of uniformly distributed mass for dynamic analysis.</p> <p>Assumes the mass to lie on a rigid straight line between the two end nodes.</p> <p>Rotational mass may be required for connected elements to be explicit.</p> <p>Element can be explicit provided <code>lumped.mass</code> is true (as specified or by default).</p> <p>Allows specification of mass-proportional damping at group level.</p>
<i>Application</i>	Dynamic analysis of space frames.
<i>Restrictions</i>	
<i>Group header</i>	<p><code>mass/length</code>: Mass per unit length.</p> <p><code>[rotational.mass/length]</code>: optional rotational mass per unit length.</p> <p><code>[damping.parameter]</code>: optional parameter for mass-proportional Rayleigh damping; defaults to the value of <code>mass.damping.parameter</code> specified in the default.parameters module.</p> <p><code>[lumped.mass]</code>: optional (true false) flag indicating whether mass is to be lumped; defaults to value of <code>lumped.mass</code> in the default.parameters module.</p>

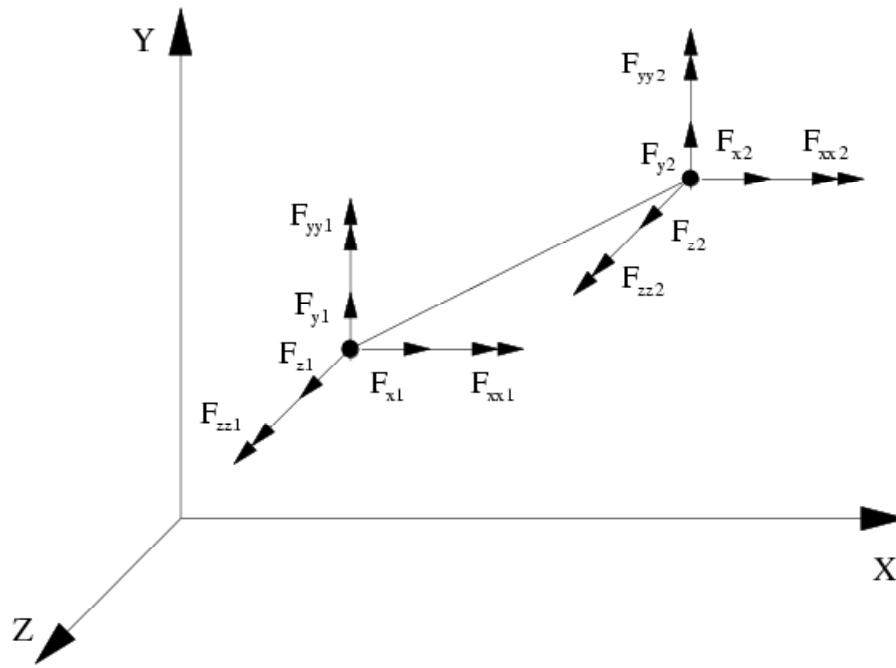

*Forces for element type **lnm3***

cbm3

Description	Cubic 3D distributed mass element.
Nodes	2
Characteristics	<p>Models uniformly distributed mass in dynamic analysis.</p> <p>Uses an Updated Lagrangian formulation with a cubic shape function for the transverse displacement and a linear distribution for the axial displacement.</p> <p>Allows different axial (m_a) and transverse (m_t) distributed mass.</p> <p>Mass per unit length, specified according to one of:</p> <p style="padding-left: 40px;">m_a (default $m_t = m_a$)</p> <p style="padding-left: 40px;">m_a, m_t</p> <p>Allows specification of mass-proportional damping at group level.</p>
Application	Dynamic analysis of space frames.
Restrictions	
Group header	<p><code>mass/length</code>: Mass per unit length.</p> <p><code>[damping.parameter]</code>: optional parameter for mass-proportional Rayleigh damping; defaults to the value of <code>mass.damping.parameter</code> specified in the default.parameters module.</p>

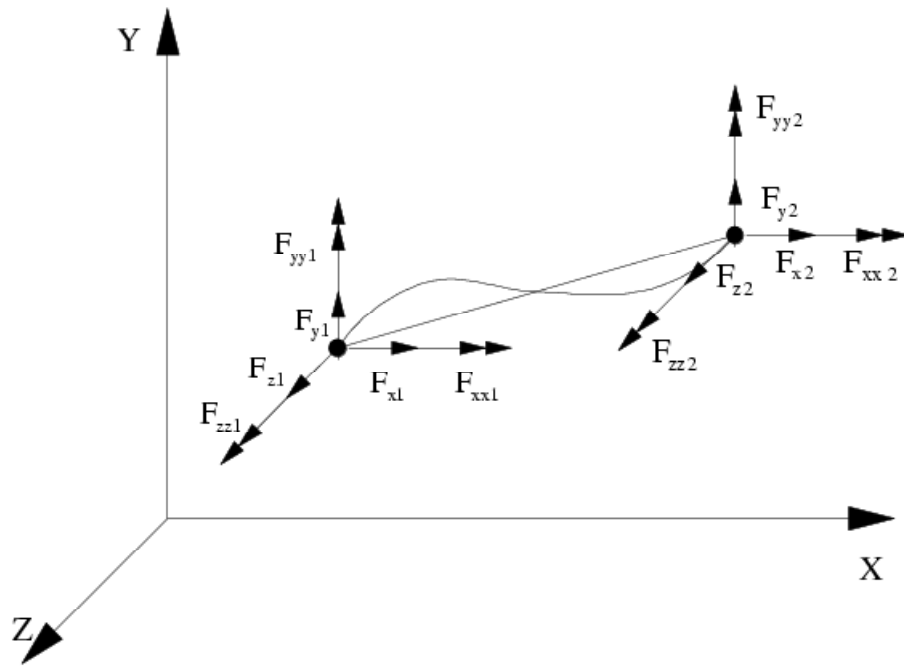

*Forces for element type **cbm3***

rld3

Description	Rayleigh damping 3D element
Mass/length	Mass per unit length
Parameters	Two proportionality constants (a_1 & a_2) of mass and stiffness respectively, specified in that order.
Nodes	3
Characteristics	<p>Models Rayleigh damping effects.</p> <p>All <i>rld3</i> elements must have the same constant (a_1 & a_2) to model conventional Rayleigh damping.</p> <p>Nodes (1) and (2) define the element connectivity and its local x-axis. The y-axis lies in a plane defined by the x-axis and node (3), which can be a non-structural node.</p>
Application	Dynamic analysis of plane frames.
Restrictions	(a_1) should be set to zero for dynamic analysis involving ground excitation, otherwise damping would be proportional to absolute rather than relative frame velocity.
Group header	<p>sec.name :An identifier referring to one of the cross-sections declared in the sections module.</p> <p>mass/length: Mass per unit length.</p> <p>parameters: Defines parameters of Rayleigh damping elements.</p>

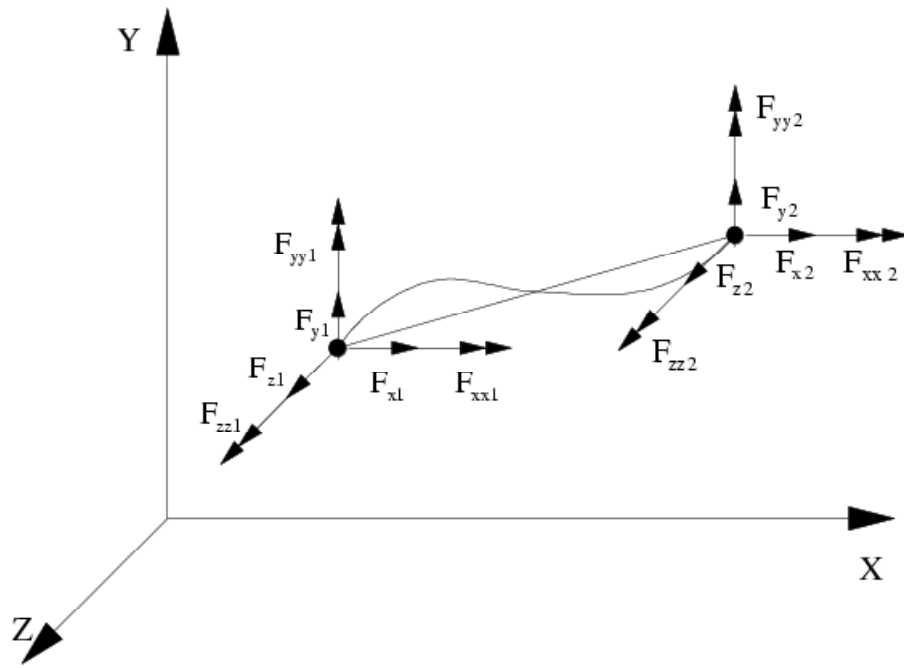

Forces for element type rld3

Description	2-D flat shell element for composite floor slabs.
Nodes	4
Characteristics	<p>Geometrically orthotropic slab.</p> <p>4-noded composite and R/C slab element with additional rib and cover freedoms. It deals with the nonlinear analysis of composite floor slabs, enabling the modelling of material nonlinearities and geometric orthotropy through a modification of the Reissner-Mindlin hypothesis.</p> <p>The element can be used in a basic form employing bilinear shape functions or in a higher-order form employing quadratic shape functions for the normal rotations. This is achieved through the use of hierarchic additional freedoms, which are defined in this order:</p> $\mathbf{f}_a = \left\langle (\bar{\mathbf{w}})_{1 \rightarrow 4}, (\mathbf{u}_r, \mathbf{v}_r)_{1 \rightarrow 2}, (\bar{\mathbf{u}}, \bar{\mathbf{v}}, \bar{\mathbf{w}}, \bar{\theta}_x, \bar{\theta}_y)_{1 \rightarrow 4}, (\bar{\mathbf{u}}_r, \bar{\mathbf{v}}_r)_{1 \rightarrow 3} \right\rangle^T$ <p>For the bilinear form, only the first 8 additional freedoms are used, with the remaining 26 additional freedoms employed in addition for the quadratic form. Individual additional freedoms may be restrained as described in the <i>restraints</i> module.</p> <p>Elevated temperature may be specified using element load type <i>tmp7</i> specified in this order:</p> $\langle T_1, \Delta T_1, T_2, \Delta T_2, T_3, \Delta T_3, T_4, \Delta T_4, T_5, \Delta T_5, T_6, \Delta T_6, T_7, T_8 \rangle$ <p>where T_i and ΔT_i indicate respectively temperatures and temperature increments between the bottom of the cover and the top of the slab.</p>
Application	Realistic modeling of composite floor slabs under extreme loading, including fire conditions.
Restrictions	
Group header	<p>sec.name: An identifier referring to a cross-section of type cslb declared in the sections module.</p> <p>type: one of the following: <code>left.edge.rib</code>, <code>cover</code>, <code>central.rib</code>, and <code>right.edge.rib</code>.</p> <p>gauss.points: 3 entries representing number of gauss points in the local x, y and z directions, respectively.</p> <p>[options]: optional parameter indicating the element order [bilinear quadratic]; defaults to bilinear.</p>

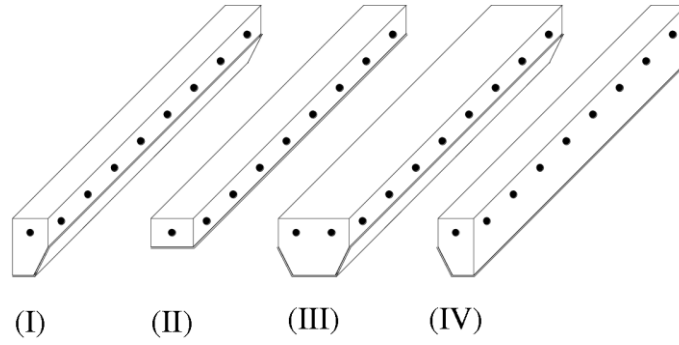

Element types for *cs14*: (I) left.edge.rib; (II) cover; (III) central.rib; (IV) right.edge.rib

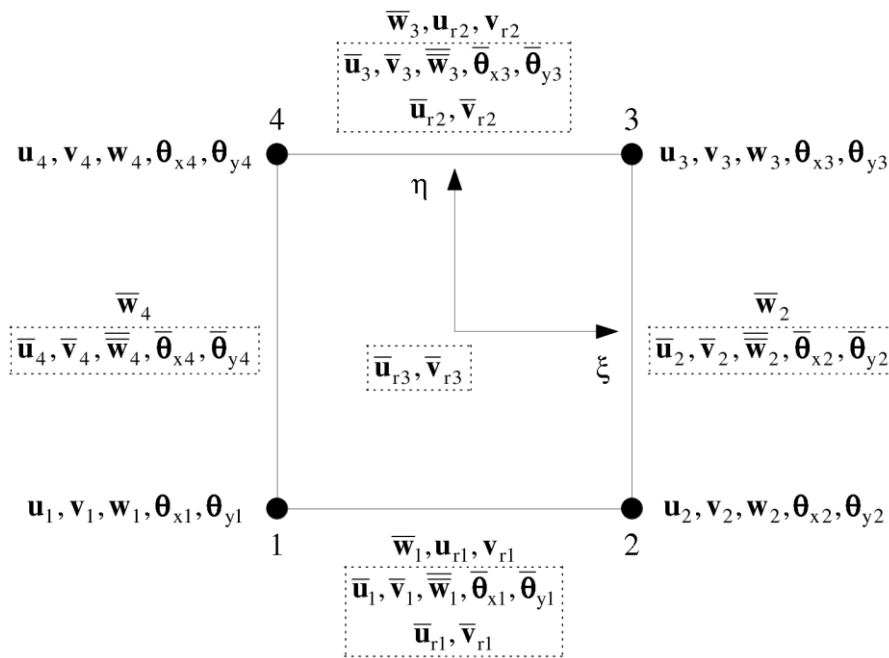

Additional freedoms for element *cs14*

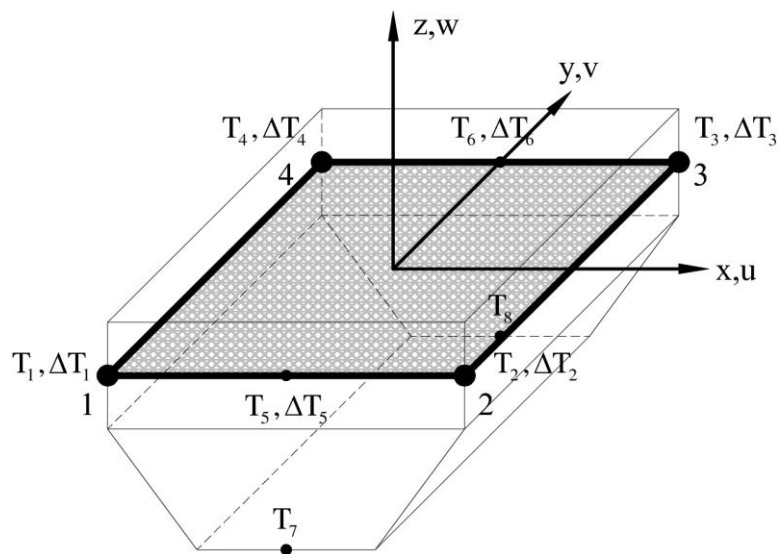

Temperature distribution for *cs14*

Description	Linear cable element with variable length.
Nodes	2
Characteristics	Accounts for large displacements in the small strain range. Allows transfer of material across adjacent connected elements. The element has no bending capacity. Exact integration.
Application	Cable and tension fabric structures. Requires specification of: <code>unstrained.element.dimension(s)</code> <code>coupled.additional.freedom(s)</code>
Restrictions	Only allows use of linear elastic materials. Limited to small strain problems. Starting configuration must be close to equilibrium configuration.
Group header	<code>sec.name</code> : An identifier referring to one of the cross-sections declared in the <code>sections</code> module. Only the elastic axial rigidity EA is used.

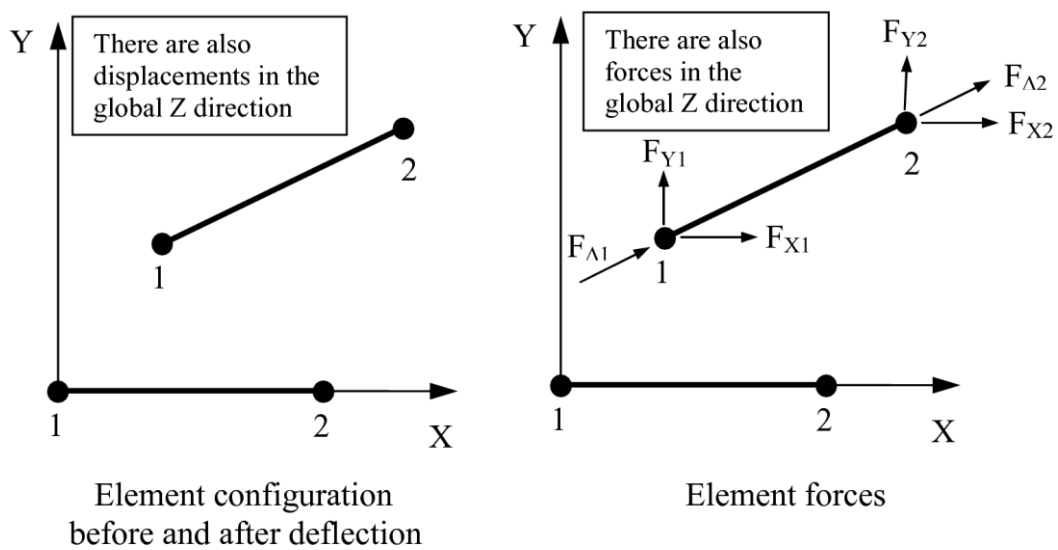

Configuration and global forces for element type *cbl2*

Description	Quadratic cable element with variable length.
Nodes	3
Characteristics	<p>Accounts for large displacements in the small strain range.</p> <p>Allows transfer of material across adjacent connected elements and mid node.</p> <p>The element has no bending capacity.</p> <p>Numerical integration is performed over 3 Gauss points.</p>
Application	<p>Cable and tension fabric structures.</p> <p>Requires specification of:</p> <p style="margin-left: 40px;"><code>unstrained.element.dimension(s)</code></p> <p style="margin-left: 40px;"><code>coupled.additional.freedoms</code></p>
Restrictions	<p>Only allows use of linear elastic materials.</p> <p>Limited to small strain problems.</p>
Group header	<p>sec.name: An identifier referring to one of the cross-sections declared in the sections module. Only the elastic axial rigidity EA is used.</p> <p>sliding.internal: Declaration of whether internal sliding is allowed or prevented.</p> <p>damping.parameter: Specification of damping parameter used in dynamic relaxation solution procedure.</p>

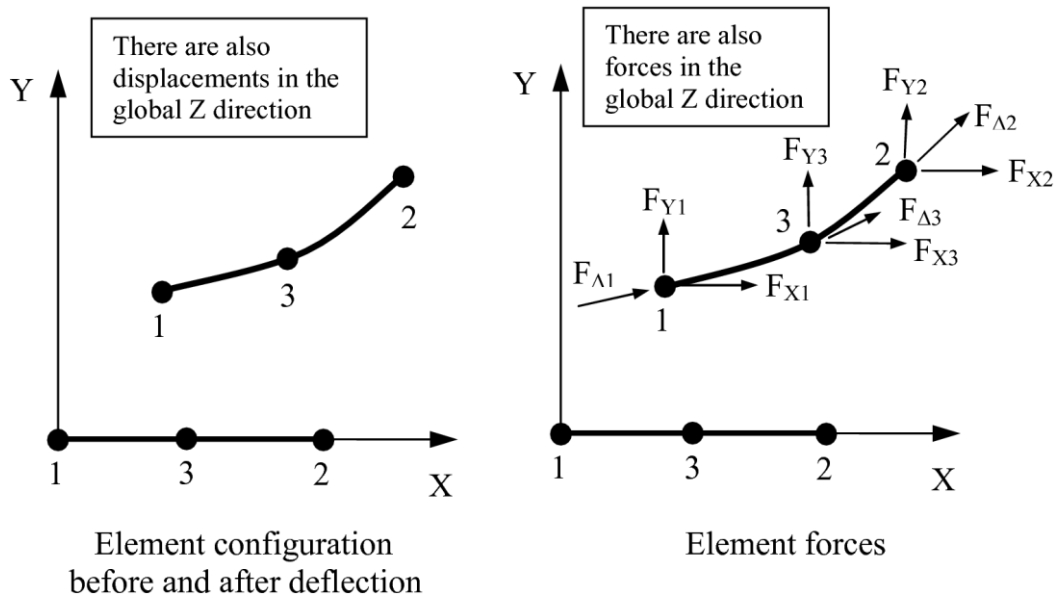

*Configuration and global forces for element type **cbl3***

mem3

Description	Linear membrane element.
Nodes	3
Characteristics	Accounts for large displacements in the small strain range. The element has no bending capacity. Integration is exact.
Application	Tension fabric structures. Requires specification of: <code>unstrained.element.dimension(s)</code>
Restrictions	Only allows use of linear elastic materials. Limited to small strain problems. Starting configuration must be close to equilibrium configuration.
Group header	<code>sec.name</code> : An identifier referring to a cross-section of type thpl declared in the sections module.

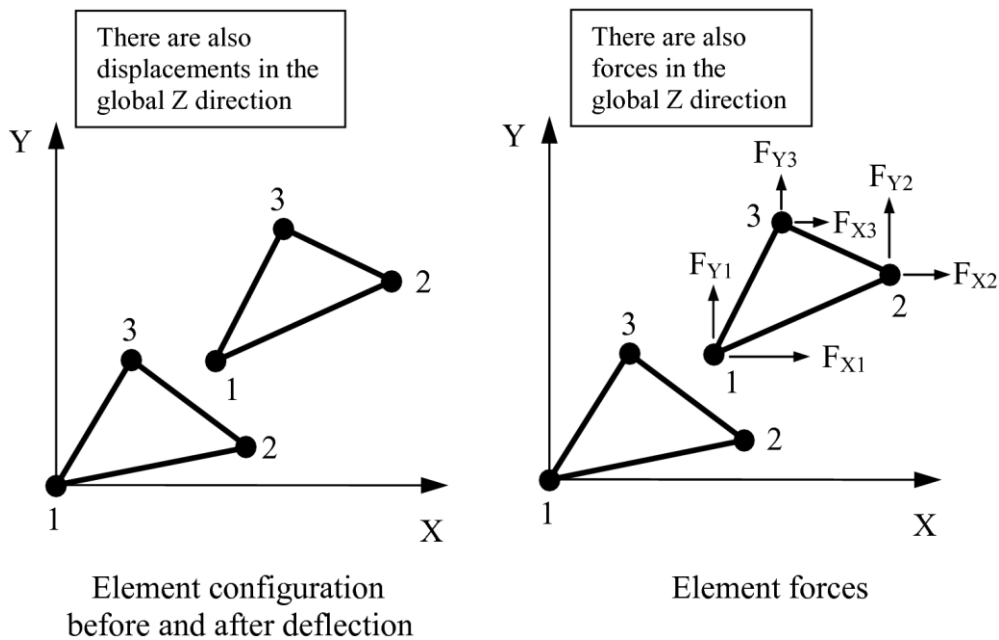

Configuration and global forces for element type mem3

Description	Quadratic membrane element.
Nodes	6
Characteristics	Accounts for large displacements in the small strain range. The element has no bending capacity. Numerical integration performed over four Gauss points.
Application	Tension fabric structures. Requires specification of: <code>unstrained.element.dimension(s)</code>
Restrictions	Allows use advanced fabric material model tfs1 . Limited to small strain problems.
Group header	sec.name : An identifier referring to a cross-section of type thpl declared in the sections module. strain.field : Specifies whether a conforming or assumed strain field is to be used.

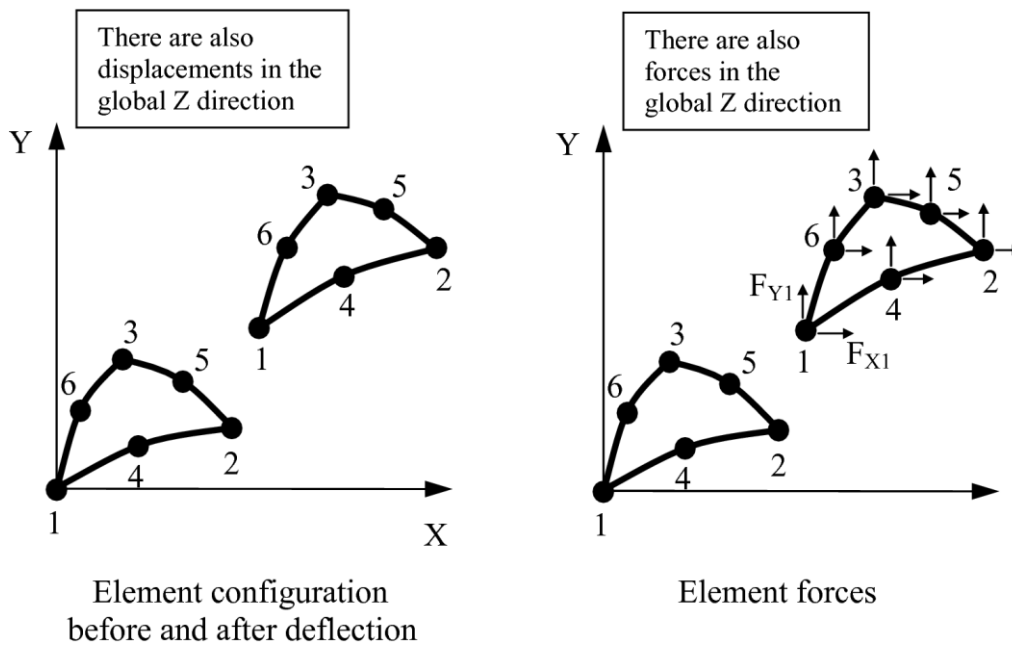

Configuration and global forces for element type *mem6*

<i>Description</i>	bk20 : 20 noded 3D brick element. tt10 : 10 noded 3D tetrahedral element. wd15 : 15 noded 3D wedge element. pd13 : 13 noded 3D pyramid element.
<i>Nodes</i>	20, 10, 15, 13
<i>Characteristics</i>	Models 3D continuum large displacement problems using Green's strain. Applies to static, dynamic and elevated temperature analysis. Allows direct specification of material density and Rayleigh damping parameters for dynamic analysis. Elements can be explicit provided <code>lumped.mass</code> is true (as specified or by default).
<i>Application</i>	Static/dynamic analysis of 3D continuum problems.
<i>Restrictions</i>	Works with material models beth , bnsi , bnsk and tpth .
<i>Group header</i>	mat.name :An identifier referring to one of the materials declared in the materials module. [gauss.points] : optional total number of gauss points; defaults to 27 (ie. 3×3×3) for bk20 . [density] : optional material density used for dynamic analysis; defaults to zero. [damping.parameters] : two optional parameters for mass- and stiffness-proportional Rayleigh damping, respectively; default to the values of <code>mass.damping.parameter</code> and <code>stiffness.damping.parameter</code> specified in the default.parameters module. [lumped.mass] : optional (true false) flag indicating whether mass is to be lumped; defaults to value of <code>lumped.mass</code> in the default.parameters module.

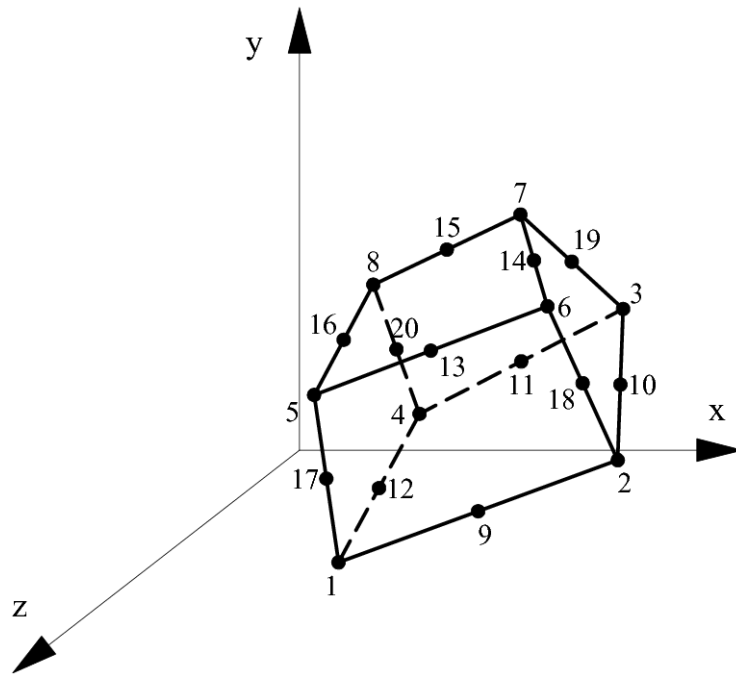

*Nodal ordering for **bk20***

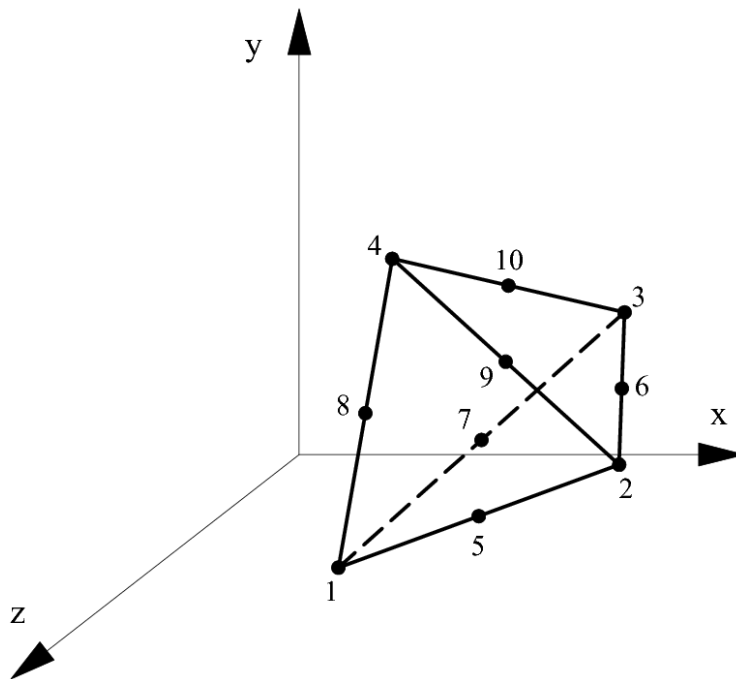

*Nodal ordering for **tt10***

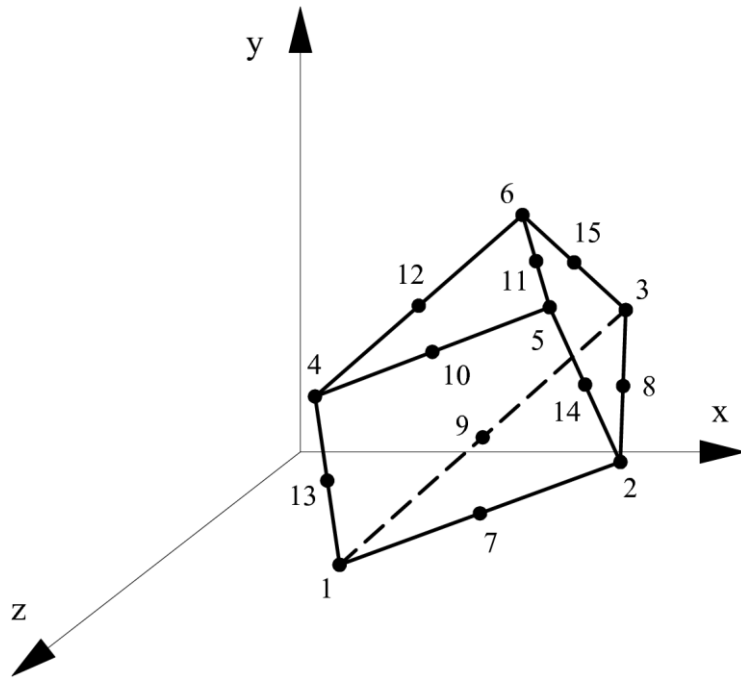

Nodal ordering for wd15

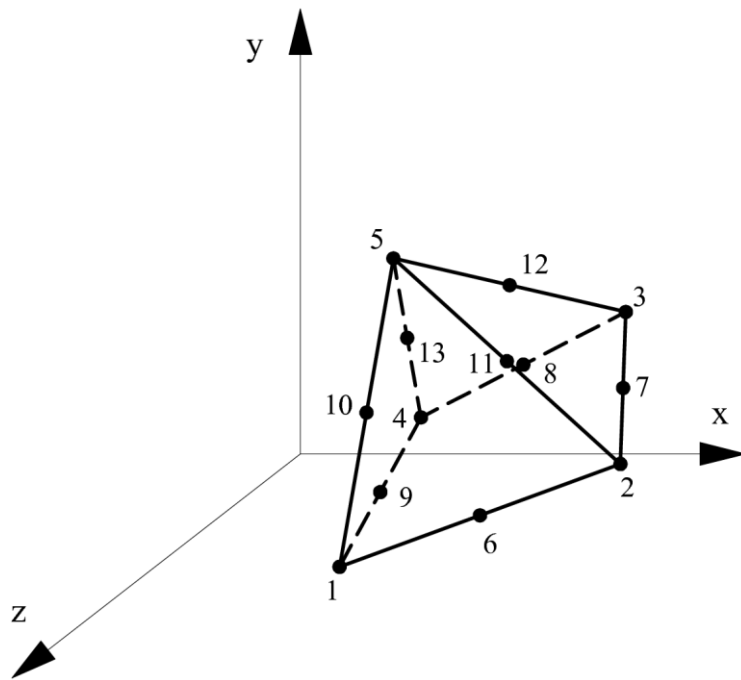

Nodal ordering for pd13

cpl2

Description	2-noded coupling element applicable to different types of analysis (2D, 3D, etc.).
Stiffness parameters	Stiffness parameters for each of the global nodal freedoms which can be numerical (constant stiffness), rigid or contact .
Nodes	2
Characteristics	A numerical stiffness value for a specific global freedom implies linear elastic spring connectivity between the two nodes in this freedom. A rigid value implies fully rigid connectivity, where a contact value implies rigid connectivity if node (2) moves towards node (1) in the negative direction of the freedom and no connectivity otherwise.
Application	All types of analysis.
Restrictions	Global nodal freedoms are coupled independently.
Group header	stiffness.parameters: Defines the stiffness parameters for each of the global freedom directions.

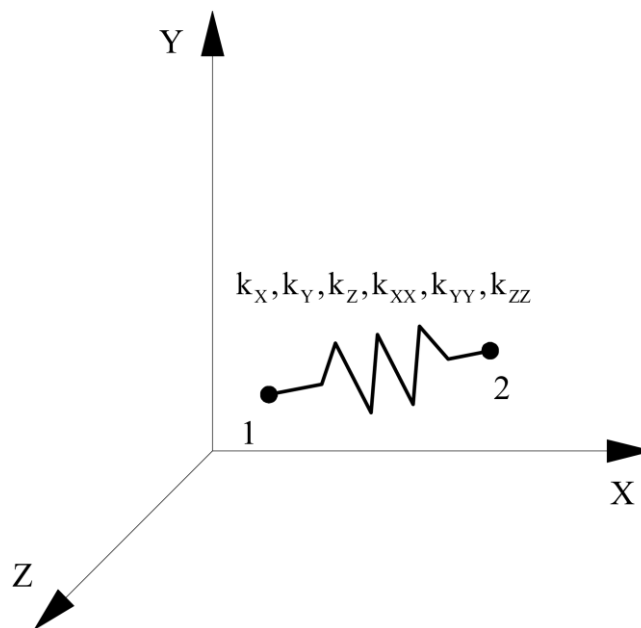

Element type **cpl2** (illustrated for 3D analysis)

Description	Multi-noded spreader element applicable to different types of analysis (2D, 3D, etc.).
Nodes	n -noded: 1 master node and $n-1$ slave (spread) nodes.
Characteristics	Independent constraints/force spreading applied in each of the global translational directions, according to specified ratios.
Application	<p>Spreading of global force applied to master node (1) to the remaining ($n-1$) slave nodes according to specified ratios, allowing time history static/dynamic with prescribed displacement at node (1) while keeping specific force ratios at the remaining ($n-1$) slave nodes.</p> <p>Constraining weighted average of slave node displacements in specific global direction to the corresponding displacement of master node (1) according to the specified ratios.</p> <p>Use in static analysis with proportional loading to control relative displacements of several nodes by applying displacement control to master node; this is particularly useful for problems with a softening post-cracking response, enabling the direct control of crack opening using standard displacement control (where arc-length control may suffer convergence problems).</p>
Restrictions	Only global translations and global forces can be constrained and spread, respectively.
Group header	<p>direction: global translational direction(s) of constraint and force spreading (e.g. x+z). Note that if master node (1) is not connected to other elements, its rotational and unconstrained translational freedoms should be restrained.</p> <p>[equilibrating]: optional (true false) flag, (default = true), indicating whether the element should be self-equilibrating, in which case the ratios.of.spread are automatically normalised to a unit total. This is only possible if the original total is not relatively small or zero. If the element cannot be equilibrating, then the force transmitted at the master node (1) is not equilibrated by the forces at the remaining nodes; this case is mainly useful in displacement control of master node (1) under proportional loading so as to control relative displacements of the slave nodes, in which case no loading should be applied at the master node.</p> <p>spread.nodes: number of slave/spread nodes (ie. $n-1$).</p> <p>ratios.of.spread: ($n-1$) ratios of spread for the respective slave nodes. These are normalised to a unit total for the self-equilibrating element case; if the original total is relatively</p>

small or zero, then normalisation is ignored, and the element cannot be self-equilibrating.

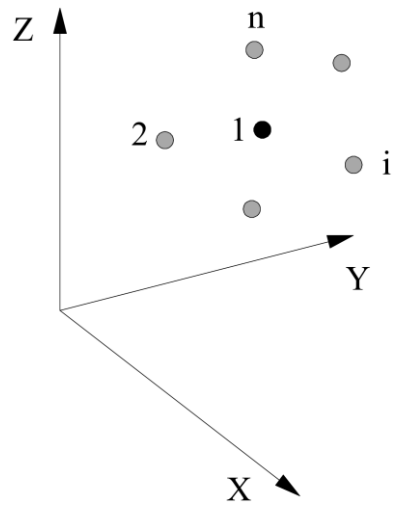

Configuration of element type sprd

Chapter 7. DATA SYNTAX

7.1 Introduction

A header-oriented syntax is utilized in ADAPTIC data files. Data modules are identified by means of unique headers, and only the first four characters in the header key words are necessary. However, if more than four characters of a key word are employed, the ADAPTIC data input module checks for the consistency of all characters.

Names or numbers employed, for example, as identifiers for elements or nodes can be up to 8 character long. However, if this number is exceeded only the first 8 characters are considered.

The following symbols are used for describing the ADAPTIC data syntax. Note that these symbols are used in the rest of this manual only for delivering information, and they must not be used within an ADAPTIC data file.

<u>Symbol</u>	<u>Description</u>
(.....)	Parantheses used to include a list of items.
	Exclusive OR. For example (2d 3d) is equivalent to a single entry which can be either 2d or 3d.
[.....]	Brackets used to include optional item(s). For example [z] means that entry z is optional.
< entry >	Specifies the entry type. For example < integer > indicates an integer data entry.
^	Indicates that the entries for the previous key word in the header can be defined by assignment outside the header line. For example,

```
mat.name    model^    properties
indicates that the following two data modules,
mat.name    model    properties
m1          stl1    210e9 300e6 0.01
and,
model = stl1
mat.name    properties
m1          210e9 300e6 0.01
are equivalent.
```

7.2 General Facilities

This sections describes general facilities which are available with all data modules, unless indicated otherwise.

7.2.1 Continuation

The ampersand (**&**) symbol can be used to continue data entry on the next line.

7.2.2 Comments

Comments can be added anywhere in the data file using the hash (#) symbol. All entries following a (#) on the current line are ignored.

7.2.3 Incrementation

The automatic incrementation facility can be used with some data modules. This is indicated where applicable. The general syntax is given below:

f	< entry {1} >	< entry {n} >
r	< inc. {1,1} >	< inc. {n,1} > < rep. {1} >
r [<range{2}>]	< inc. {1,2} >	< inc. {n,2} > < rep. {2} >
r [<range{m}>]	< inc. {1,m} >	< inc. {n,m} > < rep. {m} >

<entry {i}> ith entry on the first data line used for generation.

<range {j}> Range of previously generated lines to be used for further incrementation.

Syntax of <range {j}> is ([<first {j}>] : [<last {j}>] [: <step {j}>]), for example 2:7 or 4:10:2.

<inc. {i,j}> The increment to be used in the generation of the ith entries.

If <entry {i}> is a character string then <inc{i,j}> must be a dash (-).

<rep. {j}> The number of times each line in the range <range {j}> is incremented.

Notes The defaults for optional arguments are:

<range {j}> = **1**:(total number of lines generated so far)

<first {j}> = **1**

<last{j}> = total number of lines generated so far

<step {j}> = **1**

7.3 Input Modules

This sections describes the input modules available within ADAPTIC.

7.3.1 Analysis

This module specifies the analysis type.

```
analysis ( 2d | 3d ) ( eigenvalue | dynamic [explicit] | static )
```

2d	Two dimensional analysis.
3d	Three dimensional analysis.
eigenvalue	Eigenvalue analysis.
dynamic	Dynamic analysis.
explicit	Explicit time-integration for dynamic analysis.
static	Static analysis.

Notes Dynamic analysis is performed using implicit time-integration, unless the **explicit** option is used.

7.3.2 Default.parameters

This module specifies some default parameters.

```
default.parameters  
  
mass.damping.parameter = < real >  
stiffness.damping.parameter = < real >  
normals.coincidence.angle = < real >  
  
lumped.mass = (true|false)
```

<code>mass.damping.parameter</code>	Parameter used to specify mass-proportional damping, without the need for damping elements. Applies to mass elements cnm2 , lnm2 , cbm2 , cnm3 , lnm3 , cbm3 and bk20 .
<code>stiffness.damping.parameter</code>	Parameter used to specify stiffness-proportional damping, without the need for damping elements. Applies to elements bk20 .
<code>normals.coincidence.angle</code>	An angle tolerance which determines whether two normals from adjacent elements are coincident; defaults to $\cos^{-1}(0.9999)$.
<code>lumped.mass</code>	Indicates whether the mass of applicable elements is to be lumped; defaults to true with explicit dynamic analysis and false otherwise.

Notes

7.3.3 Materials

This module specifies material identifiers referring to a particular model and model properties.

<code>materials</code>		
<code>mat.name</code>	<code>model^</code>	<code>properties</code>

<code>mat.name</code>	A material identifier referring to the specified model and properties. The material name can be any alphanumeric string.
<code>model</code>	The material model used. The model should be one of those specified in Chapter 3 .
<code>properties</code>	The material model properties. The number of properties must be as indicated in Chapter 3 for the corresponding model.

Notes

7.3.4 Sections

This module specifies [cross-section](#) identifiers referring to a section type, constituent materials and section dimensions.

<code>sections</code>			
<code>sec.name</code>	<code>type^</code>	<code>mat.name^</code>	<code>dimensions</code>

<code>sec.name</code>	The name of the section which has the given properties. The name can be any alphanumeric string.
<code>type</code>	The section type. This must be one of the available types given in Chapter 5 .
<code>mat.name</code>	Specifies the material(s) used. The specified entry(s) should be one of the material identifiers declared in the <code>materials</code> module.
<code>dimensions</code>	Dimensions of the section. The number of dimension must be as defined in Chapter 5 for the corresponding section type.

Notes

7.3.5 Patterns

This module defines subdivision patterns utilised in automatic mesh refinement. The specified ratios indicate the number of potential subelements and their relative lengths.

<code>patterns</code>	
<code>pat.name</code>	<code>ratios</code>

`pat.name`

A pattern identifier.

`ratios`

Integer values denoting relative lengths of zones where inelasticity is checked. The number of integers implicitly defines the number of zones.

Notes

7.3.6 Groups

This module defines properties for [element](#) groups. The number and nature of group properties depend on the type of elements for which the group is being established.

groups

type.of.element = < element type > _ **grp.name** = <group header>

7.3.7 Structural.nodal.coordinates

This module defines coordinates of structural nodes.

<code>structural.nodal.coordinates</code>			
<code>nod.name</code>	<code>x^</code>	<code>y^</code>	<code>[z^]</code>

`nod.name` A node identifier which can be any alphanumeric string.

`x, y, z` Global nodal coordinates.

Notes `z` is only required for 3D analysis.

Incrementation can be used with this module.

7.3.8 Non.structural.nodal.coordinates

This module defines coordinates of structural nodes.

<code>non.structural.nodal.coordinates</code>			
<code>nod.name</code>	<code>x^</code>	<code>y^</code>	<code>[z^]</code>

`nod.name` A node identifier which can be any alphanumeric string.

`x, y, z` Global nodal coordinates.

Notes `z` is only required for 3D analysis.

Incrementation can be used with this module.

7.3.9 Element.connectivity

This module defines the connectivity of elements in a mesh configuration.

<code>elm.name</code>	<code>grp.name^</code>	<code>nod.name (s)</code>
-----------------------	------------------------	---------------------------

<code>elm.name</code>	An element identifier which can be any alphanumeric string.
<code>grp.name</code>	An identifier referring to one of the groups declared in the <code>groups</code> module.
<code>nod.name (s)</code>	The element end nodes defined in the <code>structural.nodal.coordinates</code> or <code>non.structural.nodal.coordinates</code> modules.

Notes Incrementation can be used with this module.

7.3.10 Imperfections

This module specifies imperfection levels within elements of specific types.

imperfections	
elm.name	values[^]

elm.name	The element which has the specified imperfection values.
-----------------	--

values	The imperfection values for the element.
---------------	--

Notes

7.3.11 Coupled.additional.freedoms

This module specifies coupled additional freedoms for elements of specific types.

coupled.additional.freedoms

elm.name(s) [**freedom.sets**]

elm.name(s) A pair of elements for which additional freedoms are to be coupled.

freedom.sets Specification of freedom sets to be coupled.

Notes **freedom.sets** are used for coupling the additional freedoms of partition super-elements.

7.3.12 Restraints

This module defines nodal restraints.

restraints	
[nod.name	direction ^]
[elm.name	freedom ^]

nod.name	The node to be restrained.
direction	Specifies the direction in which the defined node is restrained. = x displacement along global X-axis. = y displacement along global Y-axis. = z displacement along global Z-axis. = rx rotation about global X-axis. = ry rotation about global Y-axis. = rz rotation about global Z-axis.
elm.name	The element to be restrained.
freedom	The element additional freedom to be restrained. = fa## (e.g. fa5 and fa12 for freedoms 5 and 12); or = wp# (e.g. wp1 and wp2 for warping freedoms).

Notes In two dimensional analysis, only **x**, **y** and **rz** directions can be specified.
Multiple freedoms can be specified by one entry (e.g. x+y+ry indicates restraints in the three directions x, y and ry).
Incrementation can be used with this module.

7.3.13 Conditions

This module specifies the conditions which govern the termination of the automatic control phase under a proportional static loading regime. These conditions are expressed in terms of limits on the load factor or displacements at specific freedoms.

```
conditions
( ( lf.cnd.name limits ) |
  ( disp.cnd.name nod.name direction limits ) )
```

<code>lf.cnd.name</code>	Used for the load factor condition option, with the entry representing the condition identifier.
<code>limits</code>	Specifies the minimum and maximum limits.
<code>disp.cnd.name</code>	Used for the displacement condition option, with the entry representing the condition identifier.
<code>nod.name</code>	The node name for which the displacement condition applies.
<code>direction</code>	The direction for which the displacement condition applies. = x displacement along global X-axis. = y displacement along global Y-axis. = z displacement along global Z-axis. = rx rotation about global X-axis. = ry rotation about global Y-axis. = rz rotation about global Z-axis.

Notes Multiple direction specification is not allowed in this module.

This module is only applicable when using `proportional.loads` in the `applied.loading` module.

7.3.14 Linear.curves

This module specifies piecewise linear load curves for dynamic or time history loading.

```
linear.curves
start.time = <real>
crv.name = <name>
  ( (time load.factor) |
    (file = <file name> ]
      [delay = <real> ]
      [first.line = <integer> ]
      [last.line = <integer> ]
      [format = <format specification> ] )
```

start.time	Specifies the start time at which all load curves have a zero value. This entry must be less than the first TIME entry of all load curves
crv.name	A curve identifier.
time	Time or pseudo-time column of entries.
load.factor	Load factor column entries corresponding to the time entries.
file	The name of the file in which the load curve is stored. This option can be used if the load curve is stored in a file.
delay	The time delay from the start time before the load curve is applied. Default = 0
first.line	The line number in file corresponding to the first entry of the load curve. Default = 1
last.line	The line number in file corresponding to the last entry of the load curve. Default = <end of file>
format	A FORTRAN format specification by which the load curve entries are read from file . Default = <free format>

Notes Load factors of all load curves are taken as zero at the start time.

The time entries of a load curve recalled from a **file** are shifted by the value of **delay** which must always be positive. The load factor for such curves is zero between **start.time** and (**start.time** + **delay**).

This module is only applicable when using **time.history.loads** or **dynamic.loads** defined in the **applied.loading** module.

7.3.15 Integration.scheme

This module specifies the time integration scheme for dynamic analysis and its parameters.

```
integration.scheme
( scheme = newmark
  [ beta = < real > ]
  [ gamma = < real > ] ) |
( scheme = hilber.hughes.taylor
  [ alpha = < real > ]
  [ beta = < real > ]
  [ gamma = < real > ] )
```

scheme	The time integration scheme.
alpha	HHT α parameter ($>-1/3$). Default = 0.0 (Newmark)
beta	Newmark/HHT β parameter. Default = $0.25(1-\alpha)^2$
gamma	Newmark/HTT γ parameter. Default = $0.5-\alpha$

Notes This module is only applicable for dynamic analysis defined by the existence of `dynamic.loads` in the `applied.loading` module.

7.3.16 Applied.loading

This module specifies the type and the value of the applied loads.

```
applied.loading
[ initial.loads
  ( nod.name direction^ type^ value^ ) |
  ( elm.name type^ value^ ) ]
( ( proportional.loads
  nod.name direction^ type^ value^ ) |
  ( time.history.loads
  ( nod.name direction^ type^ crv.name^ value^ ) |
  ( elm.name type^ crv.name^ value^ ) ) |
  ( dynamic.loads
  ( nod.name direction^ type^ crv.name^ value^ ) |
  ( elm.name type^ crv.name^ value^ ) ) )
```

<code>initial.loads</code>	These are static loads that are applied prior to any variable load. They can be forces or prescribed displacements applied at nodes in the global directions.
<code>proportional.loads</code>	These are static loads having proportional variation. The magnitude of a load at any step is given by the product of its nominal value and the current load factor. Proportional loads may be forces or prescribed displacements applied at nodes in the global directions.
<code>time.history.loads</code>	These are static loads varying according to different load curves in the pseudo-time domain. The magnitude of a load at any given pseudo-time is given by the product of its nominal value and the load factor obtained from its load curve at that pseudo-time. Time history loads may be forces or prescribed displacements applied at nodes in the global directions.
<code>dynamic.loads</code>	These are dynamic loads varying according to different load curves in the real time domain. The magnitude of a load at any given time is given by the product of its nominal value and the load factor obtained from its load curve at that time. Dynamic loads can be forces or

	accelerations applied at the nodes in the global directions.
nod.name	The node at which the load is applied.
direction	The direction of the applied load: = x displacement along global X-axis. = y displacement along global Y-axis. = z displacement along global Z-axis. = rx rotation about global X-axis. = ry rotation about global Y-axis. = rz rotation about global Z-axis.
type	Defines the type of the applied load = (force f) applied force. = (displacement d) applied displacement. = (velocity v) applied velocity. = (acceleration a) applied acceleration. = element specific keyword for element loads.
elm.name	The element subjected to loading.
value	Nominal value of the applied load.
crv.name	The load curve defining the variation of dynamic or time history loads. The load curve must be declared in the <code>linear.curves</code> module.

Notes

`proportional.loads`, `time.history.loads` and `dynamic.loads` cannot be used in the same analysis.

`initial.loads` can be used in static or dynamic analysis, but the module is optional. The load **type** can either be **force** or **displacement** for both static and dynamic analysis. In dynamic analysis only, **velocity** and **acceleration** can be used to indicate initial conditions, but these are only applicable to dynamic freedoms (i.e. those associated with mass/damping elements or support excitation).

`proportional.loads` or `time.history.loads` must be used in static analysis, for which the load **type** can either be **force** or **displacement**.

`dynamic.loads` must be used in dynamic analysis, for which the load **type** can either be **force** or **acceleration**.

Element loads cannot be applied as `proportional.loads`.

7.3.17 Equilibrium.stages

This module defines stages of time intervals at which structural equilibrium is established.

<code>equilibrium.stages</code>	
<code>end.of.stage</code>	<code>steps</code>

`end.of.stage` Defines the end time of a stage.

`steps` The number of steps within a stage.

Notes

The time-step size for a stage is equal to the difference between the end time of the current stage and that of the previous stage divided by the number of steps of the current stage. For the first stage, the time step size is equal to the difference between the end of the first stage and the `start.time` defined in `linear.curves`.

This module is only applicable when using `time.history.loads` or `dynamic.loads` defined in the `applied.loading` module.

7.3.18 Phases

This module defines the control phases used to trace the load deflection curve for proportional loading. Three types of control are available: load, displacement and automatic control.

```

phases
( ( load.control
    increment      path      steps ) |
  ( displacement.control
    [( nod.name | elm.name )] direction increment path steps ) |
  ( automatic.control
    type      path      cnd.name ) )

```

load.control	Represents the load-control option.
displacement.control	Represents the displacement-control option.
automatic.control	Represents the automatic displacement-control option.
increment	Specifies the increment in the load factor for load.control , the increment of displacement for displacement.control , or the increment of arc length.
path	Specifies the sign of the increment <ul style="list-style-type: none"> (continue c) = follow the previous loading path. (reverse r) = unload relative to the previous loading path (keep k) = keep the sign of the increment as specified. This cannot be used for arc-length control.
steps	The number of steps used to apply the increment.
(nod.name elm.name)	The name of the node or element used for displacement control. Omission of this implies arc-length control. Note that arc-length control cannot be used for the first phase.
direction	The global direction in which the displacement control will be applied.
type	The automatic.control type:

(**nod.control** | **elm.control** | **arc.length.control**)

(**translation** | **rotation** | x+y+z).

The direction specification $x+y+z$ is used only for **arc.length.control**, and can represent any combination of the available translational freedoms (x, y and/or z).

cond.name

The name of the stopping condition used in the automatic-control option. The specified condition should be declared in the **conditions** module.

Notes

The [path](#) entry, always be **keep** for the first phase.

automatic.control can not be the first phase.

7.3.19 Iterative.strategy

This module specifies the iterative strategy applied during a load or a time step.

iterative.strategy		
[number.of.iterations	=	< integer >]
[initial.reformations	=	< integer >]
[step.reduction	=	< integer >]
[divergence.iteration	=	< integer >]
[scaled.iterations	=	< integer >]
[tol.relax.level	=	< integer >]
[maximum.convergence	=	< real >]
[arc.flow.iteration	=	< integer >]

number.of.iterations	The maximum number of iterations performed for each increment. Default = 10
initial.reformations	The number of initial reformations of the tangent stiffness matrix within an increment. Default = 10
step.reduction	The step reduction factor used when convergence is not achieved. Default = 5
divergence.iteration	The iteration after which divergence checks are performed. Default = 6
scaled.iterations	Number of iterations (> 2) after divergence over which the iterative displacement corrections are gradually scaled from zero to their full value. Default = 1 (scaling off)
tol.relax.level	Step-reduction level (0 to 3) from and above which tolerance relaxation (between tolerance and maximum.tolerance) is allowed. Default = 0
maximum.convergence	The maximum convergence value allowed for any iteration Default = 1000

`arc.flow.iteration` Iteration number after which the normal flow method is applied with arc-length control.

Default = `number.of.iterations`

Notes

Using a number of `initial.reformations` equal to the `number.of.iterations` is equivalent to the Newton- Raphson strategy.

Using a number of `initial.reformations` equal to 0 is equivalent to the modified Newton- Raphson strategy.

The solution is considered to be diverging if after the `divergence.iteration` the convergence of the current iteration is greater than that of the previous iteration. This check is not applied during the `scaled.iterations` stage and for a number of subsequent iterations equal to `divergence.iteration`, or if a relaxed solution within `maximum.tolerance` has been found. Scaling of iterative displacement corrections is applied after divergence if the remaining number of iterations exceeds `scaled.iterations`; this technique can be used to overcome convergence oscillations.

The increment is reduced by the `step.reduction` factor if convergence (full or relaxed) is not achieved, divergence occurs or `maximum.convergence` is exceeded. The original increment can be reduced for up to three levels.

The normal flow option for arc-length control can improve convergence characteristics, but does not guarantee that the displacement increments correspond exactly to the specified arc length.

7.3.20 Convergence.criteria

This module defines convergence criteria for the iterative procedures. The convergence criteria is based either on the out-of-balance norm or the maximum iterative displacement increment.

convergence.criteria		
tolerance	=	< real >
(force.ref	=	< real >
moment.ref	=	< real >)
(displacement.ref	=	< real >
rotation.ref	=	< real >)
(work.ref	=	< real >
[maximum.tolerance	=	< real >]

tolerance	The required convergence tolerance for each load or time step.
force.ref	The force reference value used in calculating the convergence. Applicable to convergence criteria based on the out-of-balance norm.
moment.ref	The moment reference value used in calculating the convergence. Applicable to convergence criteria based on the out-of-balance norm.
displacement.ref	The displacement reference value used in calculating the convergence. Applicable to convergence criteria based on the maximum iterative displacement increment.
rotation.ref	The rotation reference value used in calculating the convergence. Applicable to convergence criteria based on the maximum iterative displacement increment.
work.ref	The work reference value used in calculating the convergence. Applicable to convergence criteria based on the energy norm.
maximum.tolerance	The maximum tolerance to which a solution may be relaxed to if the specified tolerance could not be satisfied with the iterative.strategy . This is used in conjunction with tol.relax.level .

Default = 0

Notes

A `tolerance` and `maximum.tolerance` equal to zero is equivalent to an iterative procedure in which a fixed `number.of.iterations` is performed for each load or time step without consideration of convergence.

7.3.21 Output

This module specifies the frequency of numerical output.

output

frequency < integer > [**stress**] [**local.displacements** |
no.local.displacements] **eigenvalue.interval** < integer >

frequency

Provides the frequency of the numerical output.

= 0 all equilibrium steps including step reduction levels.

= 1 all equilibrium steps without step reduction levels.

= n output every "n" equilibrium steps.

stress

Specified if element stresses are required. Applicable only to specific [element types](#).

[**no.**] **local.displacements**

Indicates whether the local displacements of elements are output, which is true by default.

eigenvalue.interval

Indicates the output interval for eigenvalue analysis during dynamic analysis.

7.3.22 Lanczos.eigenvalue

This module specifies the number of required eigenvalues and the range of natural frequencies of interest. The Lanczos eigenvalue algorithm is utilized.

```
lanczos.eigenvalue  
number.of eigenvalues = < integer >  
steps = < integer >  
w.min = < real >  
w.max = < real >  
shift = < real >  
  
[ starting.vector  
  nod.name      direction^      value^ ]
```

number.of eigenvalues	The number of required eigenvalues.
steps	The number of Lanczos steps to converge to the eigenvectors.
w.min	Minimum natural frequency of interest.
w.max	Maximum natural frequency of interest.
shift	The frequency shift during the solution of the eigenvalue problem.
starting.vector	Initial vector used by the Lanczos algorithm to derive eigenvectors.
nod.name	Node name considered in the starting vector.
direction	The global direction which is given the specified values.
value	The value of the entry in the starting vector corresponding to the nod.name in the global direction .

Notes

The number of steps must be less or equal to the total number of freedoms for the structure.

w.min, **w.max** and **shift** are in rd/sec.

shift must be between **w.min** and **w.max**.

A random starting vector is generated if the starting vector module is not specified.

Chapter 8. POST-PROCESSING

8.1 Start-Up

After the analysis has been *completed*, a post-processing application may be started to study the structural response graphically. Two graphics post-processing applications are available:

- 1) **ADAPTIC_graphs** for plotting X-Y graphs. This is activated as follows

```
{prompt} adaptic -g [filename[.dat|.svg]]
```

- 2) **ADAPTIC_shapes** for plotting deflected shapes. This is activated as follows

```
{prompt} adaptic -s [filename[.dat|.svs]]
```

The above applications are discussed separately in the following sections.

8.2 ADAPTIC_graphs

8.2.1 General Facilities

The main items of the graphics region in the ADAPTIC_graphs application are shown in Figure 8.2.1. The mouse buttons can be used to manipulate the appearance, size and position of each of the components, as discussed below.

Moving

Each of the items may be moved using the left mouse button with a single click to activate moving followed by a click and drag to move to the desired position.

Resizing

This facility only applies to the "Graph Area" item. It can be performed using the right mouse button with a single click to activate resizing followed by a click and drag of the bottom right corner to the desired position.

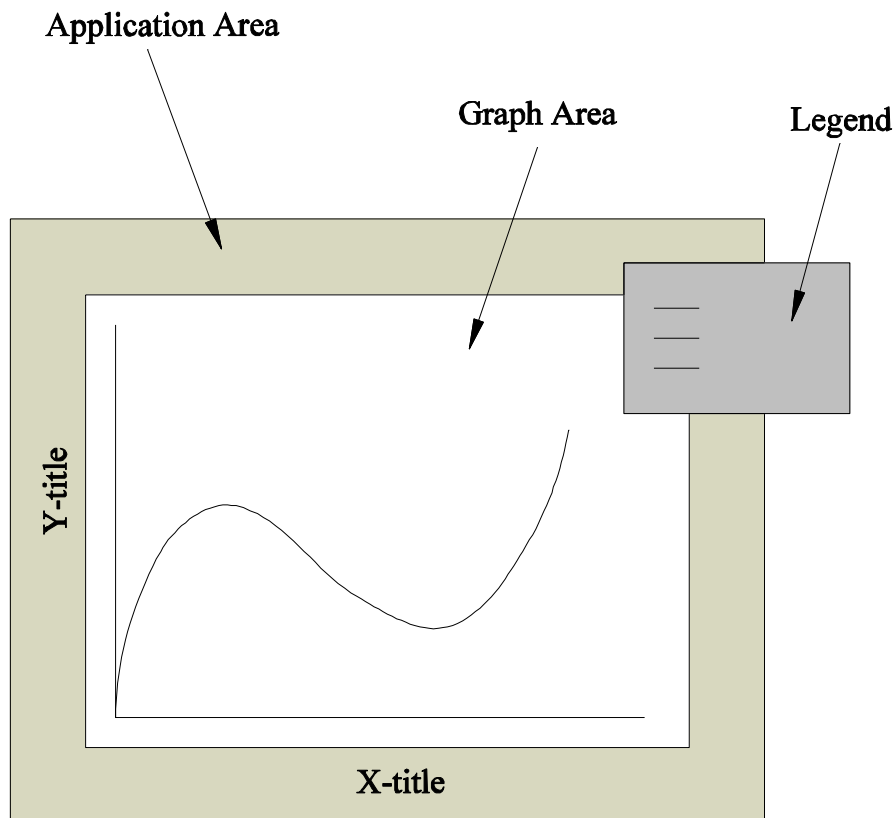

Figure 8.2.1. Graphics region of ADAPTIC_graphs application

8.2.2 File

This menu option offers the following facilities discussed with reference to the initiating buttons.

Data File

This invokes a form which allows the selection of the data file corresponding to the analysis that has been performed. Select the file *filename.dat* from the list of files in the directory where the analysis has been performed, where *filename* stands for the file identifier (e.g. *one_storey*).

Save

This button provides the means for storing plot information in a plot file for later retrieval. This is quite important for storing a permanent description of the plot, so that future modification can be performed with relative ease. Save files for the ADAPTIC_graphs application are automatically given a ".svg" extension.

Retrieve

This button retrieves ".svg" plot files that have been previously saved.

Print/Export

This button allows i) the output of the plot description to an Encapsulated PostScript (EPS) file, which can be imported into word processing applications, or ii) the export of numerical data as X-Y columns within a text file, which can be used for further processing and plotting in spreadsheet applications.

Exit

This allows the ADAPTIC_graphs application to be terminated. Before exiting, make sure you have saved your plot file, if necessary.

8.2.3 Graphs

Three facilities can be accessed using this menu option, as discussed below.

New Curve

This allows the selection of X and Y entities for a new line graph. After selecting the entities, described hereafter, the Done button must be pressed followed by the Plot button for displaying the new line graph.

TIME/LOAD FACTORS: Allows the selection of time or load factor, depending on the type of analysis, as well as CPU time and output number for plotting. The output numbers are explicitly indicated for the various steps of the nonlinear analysis in the output file *filename.out*.

FORCES AT PRESCRIBED FREEDOMS: Allows the selection of forces at restrained or prescribed freedoms. The latter are defined as any freedom subject to a displacement or time-history acceleration load.

NODAL ENTITIES: This covers nodal displacements, velocities and accelerations. The last two should only be requested for dynamic analysis.

ELEMENT ENTITIES: This covers i) local element entities (e.g. element forces and local displacements which depend on the element type), and ii) stresses and strains, the availability of which depend on the element type.

ENERGY GROUPS: This allows the selection of energy components determined for pre-defined energy groups.

ARITHMETIC EXPRESSIONS: This is a general utility which allows the combination of entities corresponding to previous line graphs in arithmetic expressions. The following definitions are valid combinations, referring to the Y coordinate of line graph 1, the X coordinate of line graph 3 and the Y coordinate of line graph 2:

Y1-2-X3/6

Y2**2-Y1*X3

Y2-Y1

Such expressions should be typed in the dialogue box.

One application of this utility is for generating entities representing relative displacements rather than absolute nodal displacements.

Delete Curves

This allows previous line graphs to be deleted. This may be desirable if a curve is no longer required, especially if it was originally intended for providing X and Y coordinates to be manipulated by the ARITHMETIC EXPRESSIONS utility described above.

Clear All

This facility clears the contents of the current plot. This allows the construction of a new plot.

8.2.4 Customize

This option facilitates the customisation of the graph characteristics.

Fonts

This allows the modification of the font name, size and style for the axes titles, axes labels and legend text.

Axes

This facility can be used to modify the axes attributes, including thickness, colour, etc. It also allows individual axes to be modified in terms of minimum and maximum values, step size, scaling factor, etc.

Lines

Each line graph can be customised using this facility with regard to thickness, style, colour, the use of points, activation/de-activation, the output range of interest, the corresponding legend text, etc.

Legend

The legend can be customised with regard to visibility as well as the number of legend columns.

8.3 ADAPTIC_shapes

8.3.1 General Facilities

The main components of the ADAPTIC_shapes application are shown in Figure 8.3.1. The functionality of each component is described hereafter.

Graphics Display Area

This is the main graphics area where the structure is displayed. Each of the three mouse buttons has a *click-and-drag* functionality, which is modified by the Shift, and which depend on whether normal or perspective [view](#) is selected.

For normal view:

- Lef button: rotate about planar axes, origin centred in structure.
- Lef button + Shift: rotate about out-of-plane axis.
- Right button: zoom in.
- Right button + Shift: zoom out.
- Middle button: move.
- Middle button + Shift: pan.

For prespective view:

- Lef button: rotate camera about planar axes, origin centred at focal point.
- Lef button + Shift: rotate camera about out-of-plane axis.
- Right button: move camera forwards/backwards.
- Right button + Shift: zoom camera in/out.
- Middle button: pan camera in plane.
- Middle button + Shift: move scene in plane.

The three mouse buttons can also be combined with the Control key to select partitions in partitioned modelling.

- Lef button + Control: select parent partition.
- Right button + Control: select nearest first-level child partition.
- Middle button + Control: select root partition.

Orientation Tool

This tool displays the orientation of the global structural reference axes in the current view. The four arrow buttons can be used to change this orientation by i) selecting a global axis for incremental rotation, ii) specifying the increment of rotation, iii) applying positive rotation increments, and/or iv) applying negative rotation increments.

A single click with the mouse buttons on the orientation display area has the following functionality:

- Lef button: controlled customisation of current [view](#).
- Right button: turn on/off axes orientation in the Graphics Display Area.

View Indicator

This displays the current view number (1, 2 or 3). The presence of (+) indicates that the current view is a subsequent modification of a stored view, whereas (-) indicates that the

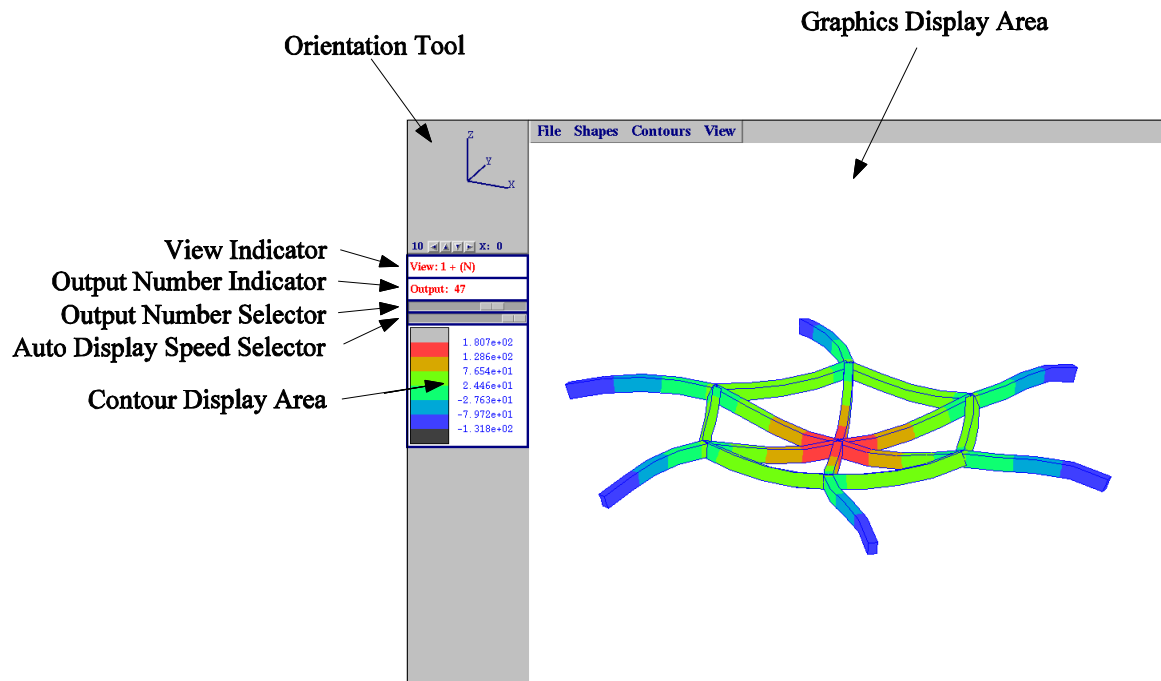

Figure 8.3.1. Components of ADAPTIC_shapes application

current view is a precursor to a stored view. Furthermore, (N) indicates a normal view, whereas (P) indicates a perspective view.

Output Number Indicator

This displays the current output number, as well as the corresponding eigenvalue mode if any, in view. For example, “Output: 3” refers to the actual deflected shape in output number 3, “Output: 5 [M2]” refers to mode 2 of output number 5 with auto display/slider control given to varying the output number, while “Output: [5] M2” refers to the same mode and output number with auto display/slider control given to varying the mode number.

A single click with the left mouse button enables specification of output number and eigenvalue mode.

Output Number Selector

This allows output number selection using a slider, which is more convenient for a quick browse through the deflected shapes.

Auto Display Speed Selector

This enable the speed of automatic display for deflected shapes to be controlled using a slider.

Contour Display Area

This area displays the contour colours and scale, and is activated by the [General Settings](#) button.

A single click with the mouse buttons on the contour display area has the following functionality:

- Lef button: customisation of [contours](#).
- Right button: turn on/off contour information in the Graphics Display Area.

8.3.2 File

This menu option offers the following facilities discussed with reference to the initiating buttons.

Data File

This allows the selection of the data filename, provided the application is started on the command line without a filename specification, i.e.:

```
{prompt} adaptic -s
```

Save

This button provides the means for storing plot information in a plot file for later retrieval. This is quite important for storing a permanent description of the plot, so that future modification can be performed with relative ease. Save files for the ADAPTIC_shapes application are automatically given a ".svs" extension.

Retrieve

This button retrieves ".svs" plot files that have been previously saved.

Print

This button allows the output of the plot description to an Encapsulated PostScript (EPS) file, which can be imported into word processing applications.

Movie

Where supported, this button allows the capture of [Auto Display](#) as a ".m1v" movie.

General Settings

This button enables/disables the display of i) the initial shape alongside the deflected shape, ii) node and element labels, iii) contours, and iv) customisation of auto display/slider control.

The initial shape and labels are enabled by default for the undeflected configuration.

Control can be given to [Auto Display](#) and the [Output Number Selector \(Slider\)](#) to vary either the output number for a specific mode or the mode number for a specific output number. Also, a increment of output/mode numbers can be specified for Auto Display.

Exit

This allows the ADAPTIC_shapes application to be terminated. Before exiting, make sure you have saved your plot file, if necessary.

8.3.3 Shapes

This menu option offers the following facilities discussed with reference to the initiating buttons.

Output Number

This specifies the output and mode numbers to be displayed.

Output number 0 refers to the initial undeflected configuration, with other numbers referring to various equilibrium states obtained during nonlinear analysis.

For a specific output number, mode number 0 refers to the actual deflected shape of the equilibrium state, while other mode numbers refer to eigenvalue modes if any have been obtained for this equilibrium state.

Auto Display

This enables an animation of the structural response or the eigenvalue modes through sequential automatic display of deflected shapes/modes.

Animation control can be given in the [General Settings](#) over varying the output numbers for a specific mode (0 for the deflected shape) or the mode numbers for a specific output number (0 for the initial configuration).

The speed of animation is controlled by the [Auto Display Speed Selector](#). The animation can be interrupted with a single mouse click with any button anywhere within the application window.

Customize

This allows the display of various element types to be customised, mainly in terms of i) basic or full plotting, ii) range of element to be excluded from view, iii) plotting divisions over element, iv) line colour, v) fill colour, vi) line thickness and vii) appearance of nodal and element labels. For partitioned modelling, the customisation can be applied at the level of the selected partition with/without child partitions or alternatively for all partitions. The customisation can also be applied selectively for individual element types or uniformly for all element types, where the latter offers the option of propagating specific customisations to all types at various partition levels, except for the element range which is only propagated over the currently selected partition.

Select Partition

This is used in partitioned modelling to select a new current partition. This can be specified 1) as the parent of the current partition, 2) by local name in the current partition, or 3) by rank (i.e. process rank as reflected in the "#nnn" extension to the base file name).

8.3.4 Contours

This menu option offers the following facilities discussed with reference to the initiating buttons.

Select Entities

This allows the selection of entities associated with specific element types for contour plotting. Note that this facility may not be available for some element types. Furthermore, the plotting of contours in the Graphics Display Area is controlled by the specification under [General Settings](#).

Customize

This enables the specification of the number of contours, the associated colours and the corresponding numerical range, whether manual or automatic. An automatic contour range is established from the maximum and minimum values of the entities to be plotted.

8.3.5 View

This menu option offers the following facilities discussed with reference to the initiating buttons.

Scale

This specifies the displacement/mode scale to be used.

Two independent scale values can be specified for plotting the deflected shape (i.e. mode = 0) and the eigenvalue modes (i.e. mode > 0).

For large displacement analysis, the scale for the deflected shape (mode = 0) is normally specified as (1).

For eigenvalue analysis, a large scale ($\gg 1$) may need to be specified to distinguish the mode shape from the initial undeflected shape.

Different scales can be specified for the global X, Y and Z displacement components (e.g. 1 for X and 0 for Y & Z to consider only the X displacements), though identical scales are commonly used for realistic deflected shapes.

Select

This allows the selection of any of the three stored views in addition to the previous view. By default, the three views correspond to normal views of the i) X-Y, ii) X-Z and iii) Y-Z planes.

Store

This allows the storage of the current view into one of the three available views.

Customize

This enables customisation of the current view, including i) axes orientation, ii) zoom centre, iii) zoom scale, and iv) normal/perspective specification.

Chapter 9. EXAMPLES

9.1 Space dome subject to vertical apex load

The dome space structure shown in the figure has been widely considered in the verification of nonlinear analysis methods for 3D frames. The aim here is to be able to predict the lowest buckling mode of the dome.

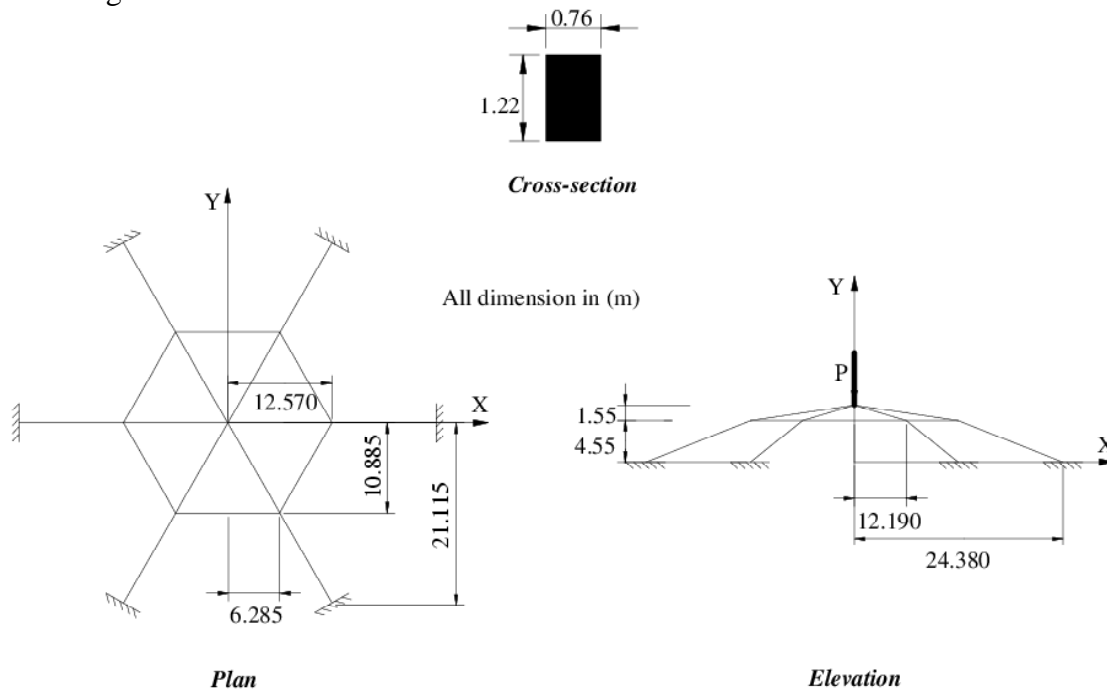

figure 9.1. Configuration of space dome subject to vertical apex load.

In order to illustrate the behaviour of the structure under a increasing load, here is going to be use ADAPTIC, which has the capability of predicting the large displacements static and dynamic behaviour of elastic and inelastic plane and space frames.

9.1.1 Data file

```
#
analysis 3d static \(a\)
#
materials \(b\)
  mat.name      model      properties
  mat1          beth       20690 0.172 0.0
sections \(c\)
  type = rss
  sec.name      mat.name    dimensions
  sect1         mat1       0.76 1.22
#
groups \(d\)
type = gel3
  grp.name      sec.name
  gp1          sect1
#
structural \(e\)
  nod.n        x          y          z
  1            0          0          0
  11           6.286     -10.886   -1.551
  12           12.572    0.002    -1.552
  13           6.288     10.888   -1.553
  14           -6.287    10.887   -1.552
  15           -12.573   0.003    -1.553
  16           -6.286   -10.886   -1.551
  21           12.190   -21.115   -6.10
  22           24.380    0         -6.10
  23           12.190    21.115   -6.10
  24           -12.190   21.115   -6.10
  25           -24.380   0         -6.10
  26           -12.190   -21.115   -6.10
#
non.structural \(f\)
  nod.name     x          y          z
  1011         6.286     -10.886   10
  1012         12.572    0.002    10
  1013         6.288     10.888   10
  1014         -6.287    10.887   10
  1015         -12.573   0.003    10
  1016         -6.286   -10.886   10
#
restraints \(g\)
  direction = x+y+z+rx+ry+rz
  nod.name
f    21
r    1    5
#
element.connectivity \(h\)
  grp.name = gp1
  elm.name  nod.name
f    1      21    11    1011
r    1      1    1      1    5
#
f    11     11    1    1011
r    1      1    0      1    5
#
f    21     11    12    1011
r    1      1    1      1    4
```

```

    26      16   11  1016
#
applied.loading \(i\)
  proportional
  type = force
    nod.name      direction  value
      1           z          -1
#
phases \(j\)
load.control
  increment      path      steps
    70           k         14
displacement.control
  nod.name      dire      increment  path  steps
    1           rz        -0.24    k    30
    1           z         -3       k    20
#
iterative.strategy \(k\)
  number = 10
  initial.reformations = 10
  step.reduction = 10
  divergence.iteration = 8
  maximum.convergence = 1e+8
#
convergence.criteria \(l\)
  tolerance = 0.1e-5
  force.ref = 1
  moment.ref = 1
#
output \(m\)
frequency 1 local
#
end

```

9.1.2 Structural behaviour

The nonlinear analysis is undertaken using one element per member, the response shown in the figure illustrate the ability of this method to predict the lowest buckling mode and to trace the associated post buckling path when an imperfect dome is considered.

Here is been obtained how the vertical apex deflection varies while the load increases.

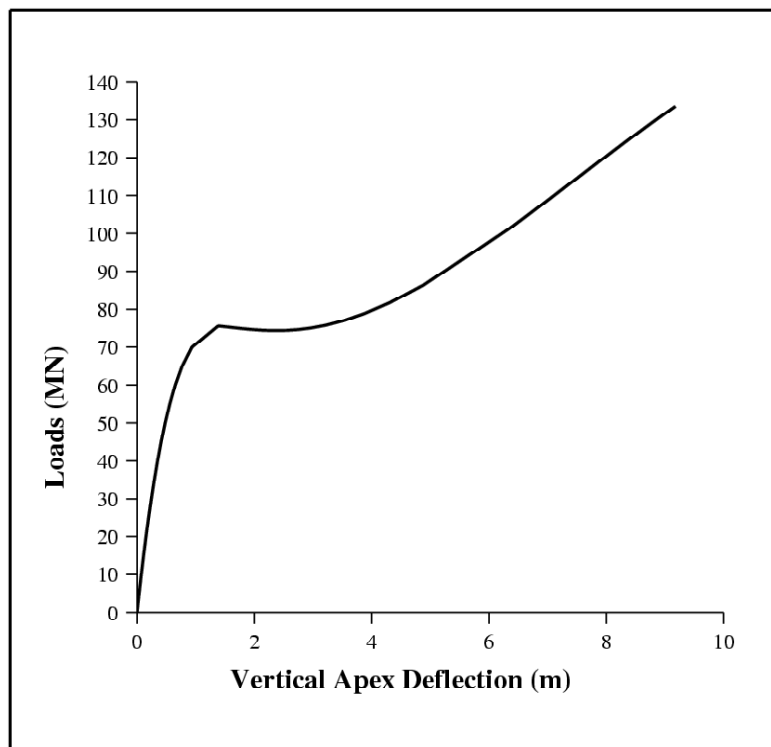

figure 9.1.2.a. Response of space dome structure.

As is shown in the figure there is a first path where the displacements of the structure are almost proportional to the load, but when is arrived to a certain value of load, the displacement are nonlinear, and they increase more than the load.

It is evident that the introduction of small imperfections activates the lowest buckling mode, which involves a planar rotational mode, like is shown in the *figure*. In the absence of these imperfections the dome deflects fully symmetric about the dome apex (*papers*).

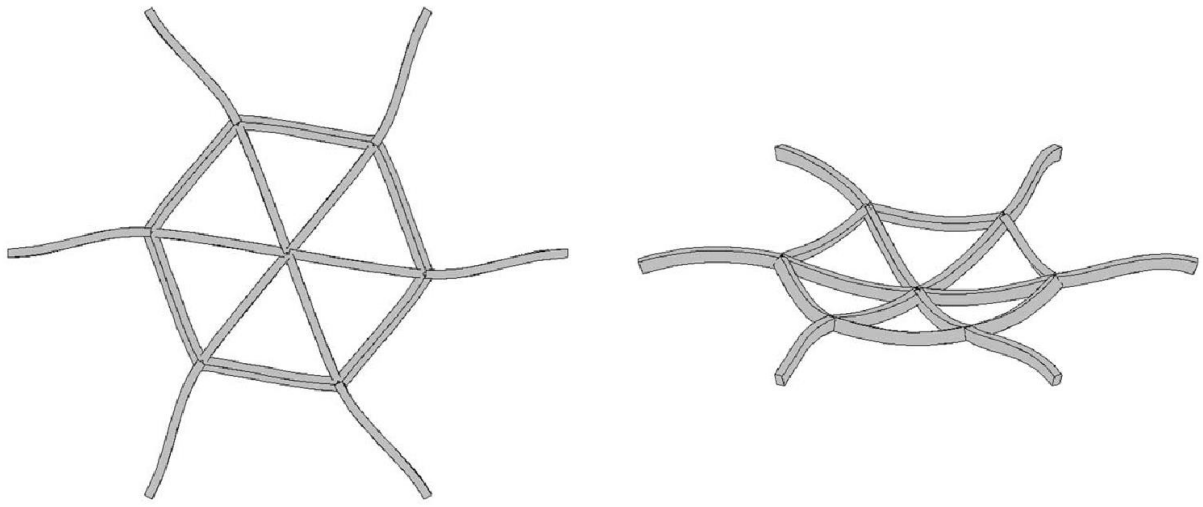

figure 9.1.2.b.Final deflected shape of space imperfect dome.

9.1.3 Output file

ADAPTIC also give an output file, where can be found the way that the program calculates the structure.

```

          ELEMENT ASSEMBLY ORDER
----->>>> ----->>>> ----->>>> ----->>>> ----->>>> ----->>>> ----->>>> ----->>>>
1         11         21         26         2         12         22         13
14        15        16         6         25         3         23         4
24         5

```

```

MAXIMUM FRONT: (NODAL = 5) - (ADDITIONAL FREEDOMS = 0)
+++++

```

```

          V A R I A B L E      L O A D I N G
          +++++

```

```

PHASE NUMBER = 1
TYPE = LOAD CONTROL
INCREMENT FACTOR =0.700000E+02
NUMBER OF STEPS = 14

```

OUTPUT	VARIABLE LOAD FACTOR	LEVEL	CONV.-NORM	ITERATIONS
1	0.50000000E+01	0	0.546E-10	2
2	0.10000000E+02	0	0.883E-10	2
3	0.15000000E+02	0	0.162E-09	2
4	0.20000000E+02	0	0.293E-09	2
5	0.25000000E+02	0	0.568E-09	2
6	0.30000000E+02	0	0.118E-08	2
7	0.35000000E+02	0	0.266E-08	2
8	0.40000000E+02	0	0.659E-08	2
9	0.45000000E+02	0	0.185E-07	2
10	0.50000000E+02	0	0.613E-07	2
11	0.55000000E+02	0	0.255E-06	2
12	0.60000000E+02	0	0.860E-11	3
13	0.65000000E+02	0	0.918E-11	3
14	0.70000000E+02	0	0.325E-08	3

```

PHASE NUMBER = 2
NODAL DISPLACEMENT CONTROL
GLOBAL DIRECTION = RZ
CONTROLLED NODE = 1

```

```

DISPLACEMENT INCREMENT =-.240000E+00
NUMBER OF STEPS = 30

```

OUTPUT ITERATIONS	DISPLACEMENT INCREMENT	VARIABLE LOAD FACTOR	LEVEL	CONV.-NORM	
0	-.80000000E-03	0.74819797E+02	1	0.188E-07	8
0	-.80000000E-03	0.75170596E+02	1	0.871E-11	3
0	-.80000000E-03	0.75299433E+02	1	0.604E-06	2
0	-.80000000E-03	0.75366635E+02	1	0.150E-07	2
0	-.80000000E-03	0.75407861E+02	1	0.891E-09	2
0	-.80000000E-03	0.75435665E+02	1	0.921E-10	2

0	-.80000000E-03	0.75455610E+02	1	0.155E-10	2
0	-.80000000E-03	0.75470539E+02	1	0.650E-11	2
0	-.80000000E-03	0.75482060E+02	1	0.838E-11	2
15	-.80000000E-03	0.75491151E+02	1	0.800E-11	2
16	-.80000000E-02	0.75524591E+02	0	0.594E-07	2
17	-.80000000E-02	0.75521580E+02	0	0.938E-07	2
18	-.80000000E-02	0.75503625E+02	0	0.108E-06	2
19	-.80000000E-02	0.75474865E+02	0	0.130E-06	2
20	-.80000000E-02	0.75436480E+02	0	0.161E-06	2
21	-.80000000E-02	0.75388739E+02	0	0.203E-06	2
22	-.80000000E-02	0.75331551E+02	0	0.260E-06	2
23	-.80000000E-02	0.75264686E+02	0	0.338E-06	2
24	-.80000000E-02	0.75187920E+02	0	0.446E-06	2
25	-.80000000E-02	0.75101171E+02	0	0.599E-06	2
26	-.80000000E-02	0.75004682E+02	0	0.820E-06	2
27	-.80000000E-02	0.74899266E+02	0	0.694E-11	3
28	-.80000000E-02	0.74786682E+02	0	0.629E-11	3
29	-.80000000E-02	0.74670196E+02	0	0.106E-10	3
30	-.80000000E-02	0.74555445E+02	0	0.885E-11	3
31	-.80000000E-02	0.74451780E+02	0	0.843E-11	3
32	-.80000000E-02	0.74374309E+02	0	0.462E-11	3
33	-.80000000E-02	0.74346913E+02	0	0.996E-11	3
34	-.80000000E-02	0.74406363E+02	0	0.492E-11	3
35	-.80000000E-02	0.74607289E+02	0	0.875E-11	3
36	-.80000000E-02	0.75027175E+02	0	0.149E-10	3
37	-.80000000E-02	0.75770907E+02	0	0.351E-10	3
38	-.80000000E-02	0.76977822E+02	0	0.792E-10	3
39	-.80000000E-02	0.78843610E+02	0	0.182E-09	3
40	-.80000000E-02	0.81695491E+02	0	0.723E-09	3
41	-.80000000E-02	0.86304315E+02	0	0.138E-07	3
0	-.80000000E-03	0.86954218E+02	1	0.269E-09	2
0	-.80000000E-03	0.87640899E+02	1	0.566E-09	2
0	-.80000000E-03	0.88387322E+02	1	0.911E-09	2
0	-.80000000E-03	0.89206621E+02	1	0.155E-08	2
0	-.80000000E-03	0.90117991E+02	1	0.273E-08	2
0	-.80000000E-03	0.91151485E+02	1	0.496E-08	2
0	-.80000000E-03	0.92359318E+02	1	0.273E-07	2
0	-.80000000E-03	0.93849297E+02	1	0.670E-06	2
0	-.80000000E-03	0.95940853E+02	1	0.391E-10	3
0	-.80000000E-04	0.96260563E+02	2	0.129E-09	2
0	-.80000000E-04	0.96572169E+02	2	0.103E-08	2
0	-.80000000E-04	0.96917884E+02	2	0.345E-08	2
0	-.80000000E-04	0.97312732E+02	2	0.186E-07	2
0	-.80000000E-04	0.97785290E+02	2	0.182E-06	2
0	-.80000000E-04	0.98411526E+02	2	0.918E-11	3
0	-.80000000E-05	0.98520476E+02	3	0.146E-10	2
0	-.80000000E-05	0.98609176E+02	3	0.365E-09	2
0	-.80000000E-05	0.98703536E+02	3	0.417E-09	2
0	-.80000000E-05	0.98806745E+02	3	0.109E-08	2
0	-.80000000E-05	0.98921952E+02	3	0.363E-08	2
0	-.80000000E-05	0.99054545E+02	3	0.171E-07	2
0	-.80000000E-05	0.99215707E+02	3	0.145E-06	2
0	-.80000000E-05	0.99438530E+02	3	0.636E-10	3

Phase (2) terminated
+++++

PHASE NUMBER = 3
NODAL DISPLACEMENT CONTROL
GLOBAL DIRECTION = Z
CONTROLLED NODE = 1

DISPLACEMENT INCREMENT =-.300000E+01
NUMBER OF STEPS = 20

OUTPUT ITERATIONS	DISPLACEMENT INCREMENT	VARIABLE LOAD FACTOR	LEVEL	CONV.-NORM	
42	-.15000000E+00	0.10110066E+03	0	0.224E-08	2
43	-.15000000E+00	0.10278682E+03	0	0.230E-08	2
44	-.15000000E+00	0.10449112E+03	0	0.233E-08	2
45	-.15000000E+00	0.10621060E+03	0	0.238E-08	2
46	-.15000000E+00	0.10794230E+03	0	0.247E-08	2
47	-.15000000E+00	0.10968333E+03	0	0.258E-08	2
48	-.15000000E+00	0.11143082E+03	0	0.273E-08	2
49	-.15000000E+00	0.11318196E+03	0	0.293E-08	2
50	-.15000000E+00	0.11493396E+03	0	0.318E-08	2
51	-.15000000E+00	0.11668410E+03	0	0.352E-08	2
52	-.15000000E+00	0.11842972E+03	0	0.395E-08	2
53	-.15000000E+00	0.12016827E+03	0	0.452E-08	2
54	-.15000000E+00	0.12189727E+03	0	0.527E-08	2
55	-.15000000E+00	0.12361439E+03	0	0.630E-08	2
56	-.15000000E+00	0.12531749E+03	0	0.772E-08	2
57	-.15000000E+00	0.12700463E+03	0	0.972E-08	2
58	-.15000000E+00	0.12867421E+03	0	0.127E-07	2
59	-.15000000E+00	0.13032502E+03	0	0.171E-07	2
60	-.15000000E+00	0.13195645E+03	0	0.240E-07	2
61	-.15000000E+00	0.13356868E+03	0	0.355E-07	2

9.2 K-frame subject to vertical load

The k-frame, shown in the figure, is subjected to an end force **P**, where load application in the middle of the upper frame. The buckling forces for this frame were also obtained with ADAPTIC, where the following values were reported using 4 elements.

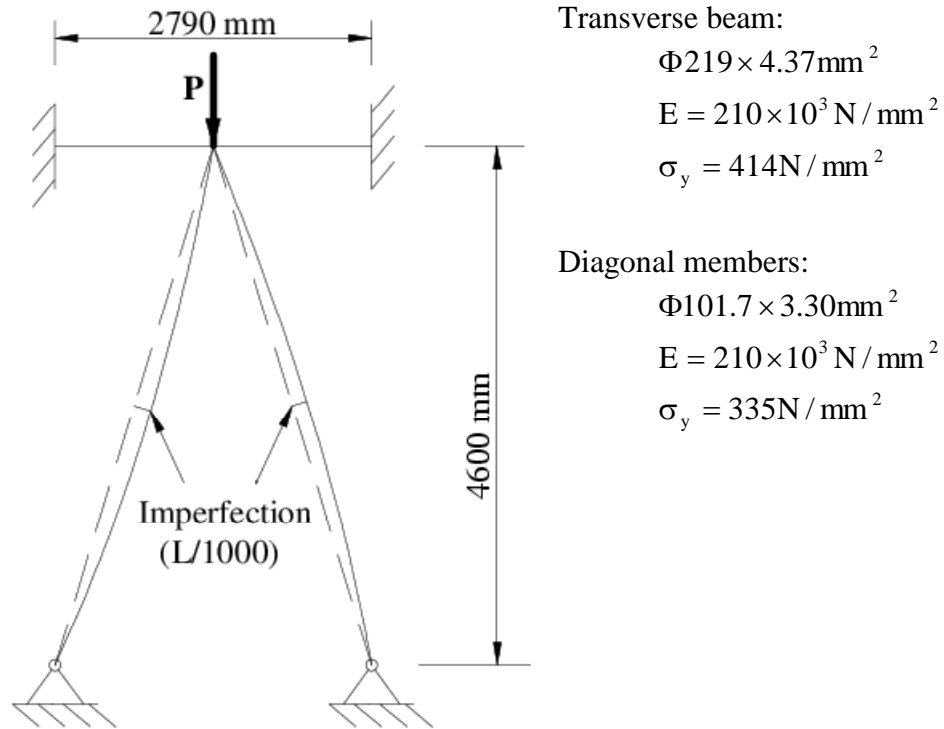

figure 9.2.a Geometric configuration of K-frame.

9.2.1 Data file

```
#
analysis 2d statics \(a\)
#
materials
  mat.name   model   properties
  mat1      st11   0.210e6 0.335e3 0.00 \(b\)
  mat2      st11   0.210e6 0.414e3 0.00
#
sections \(c\)
  type = chs
  sec.name   mat.name   dimensions
  sect1      mat1       101.7  3.30
  sect2      mat2       219.0  4.37
#
groups \(d\)
type = qph2
  grp.name   sec.name   subdivision
  grp1       sect1      t
  grp2       sect2      f
#
structural.nodal \(e\)
  nod.n      x          y
  f 1        0000.0     0000.0
  r 1        2790.0     0000.0 1
  f 3        0000.0     4600.0
  r 1        1395.0     0000.0 2
#
restraints \(g\)
  nod.name   direction
  f 1        x+y
  r 1        -      1
  f 3        x+y+rz
  r 2        -      1
#
element.connectivity \(h\)
  elm.name   grp.name   nod.name
  f 1        grp1      1 4
  r 1        -         3 -2 1
  f 3        grp2      3 4
  r 1        -         1 1 1
#
imperfection \(n\)
  elm.name   values
  1          -3.6 -4.8 -3.6
  2          3.6  4.8  3.6
#
applied.loading \(i\)
  proportional
  nod.name   direction   type   value
  4          y          force  -0.100e+7
#
condition \(o\)
  disp.cnd.name nod.name   direction   limits
  1            4          y          -300.0 0.0
#
phases \(j\)
load.control
  increment   path   steps
```

```

1.0          k          25
automatic.control
  type              path  cnd.name
  nodal translation  c      1
#use default iterative strategy
#iterative.strategy (k)
#number = 10
#initial.reformations = 10
#step.reduction = 10
#divergence.iteration = 6
#maximum.convergence = 0.1e5
#
convergence.criteria (l)
  tolerance = 0.1e-5
  force = 0.5e+6
  moment = 0.1e+8
#
output (m)
frequency 0
#
end

```

Note The following picture shows the names that have been given to the nodes and elements in the data file.

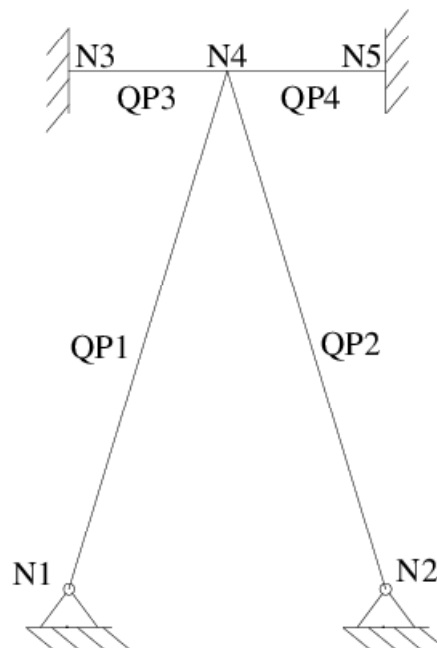

figure 9.2.1 Nodes and elements of the K-frame.

9.2.2 Structural behaviour

The nonlinear analysis is undertaken using one element per member, the response shown in the figure 9.2.2a shows the static response of K-frame.

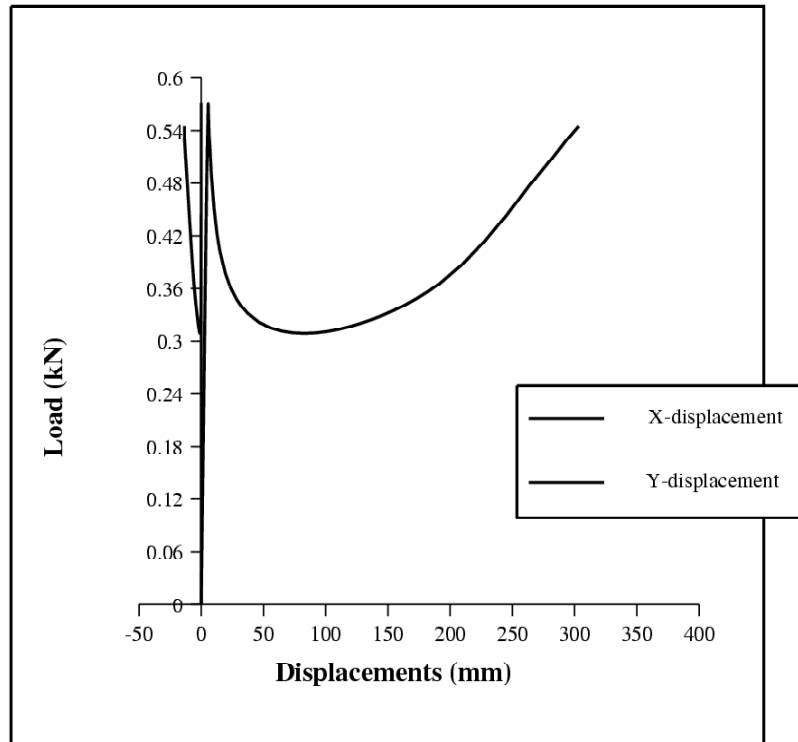

figure 9.2.2a Static response of K-frame

Here is shown the ability of this method to predict the lowest buckling mode and to trace the associated post-buckling path when an imperfect K-frame is considered.

The figure illustrates that the higher displacements of the structure are in the X-direction of the frame. When is arrived to a certain value of load, the displacement increase with fewer loads, and with minor load you can obtain higher displacements.

The following figure illustrates the response of modelling K-frame with the plastic-hinge approach.

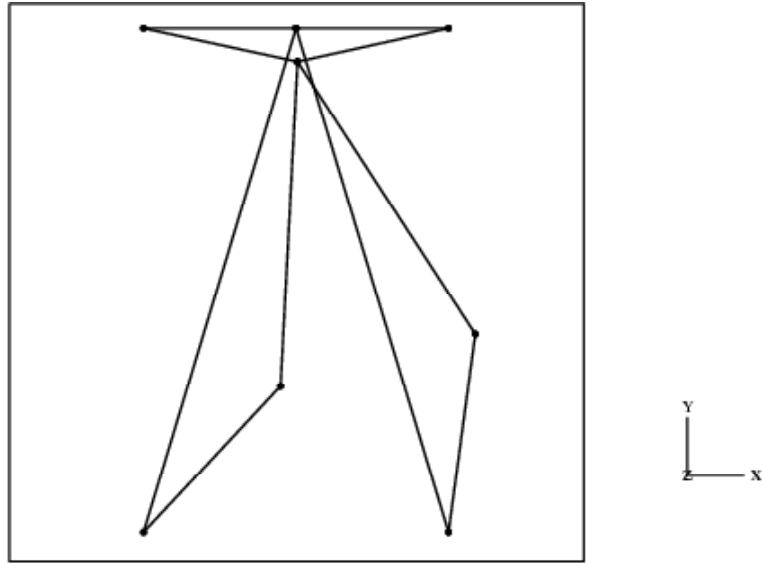

Figure 9.2.2b Deformed shape modelling with the plastic-hinge approach.

It is evident that the introduction of small imperfections activates the lowest buckling mode, which involves a deflection shape, like is shown in the figure. In the absence of these imperfections the K-frame deflects fully symmetric about symmetry axes.

9.2.3 Output file

This is the output file given by ADAPTIC.

```

----->>>> ----->>>> ----->>>> ----->>>> ----->>>> ----->>>> ----->>>>
1           2           3           4
MAXIMUM FRONT: (NODAL =      3) - (ADDITIONAL FREEDOMS =      0)
+++++++

```

VARIABLE LOADING
+++++++

PHASE NUMBER = 1
TYPE = LOAD CONTROL
INCREMENT FACTOR = 0.100000E+01
NUMBER OF STEPS = 25

OUTPUT	VARIABLE LOAD FACTOR	LEVEL	CONV.-NORM	ITERATIONS
1	0.40000000E-01	0	0.155E-07	1
2	0.80000000E-01	0	0.242E-07	1
3	0.12000000E+00	0	0.390E-07	1
4	0.16000000E+00	0	0.651E-07	1
5	0.20000000E+00	0	0.114E-06	1
6	0.24000000E+00	0	0.209E-06	1
7	0.28000000E+00	0	0.407E-06	1
8	0.32000000E+00	0	0.854E-06	1
9	0.36000000E+00	0	0.135E-11	2
10	0.40000000E+00	0	0.913E-11	2
11	0.44000000E+00	0	0.725E-10	2
12	0.48000000E+00	0	0.595E-09	2
13	0.52000000E+00	0	0.414E-08	2
14	0.56000000E+00	0	0.408E-07	2
15	0.56800000E+00	1	0.460E-06	1
16	0.56960000E+00	2	0.672E-09	1
17	0.56992000E+00	3	0.965E-06	0
18	0.57024000E+00	3	0.974E-06	0

Phase (1) terminated
+++++++

PHASE NUMBER = 2
NODAL DISPLACEMENT CONTROL
GLOBAL DIRECTION = Y
CONTROLLED NODE = 4

OUTPUT ITERATIONS	DISPLACEMENT INCREMENT	VARIABLE LOAD FACTOR	LEVEL	CONV.-NORM	
19	-.58886522E-02	0.57032137E+00	0	0.993E-06	1
Plastic hinge formed for element 2 at node 4					
20	-.35331913E-01	0.56783100E+00	0	0.303E-07	2
Plastic hinge formed for element 1 at node 4					
21	-.14132765E+00	0.56085432E+00	0	0.228E-06	2

```

***** ( SUBDIVISION OF ELEMENT 1 ) *****
*
*NUMBER OF NODES CREATED
*      1
* NOD.NAME      COORD'S (X,Y) RELATIVE TO END(1) OF SUBDIVIDED ELEMENT
* #n1           0.537226E+03      0.175588E+04
*-----*
*
*NUMBER OF ELEMENTS CREATED
*      2
* ELM.NAME      TYPE.OF.ELEMENT      NOD.NAMES
* #e1           qph2                 1      #n1
* #e2           qph2                 #n1    4
*-----*
*
*NUMBER OF IMPERFECT ELEMENTS
*      2
* ELM.NAME      TH1I      TH2I      TI
* #e1           -.152581E-02  0.152581E-02  -.700432E+00
* #e2           -.246847E-02  0.246847E-02  -.183324E+01
*****

```

```

***** ( SUBDIVISION OF ELEMENT 2 ) *****
*
*NUMBER OF NODES CREATED
*      1
* NOD.NAME      COORD'S (X,Y) RELATIVE TO END(1) OF SUBDIVIDED ELEMENT
* #n2           0.867206E+03      -.284399E+04
*-----*
*
*NUMBER OF ELEMENTS CREATED
*      2
* ELM.NAME      TYPE.OF.ELEMENT      NOD.NAMES
* #e3           qph2                 4      #n2
* #e4           qph2                 #n2    2
*-----*
*
*NUMBER OF IMPERFECT ELEMENTS
*      2
* ELM.NAME      TH1I      TH2I      TI
* #e3           0.247064E-02  -.247064E-02  0.183647E+01
* #e4           0.152364E-02  -.152364E-02  0.698438E+00
*****

```

```

22      -.56531062E+00      0.53452938E+00      0      0.354E-06      6
Plastic hinge formed for element #e3      at node 4
Plastic hinge formed for element #e2      at node #n1
Plastic hinge formed for element #e2      at node 4
Plastic hinge formed for element #e4      at node #n2
23      -.56531062E+00      0.52314632E+00      0      0.100E-06      5
Plastic hinge formed for element 3      at node 4
24      -.11306212E+01      0.49180805E+00      0      0.988E-06      5
Plastic hinge formed for element 3      at node 3
25      -.22612425E+01      0.45116331E+00      0      0.447E-06      8
Plastic hinge formed for element 4      at node 5
26      -.22612425E+01      0.42323379E+00      0      0.498E-06      6
27      -.22612425E+01      0.40365272E+00      0      0.896E-06      5
28      -.45224849E+01      0.37733661E+00      0      0.803E-06      8
29      -.45224849E+01      0.36011033E+00      0      0.356E-06      7
30      -.45224849E+01      0.34784546E+00      0      0.601E-06      6

```

31	-.45224849E+01	0.33867433E+00	0	0.133E-06	6
32	-.45224849E+01	0.33159941E+00	0	0.623E-06	5
33	-.90449698E+01	0.32159929E+00	0	0.775E-06	8
34	-.90449698E+01	0.31528570E+00	0	0.190E-06	8
35	-.90449698E+01	0.31143394E+00	0	0.798E-06	7
36	-.90449698E+01	0.30938842E+00	0	0.790E-06	7
37	-.90449698E+01	0.30875711E+00	0	0.784E-06	7
38	-.90449698E+01	0.30929004E+00	0	0.401E-06	8
39	-.90449698E+01	0.31082759E+00	0	0.924E-06	7
40	-.90449698E+01	0.31326084E+00	0	0.878E-06	7
Plastic hinge closed for element #e2 at node 4					
41	-.90449698E+01	0.31650563E+00	0	0.473E-06	8
42	-.90449698E+01	0.32032074E+00	0	0.269E-06	9
43	-.90449698E+01	0.32469935E+00	0	0.664E-06	8
44	-.18089940E+01	0.32565287E+00	1	0.121E-07	2
45	-.18089940E+01	0.32663005E+00	1	0.141E-07	2
46	-.18089940E+01	0.32763135E+00	1	0.119E-06	2
Plastic hinge closed for element #e3 at node 4					
47	-.18089940E+01	0.32865710E+00	1	0.137E-07	2
48	-.18089940E+01	0.32970771E+00	1	0.124E-07	2
49	-.90449698E+01	0.33532282E+00	0	0.540E-06	7
50	-.90449698E+01	0.34162424E+00	0	0.229E-06	7
51	-.90449698E+01	0.34866739E+00	0	0.546E-06	6
52	-.90449698E+01	0.35653812E+00	0	0.234E-06	6
53	-.90449698E+01	0.36537081E+00	0	0.672E-06	5
54	-.18089940E+02	0.38688104E+00	0	0.234E-06	6
55	-.18089940E+02	0.41356265E+00	0	0.852E-06	8
56	-.18089940E+02	0.44388832E+00	0	0.542E-06	8
57	-.18089940E+02	0.47725230E+00	0	0.304E-06	6
Plastic hinge formed for element 4 at node 4					
58	-.18089940E+02	0.50809231E+00	0	0.571E-06	9
59	-.36179879E+01	0.51444736E+00	1	0.329E-07	2
60	-.36179879E+01	0.52086955E+00	1	0.348E-07	2
61	-.36179879E+01	0.52735930E+00	1	0.362E-07	2
62	-.72359759E+00	0.52866515E+00	2	0.412E-06	1
63	-.72359759E+00	0.52995151E+00	2	0.924E-08	2
64	-.72359759E+00	0.53110568E+00	2	0.181E-07	1
65	-.72359759E+00	0.53225959E+00	2	0.181E-07	1
66	-.72359759E+00	0.53341324E+00	2	0.180E-07	1
67	-.36179879E+01	0.53917749E+00	1	0.391E-09	2
68	-.36179879E+01	0.54493498E+00	1	0.384E-09	

9.3 Lee's frame

The Lee's frame, shown in the figure 9.3, is subjected to an end force P. The buckling forces for this frame were also obtained with ADAPTIC, where the following values were reported using 3 elements.

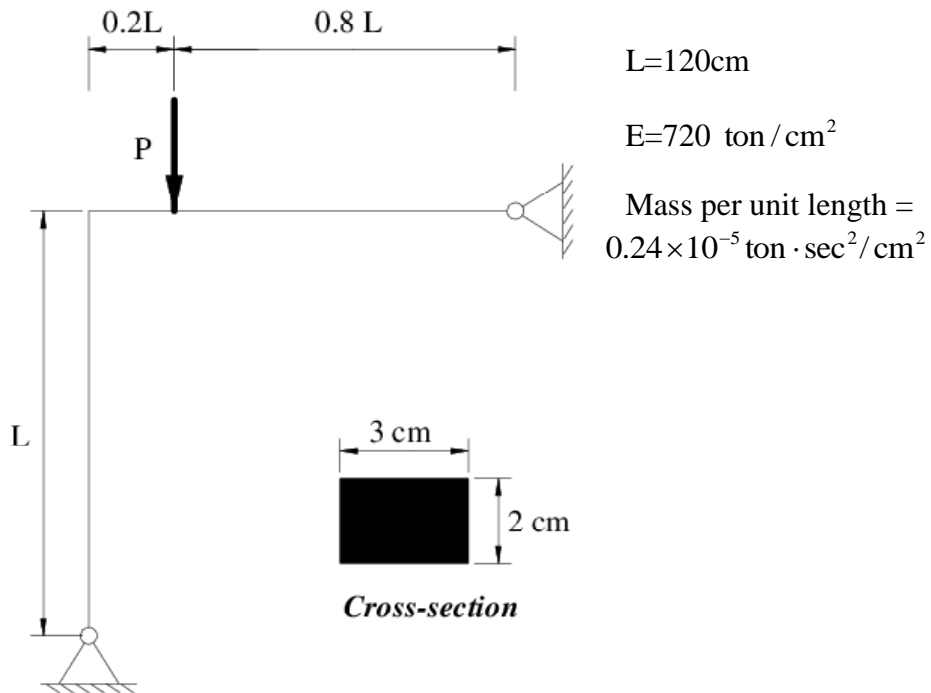

figure 9.3 Geometry and loading of Lee's frame.

9.3.1 Data file

```
#
analysis 2d statics (a)
# control start
#
#
materials (b)
  mat.name      model properties
  mat1          stl1 0.720e3 0.100e1 0.00
#
sections (c)
  type = rss
  sec.name      mat.name      dimensions
  sect1         mat1          3.0 2.0
#
groups (d)
type.of.element = gel2
  grp.name      sec.name
  grp1          sect1
#
structural (e)
  nod.n        x      y
  1            0.00   0.00
  2            0.00   120.00
  3            24.00  120.00
  4            120.00 120.00
#
restraints (g)
  nod.name     direction
  1            x+y
  4            x+y
#
element.connectivity (h)
  elm.name     grp.name      nod.
  f 1          grp1          1 2
  r 1          -              1 1 2
#
applied.loading (i)
proportional.loads
  nod.name     direction      type      value
  3            y              force     -0.10e+1
#
condition (o)
  lf.cnd.name  limits
  1            -2.0 2.0
  disp.cnd.name nod.name      direction      limits
  2            3              x              -0.12e+3 0.12e+3
  3            3              y              -0.12e+3 0.12e+3
#
phases (j)
load.control
  increment    path      steps
  0.2e+1       k         20
automatic.control
  type         path      cnd.name
  nodal translation c         1 2 3
#
iterative.strategy (k)
number = 5
```

```
initial.reformations = 5
step.reduction = 5
divergence.iteration = 4
maximum.convergence = 0.1e3
#
convergence.criteria (1)
  tolerance = 0.1e-5
  force = 0.2e+1
  mome = 0.1e+3
#
output (m)
frequency 0
#
end
```

Note: The elements and the nodes that are used are shown in the figure 9.3.1.

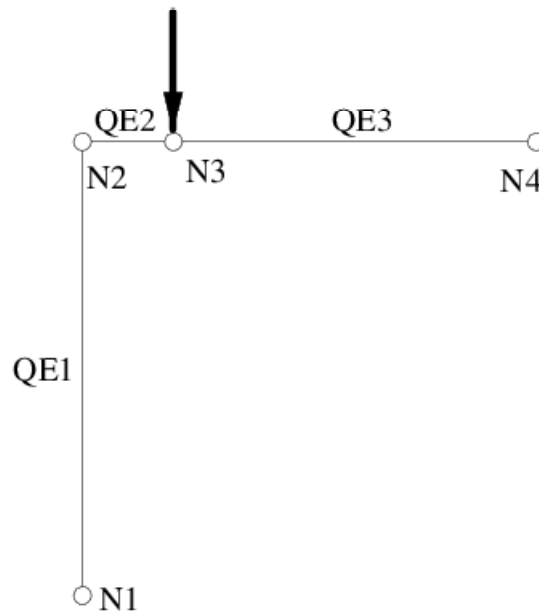

figure 9.3.1 Nodes and elements of Lee's frame.

9.3.2 Structural behaviour

The nonlinear analysis is undertaken using one element per member. The following figures show the static response of Lee's frame.

The node 1 only experiments rotation, as could be seen in the figure. It has the same behaviour as the node 4.

The nodes 2 and 3 have similar behaviour,

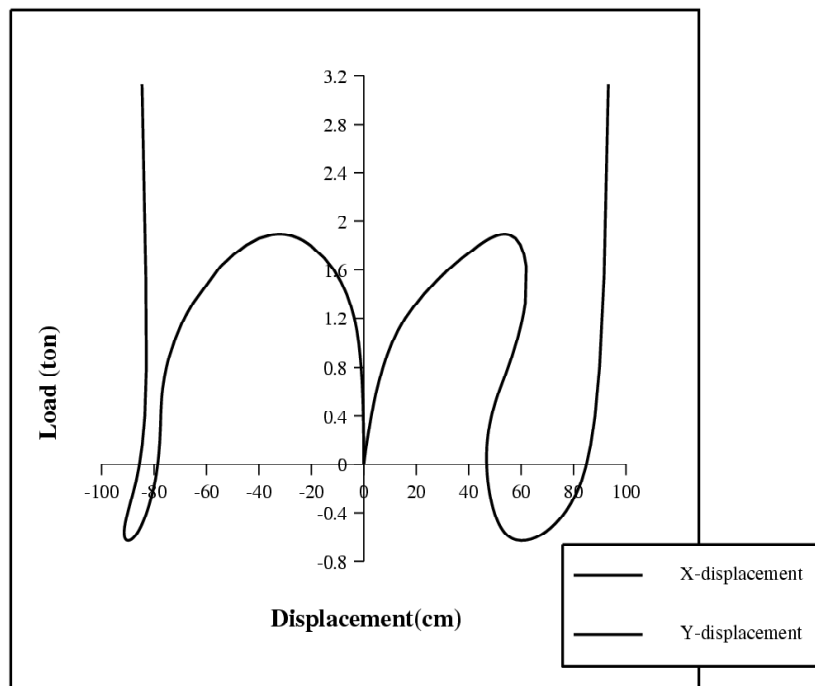

figure 9.3.2a Static response of Lee's frame at node 3.

This is the deformed shape of the Lee's frame. As it could be seen, nodes 1 and 4 only experiment rotation, and the displacements of node 2 are bigger than the displacements of node 3, even the develop in the time follows the same tendency.

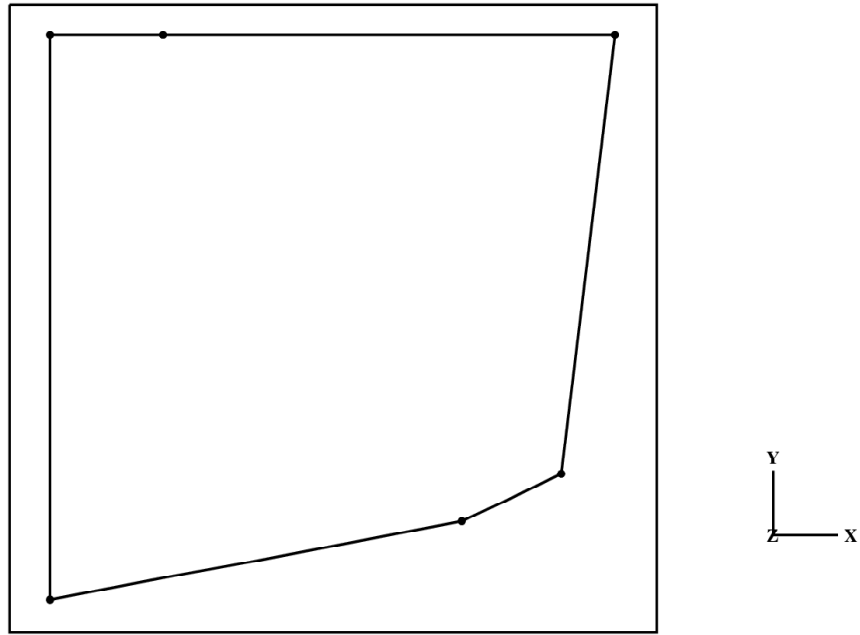

figure 9.3.2b Deflected shape of Lee's frame.

The real deflected shape of Lee's frame when the load increase vary like is shown in the following figure.

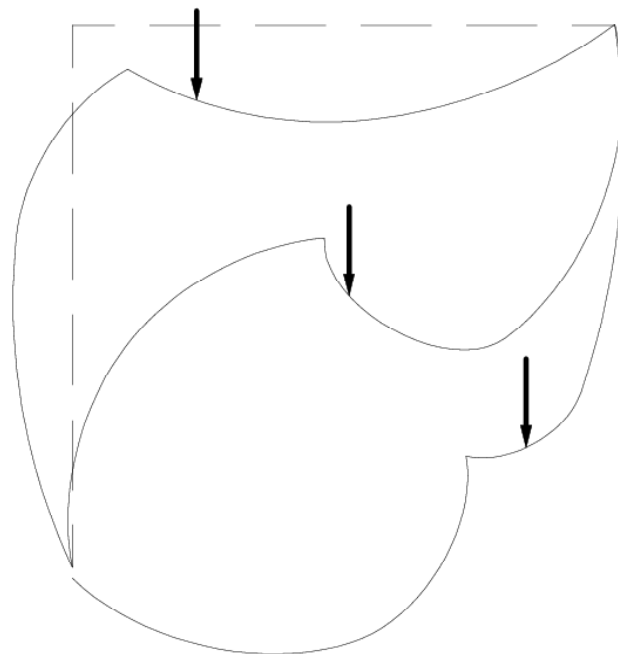

figure 9.3.2c Deflected shape of Lee's frame during static loading.

9.3.3 Output file

```

ELEMENT ASSEMBLY ORDER
----->>>> ----->>>> ----->>>> ----->>>> ----->>>> ----->>>> ----->>>>
1           2           3

```

```

MAXIMUM FRONT: (NODAL = 2) - (ADDITIONAL FREEDOMS = 0)
+++++

```

```

VARIABLE LOADING
+++++

```

```

PHASE NUMBER = 1
TYPE = LOAD CONTROL
INCREMENT FACTOR =0.200000E+01
NUMBER OF STEPS = 20

```

OUTPUT	VARIABLE LOAD FACTOR	LEVEL	CONV.-NORM	ITERATIONS
1	0.10000000E+00	0	0.489E-09	3
2	0.20000000E+00	0	0.926E-08	3
3	0.30000000E+00	0	0.304E-07	3
4	0.40000000E+00	0	0.392E-07	3
5	0.50000000E+00	0	0.357E-07	3
6	0.60000000E+00	0	0.314E-07	3
7	0.70000000E+00	0	0.305E-07	3
8	0.80000000E+00	0	0.343E-07	3
9	0.90000000E+00	0	0.459E-07	3
10	0.10000000E+01	0	0.711E-07	3
11	0.11000000E+01	0	0.118E-06	3
12	0.12000000E+01	0	0.187E-06	3
13	0.13000000E+01	0	0.242E-06	3
14	0.14000000E+01	0	0.244E-06	3
15	0.15000000E+01	0	0.245E-06	3
16	0.16000000E+01	0	0.434E-06	3
17	0.17000000E+01	0	0.152E-11	4
18	0.18000000E+01	0	0.100E-08	4
19	0.18200000E+01	1	0.380E-12	3
20	0.18400000E+01	1	0.529E-11	3
21	0.18600000E+01	1	0.197E-09	3
22	0.18800000E+01	1	0.803E-07	3
23	0.18840000E+01	2	0.736E-07	2
24	0.18880000E+01	2	0.499E-06	2
25	0.18920000E+01	2	0.340E-09	3
26	0.18928000E+01	3	0.144E-08	2
27	0.18936000E+01	3	0.929E-08	2
28	0.18944000E+01	3	0.145E-06	2
29	0.18952000E+01	3	0.462E-07	3

```

Phase (1) terminated
+++++

```

```

PHASE NUMBER = 2
NODAL DISPLACEMENT CONTROL
GLOBAL DIRECTION = X
CONTROLLED NODE = 2

```

```

VARIABLE
DISPLACEMENT LOAD

```

OUTPUT ITERATIONS	INCREMENT	FACTOR	LEVEL	CONV. -NORM	
30	0.12676487E+01	0.18951791E+01	0	0.635E-09	2
31	0.25352974E+01	0.18902504E+01	0	0.121E-06	2
32	0.50705949E+01	0.18612923E+01	0	0.114E-10	3
33	0.50705949E+01	0.18077847E+01	0	0.405E-11	3
34	0.50705949E+01	0.17303899E+01	0	0.130E-11	3
35	0.50705949E+01	0.16283372E+01	0	0.269E-06	2
36	0.10141190E+02	0.13300448E+01	0	0.612E-07	3
37	0.20282379E+01	0.12478470E+01	1	0.614E-07	2
38	0.20282379E+01	0.11529115E+01	1	0.443E-06	2
39	0.20282379E+01	0.10386773E+01	1	0.630E-11	3
40	0.20282379E+01	0.88635252E+00	1	0.357E-07	3
41	0.40564759E+00	0.84608354E+00	2	0.138E-06	2
42	0.40564759E+00	0.79871870E+00	2	0.702E-12	3
43	0.40564759E+00	0.73803157E+00	2	0.924E-09	3
44	0.40564759E+00	0.63150114E+00	2	0.342E-11	5

Current control type terminated

PHASE NUMBER = 2
NODAL DISPLACEMENT CONTROL
GLOBAL DIRECTION = Y
CONTROLLED NODE = 3

OUTPUT ITERATIONS	DISPLACEMENT INCREMENT	VARIABLE LOAD FACTOR	LEVEL	CONV. -NORM	
45	0.67338419E+00	0.59122201E+00	0	0.842E-12	3
46	0.67338419E+00	0.54930670E+00	0	0.341E-10	3
47	0.67338419E+00	0.50485740E+00	0	0.297E-08	3
48	0.67338419E+00	0.45652421E+00	0	0.761E-11	4
49	0.13467684E+00	0.44621774E+00	1	0.752E-08	2
50	0.13467684E+00	0.43564685E+00	1	0.145E-07	2
51	0.13467684E+00	0.42478342E+00	1	0.295E-07	2
52	0.13467684E+00	0.41359499E+00	1	0.628E-07	2
53	0.13467684E+00	0.40204378E+00	1	0.141E-06	2
54	0.67338419E+00	0.33693690E+00	0	0.905E-10	4
55	0.13467684E+00	0.32186952E+00	1	0.877E-12	3
56	0.13467684E+00	0.30581535E+00	1	0.382E-08	3
57	0.13467684E+00	0.28855344E+00	1	0.605E-07	3
58	0.13467684E+00	0.26977110E+00	1	0.122E-06	3
59	0.13467684E+00	0.24899930E+00	1	0.141E-06	3
60	0.13467684E+00	0.22547457E+00	1	0.236E-06	3
61	0.13467684E+00	0.19778790E+00	1	0.448E-11	4
62	0.13467684E+00	0.16268829E+00	1	0.454E-07	4
63	0.26935367E-01	0.15410827E+00	2	0.504E-07	2
64	0.26935367E-01	0.14468054E+00	2	0.123E-06	2
65	0.26935367E-01	0.13410380E+00	2	0.381E-06	2
66	0.26935367E-01	0.12184021E+00	2	0.594E-11	3
67	0.26935367E-01	0.10672673E+00	2	0.851E-09	3
68	0.26935367E-01	0.84875270E-01	2	0.245E-09	4
69	0.53870735E-02	0.78273464E-01	3	0.225E-06	2
70	0.53870735E-02	0.69112846E-01	3	0.146E-08	3

Current control type terminated

PHASE NUMBER = 2
 NODAL DISPLACEMENT CONTROL
 GLOBAL DIRECTION = Y
 CONTROLLED NODE = 2

OUTPUT ITERATIONS	DISPLACEMENT INCREMENT	VARIABLE LOAD FACTOR	LEVEL	CONV. -NORM	
71	-.80789915E-01	0.57646662E-01	0	0.884E-08	2
72	-.16157983E+00	0.36441746E-01	0	0.848E-06	2
73	-.32315966E+00	-.97531927E-03	0	0.948E-10	3
74	-.32315966E+00	-.33812188E-01	0	0.341E-11	3
75	-.32315966E+00	-.63438327E-01	0	0.972E-12	3
76	-.32315966E+00	-.90632858E-01	0	0.581E-12	3
77	-.32315966E+00	-.11588821E+00	0	0.602E-06	2
78	-.64631932E+00	-.16182271E+00	0	0.508E-10	3
79	-.64631932E+00	-.20296138E+00	0	0.685E-11	3
80	-.64631932E+00	-.24029833E+00	0	0.100E-11	3
81	-.64631932E+00	-.27447033E+00	0	0.390E-12	3
82	-.64631932E+00	-.30591620E+00	0	0.523E-12	3
83	-.64631932E+00	-.33495588E+00	0	0.367E-12	3
84	-.64631932E+00	-.36183352E+00	0	0.935E-06	2
85	-.12926386E+01	-.40984154E+00	0	0.134E-09	3
86	-.12926386E+01	-.45112304E+00	0	0.383E-10	3
87	-.12926386E+01	-.48654527E+00	0	0.124E-10	3
88	-.12926386E+01	-.51679131E+00	0	0.451E-11	3
89	-.12926386E+01	-.54242477E+00	0	0.223E-11	3
90	-.12926386E+01	-.56392427E+00	0	0.639E-12	3
91	-.12926386E+01	-.58170326E+00	0	0.672E-12	3
92	-.12926386E+01	-.59612224E+00	0	0.356E-12	3
93	-.12926386E+01	-.60749699E+00	0	0.447E-12	3
94	-.12926386E+01	-.61610455E+00	0	0.157E-12	3
95	-.12926386E+01	-.62218784E+00	0	0.862E-06	2
96	-.25852773E+01	-.62760442E+00	0	0.252E-09	3
97	-.25852773E+01	-.62513542E+00	0	0.778E-10	3
98	-.25852773E+01	-.61580883E+00	0	0.253E-10	3
99	-.25852773E+01	-.60034713E+00	0	0.873E-11	3
100	-.25852773E+01	-.57920181E+00	0	0.269E-11	3
101	-.25852773E+01	-.55256728E+00	0	0.146E-11	3
102	-.25852773E+01	-.52037179E+00	0	0.457E-12	3
103	-.25852773E+01	-.48223868E+00	0	0.428E-12	3
104	-.25852773E+01	-.43740453E+00	0	0.246E-12	3
105	-.25852773E+01	-.38456730E+00	0	0.637E-12	3
106	-.25852773E+01	-.32161248E+00	0	0.132E-11	3
107	-.25852773E+01	-.24511144E+00	0	0.206E-11	3
108	-.25852773E+01	-.14937073E+00	0	0.499E-11	3
109	-.25852773E+01	-.24547529E-01	0	0.116E-10	3
110	-.25852773E+01	0.14728750E+00	0	0.242E-10	3
111	-.25852773E+01	0.40093190E+00	0	0.581E-10	3
112	-.25852773E+01	0.80974686E+00	0	0.339E-09	3
113	-.25852773E+01	0.15494444E+01	0	0.417E-08	3
114	-.25852773E+01	0.31338199E+01	0	0.310E-06	3

9.4 Fixed ended beam-column

The fixed ended beam-column, shown in the figure 9.4, is subjected to two vertical symmetric forces P , and to an horizontal force. The buckling forces for this frame where obtained using 3 elements.

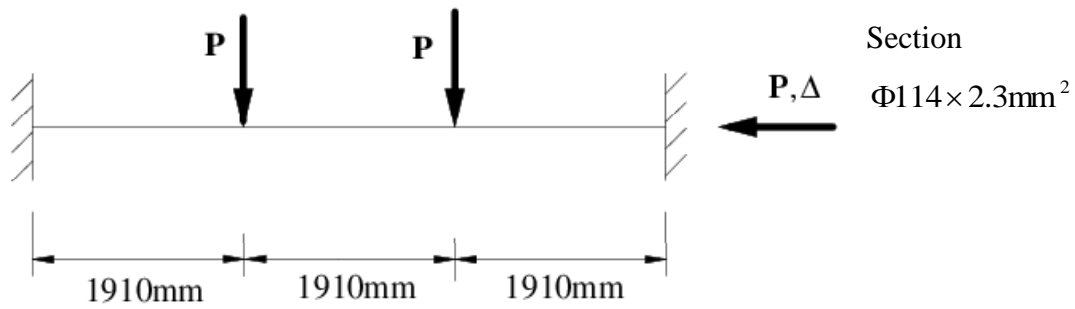

figure 9.4 Geometry of fixed ended beam-column.

9.4.1 Data file

```
#
analysis 2d statics \(a\)

#
materials \(b\)

mat.name      model      properties
mat1          st12 & # 42 properties for multisurface steel model follow
0.210000e+06  0.100000e-02  0.200000e-02 &
0.600000e-02  0.210000e-01  0.306000e-01 &
0.187850e+03  0.101150e+06  0.260100e+03 &
0.433500e+05  0.289000e+03  0.867000e+04 &
0.306340e+03  0.115600e+04  0.323680e+03 &
0.120417e+04  0.335240e+03  0.104278e+04 &
0.187850e+03  0.101150e+06  0.260100e+03 &
0.433500e+05  0.289000e+03  0.867000e+04 &
0.306340e+03  0.115600e+04  0.323680e+03 &
0.120417e+04  0.335240e+03  0.104278e+04 &
0.000000e+00  0.000000e+00  0.000000e+00 &
0.000000e+00  0.000000e+00  0.000000e+00 &
0.000000e+00  0.000000e+00  0.000000e+00 &
0.000000e+00  0.000000e+00  0.000000e+00 &
0.000000e+00  0.000000e+00  0.000000e+00 &

sections \(c\)
  type = chs
# circular hollow section
  sec.name      mat.name      dimensions
  sect1        mat1          114.0  2.3

#
patterns \(p\)
# subdivision patterns for elements "qdp2"
pat.name      ratios
pat1          1 2 3 4 5      # 5 subelements; smallest near 1st node
pat2          3 2 1 2 3      # 5 subelements; smallest in the middle

#
groups \(d\)

type = cbp2
grp.name      sec.name      monitoring.points
grp1          sect1          40

#
type = qdp2
grp.name      cbp2.grp.name  pat.name
grp2          grp1          pat1
grp3          grp1          pat2

#
structural.nodal \(e\)
  nod.name      x          y
  1             0.0        0.0
  2             1910.0     0.0
  3             3810.0     0.0
  4             5720.0     0.0

#
restraints \(g\)
nod.name      direction
1             x+y+rz
4             y+rz

#
```

```

element.connectivity (h)

  elm.name   grp.name nod.name
    1         grp2    1  2
    2         grp3    2  3
    3         grp2    4  3
#
linear.curves # curves for time history loads
start.time = 0.0
crv.name = c1
  time   load.factor
    1     -1.0
    3      1.0
    5     -1.0
#
applied.loading (i)
  initial
    nod.name   direction   type   value
    f 2        y           force  -0.1005e+4
    r 1        -           -      0.0      1
  time.history
    nod.name   direction   type   crv.name  value
    4          x           disp   c1        40.0
#
equilibrium.stages
  end.of.stage  steps
    5.0         200
# use default iterative strategy
convergence.criteria (l)
  tolerance = 0.1e-5
  force.ref = 0.1e+6
  moment.ref = 0.1e+8
#
output (m)
frequency 0 stress # all equilibrium steps including step reduction
levels
#
end

```

Note The following picture shows the names that have been given to the nodes and elements in the data file.

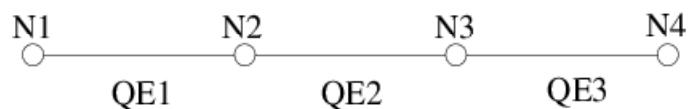

figure 9.4.1 Nodes and elements of fixed ended beam-column.

9.4.2 Structural behaviour

The nonlinear analysis is undertaken using one element per member. The following figures show the static response of fixed ended beam-column.

The nodes 1 and 4, only experiments rotation. The nodes 2 experiments a small displacement in X-axes and a bigger one in the Y-axes, and does not exist any rotation.

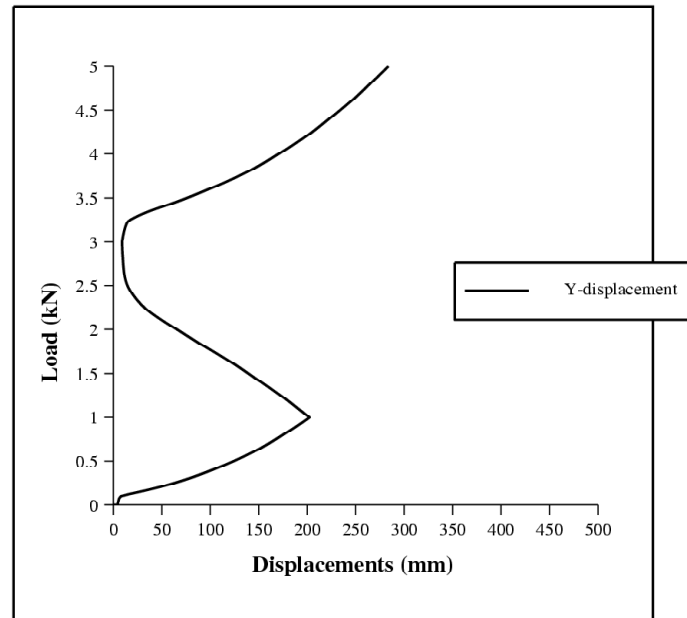

figure 9.4.2b Displacements of fixed ended beam-column.

The deformed shape that experiments the beam subject at those loads is the following one:

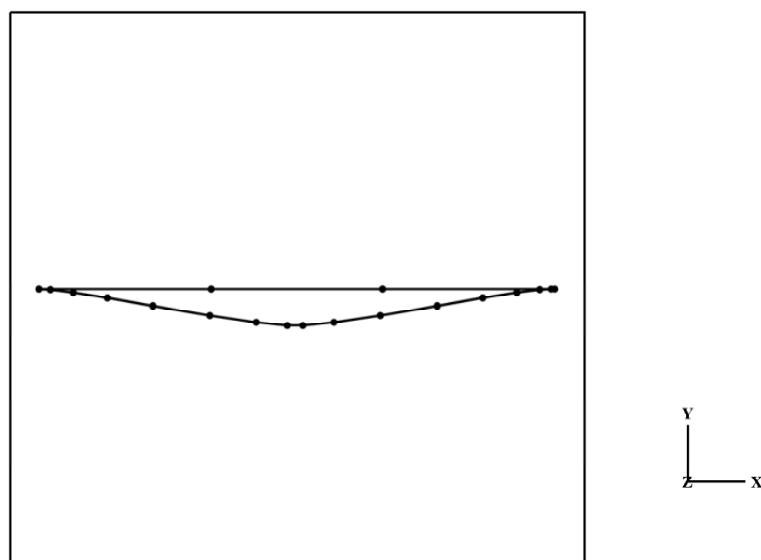

figure 9.4.2b Deflected Shape of fixed ended beam-column.

9.4.3 Output file

ELEMENT ASSEMBLY ORDER

```
----->>>  ----->>>  ----->>>  ----->>>  ----->>>  ----->>>  ----->>>
1           2           3
```

MAXIMUM FRONT: (NODAL = 3) - (ADDITIONAL FREEDOMS = 0)
 ++++++

INITIAL LOADING
 ++++++

OUTPUT ITERATIONS	INITIAL LOADING FACTOR	CURRENT TIME	LEVEL	CONV.-NORM	
1	0.10000000E+01	0.00000000E+00	0	0.303E-07	1

VARIABLE LOADING
 ++++++

OUTPUT	CURRENT TIME	LEVEL	CONV.-NORM	ITERATIONS
2	0.25000000E-01	0	0.326E-06	1
3	0.50000000E-01	0	0.584E-06	1
4	0.75000000E-01	0	0.155E-12	2

```
***** ( SUBDIVISION OF ELEMENT 1 ) *****
*
*NUMBER OF NODES CREATED
*           3
* NOD.NAME      COORD'S (X,Y) RELATIVE TO END(1) OF SUBDIVIDED ELEMENT
* #n1           0.127333E+03      0.000000E+00
* #n2           0.382000E+03      0.000000E+00
* #n3           0.764000E+03      0.000000E+00
*-----*
*
*NUMBER OF ELEMENTS CREATED
*           4
* ELM.NAME      TYPE.OF.ELEMENT      NOD.NAMES
* #e1           cbp2                  1      #n1
* #e2           cbp2                  #n1    #n2
* #e3           cbp2                  #n2    #n3
* #e4           qdp2                  #n3    2
*-----*
*
*NUMBER OF IMPERFECT ELEMENTS
*           0
*****
```

```
***** ( SUBDIVISION OF ELEMENT 2 ) *****
*
*NUMBER OF NODES CREATED
*           4
* NOD.NAME      COORD'S (X,Y) RELATIVE TO END(1) OF SUBDIVIDED ELEMENT
* #n4           0.518182E+03      0.000000E+00
* #n5           0.863636E+03      0.000000E+00
* #n6           0.103636E+04      0.000000E+00
```

```

* #n7          0.138182E+04          0.000000E+00          *
*-----*
*
*NUMBER OF ELEMENTS CREATED          *
*          5          *
* ELM.NAME      TYPE.OF.ELEMENT      NOD.NAMES          *
* #e5           cbp2                 2          #n4          *
* #e6           cbp2                 #n4         #n5          *
* #e7           cbp2                 #n5         #n6          *
* #e8           cbp2                 #n6         #n7          *
* #e9           cbp2                 #n7         3          *
*-----*
*
*NUMBER OF IMPERFECT ELEMENTS          *
*          0          *
*****

***** ( SUBDIVISION OF ELEMENT 3 ) *****
*
*NUMBER OF NODES CREATED          *
*          3          *
* NOD.NAME      COORD'S (X,Y) RELATIVE TO END(1) OF SUBDIVIDED ELEMENT *
* #n8           -.127333E+03         0.000000E+00      *
* #n9           -.382000E+03         0.000000E+00      *
* #n10          -.764000E+03         0.000000E+00      *
*-----*
*
*NUMBER OF ELEMENTS CREATED          *
*          4          *
* ELM.NAME      TYPE.OF.ELEMENT      NOD.NAMES          *
* #e10          cbp2                 4          #n8          *
* #e11          cbp2                 #n8         #n9          *
* #e12          cbp2                 #n9         #n10         *
* #e13          qdp2                 #n10        3          *
*-----*
*
*NUMBER OF IMPERFECT ELEMENTS          *
*          0          *
*****

          5          0.10000000E+00      0          0.888E-07          3

***** ( SUBDIVISION OF ELEMENT #e4 ) *****
*
*NUMBER OF NODES CREATED          *
*          1          *
* NOD.NAME      COORD'S (X,Y) RELATIVE TO END(1) OF SUBDIVIDED ELEMENT *
* #n11          0.509333E+03         0.000000E+00      *
*-----*
*
*NUMBER OF ELEMENTS CREATED          *
*          2          *
* ELM.NAME      TYPE.OF.ELEMENT      NOD.NAMES          *
* #e14          cbp2                 #n3         #n11         *
* #e15          cbp2                 #n11        2          *
*-----*
*
*NUMBER OF IMPERFECT ELEMENTS          *
*          0          *
*****

```

```

***** ( SUBDIVISION OF ELEMENT #e13 )*****
*
*NUMBER OF NODES CREATED
* 1
* NOD.NAME COORD'S (X,Y) RELATIVE TO END(1) OF SUBDIVIDED ELEMENT
* #n12 -.509333E+03 0.000000E+00
*-----*
*
*NUMBER OF ELEMENTS CREATED
* 2
* ELM.NAME TYPE.OF.ELEMENT NOD.NAMES
* #e16 cbp2 #n10 #n12
* #e17 cbp2 #n12 3
*-----*
*
*NUMBER OF IMPERFECT ELEMENTS
* 0
*****

```

6	0.12500000E+00	0	0.665E-07	3
7	0.15000000E+00	0	0.219E-06	2
8	0.17500000E+00	0	0.437E-06	2
9	0.20000000E+00	0	0.195E-06	2
10	0.22500000E+00	0	0.177E-06	2
11	0.25000000E+00	0	0.161E-06	2
12	0.27500000E+00	0	0.116E-06	2
13	0.30000000E+00	0	0.349E-07	2
14	0.32500000E+00	0	0.208E-08	3
15	0.35000000E+00	0	0.206E-09	3
16	0.37500000E+00	0	0.233E-08	3
17	0.40000000E+00	0	0.508E-07	2
18	0.42500000E+00	0	0.411E-07	2
19	0.45000000E+00	0	0.731E-07	2
20	0.47500000E+00	0	0.574E-07	2
21	0.50000000E+00	0	0.254E-07	2
22	0.52500000E+00	0	0.410E-07	2
23	0.55000000E+00	0	0.841E-07	2
24	0.57500000E+00	0	0.355E-09	3
25	0.60000000E+00	0	0.478E-07	2
26	0.62500000E+00	0	0.103E-06	2
27	0.65000000E+00	0	0.138E-08	3
28	0.67500000E+00	0	0.157E-09	3
29	0.70000000E+00	0	0.481E-07	2
30	0.72500000E+00	0	0.342E-07	2
31	0.75000000E+00	0	0.191E-07	2
32	0.77500000E+00	0	0.186E-07	2
33	0.80000000E+00	0	0.183E-07	2
34	0.82500000E+00	0	0.575E-09	3
35	0.85000000E+00	0	0.173E-07	2
36	0.87500000E+00	0	0.128E-07	2
37	0.90000000E+00	0	0.133E-07	2
38	0.92500000E+00	0	0.242E-07	2
39	0.95000000E+00	0	0.425E-09	3
40	0.97500000E+00	0	0.186E-09	3
41	0.10000000E+01	0	0.263E-09	3
42	0.10250000E+01	0	0.312E-08	2
43	0.10500000E+01	0	0.829E-07	1
44	0.10750000E+01	0	0.828E-07	1
45	0.11000000E+01	0	0.822E-07	1

46	0.11250000E+01	0	0.811E-07	1
47	0.11500000E+01	0	0.795E-07	1
48	0.11750000E+01	0	0.772E-07	1
49	0.12000000E+01	0	0.743E-07	1
50	0.12250000E+01	0	0.706E-07	1
51	0.12500000E+01	0	0.692E-07	1
52	0.12750000E+01	0	0.277E-06	2
53	0.13000000E+01	0	0.250E-08	2
54	0.13250000E+01	0	0.394E-07	2
55	0.13500000E+01	0	0.102E-08	2
56	0.13750000E+01	0	0.829E-08	2
57	0.14000000E+01	0	0.215E-07	2
58	0.14250000E+01	0	0.139E-07	2
59	0.14500000E+01	0	0.226E-07	2
60	0.14750000E+01	0	0.398E-07	2
61	0.15000000E+01	0	0.120E-06	2
62	0.15250000E+01	0	0.179E-06	2
63	0.15500000E+01	0	0.105E-06	2
64	0.15750000E+01	0	0.634E-07	2
65	0.16000000E+01	0	0.234E-07	2
66	0.16250000E+01	0	0.314E-07	2
67	0.16500000E+01	0	0.202E-07	2
68	0.16750000E+01	0	0.932E-07	2
69	0.17000000E+01	0	0.182E-07	2
70	0.17250000E+01	0	0.343E-07	2
71	0.17500000E+01	0	0.450E-07	2
72	0.17750000E+01	0	0.322E-06	2
73	0.18000000E+01	0	0.359E-06	2
74	0.18250000E+01	0	0.231E-07	2
75	0.18500000E+01	0	0.204E-06	2
76	0.18750000E+01	0	0.411E-06	2
77	0.19000000E+01	0	0.124E-08	3
78	0.19250000E+01	0	0.160E-07	2
79	0.19500000E+01	0	0.516E-06	2
80	0.19750000E+01	0	0.515E-06	2
81	0.20000000E+01	0	0.174E-07	2
82	0.20250000E+01	0	0.357E-07	2
83	0.20500000E+01	0	0.145E-06	2
84	0.20750000E+01	0	0.232E-07	2
85	0.21000000E+01	0	0.532E-08	2
86	0.21250000E+01	0	0.615E-08	2
87	0.21500000E+01	0	0.134E-07	2
88	0.21750000E+01	0	0.358E-08	2
89	0.22000000E+01	0	0.134E-06	2
90	0.22250000E+01	0	0.179E-07	2
91	0.22500000E+01	0	0.372E-07	2
92	0.22750000E+01	0	0.591E-06	2
93	0.23000000E+01	0	0.411E-08	2
94	0.23250000E+01	0	0.491E-07	2
95	0.23500000E+01	0	0.557E-08	2
96	0.23750000E+01	0	0.616E-08	2
97	0.24000000E+01	0	0.508E-08	2
98	0.24250000E+01	0	0.721E-08	2
99	0.24500000E+01	0	0.134E-07	2
100	0.24750000E+01	0	0.487E-06	2
101	0.25000000E+01	0	0.224E-06	2
102	0.25250000E+01	0	0.788E-07	2
103	0.25500000E+01	0	0.223E-07	2
104	0.25750000E+01	0	0.320E-07	2
105	0.26000000E+01	0	0.467E-07	2
106	0.26250000E+01	0	0.382E-07	2

107	0.26500000E+01	0	0.483E-08	2
108	0.26750000E+01	0	0.480E-08	2
109	0.27000000E+01	0	0.457E-08	2
110	0.27250000E+01	0	0.349E-08	2
111	0.27500000E+01	0	0.184E-08	2
112	0.27750000E+01	0	0.934E-06	1
113	0.28000000E+01	0	0.542E-06	1
114	0.28250000E+01	0	0.380E-06	1
115	0.28500000E+01	0	0.542E-06	1
116	0.28750000E+01	0	0.900E-06	1
117	0.29000000E+01	0	0.261E-08	2
118	0.29250000E+01	0	0.299E-08	2
119	0.29500000E+01	0	0.249E-08	2
120	0.29750000E+01	0	0.872E-06	1
121	0.30000000E+01	0	0.512E-06	1
122	0.30250000E+01	0	0.629E-09	2
123	0.30500000E+01	0	0.215E-06	1
124	0.30750000E+01	0	0.303E-06	1
125	0.31000000E+01	0	0.437E-06	1
126	0.31250000E+01	0	0.642E-06	1
127	0.31500000E+01	0	0.967E-06	1
128	0.31750000E+01	0	0.126E-11	2
129	0.32000000E+01	0	0.114E-11	2
130	0.32250000E+01	0	0.173E-08	3
131	0.32500000E+01	0	0.813E-08	3
132	0.32750000E+01	0	0.129E-06	3
133	0.33000000E+01	0	0.670E-07	2
134	0.33250000E+01	0	0.438E-07	2
135	0.33500000E+01	0	0.108E-06	2
136	0.33750000E+01	0	0.344E-06	2
137	0.34000000E+01	0	0.216E-06	2
138	0.34250000E+01	0	0.289E-06	2
139	0.34500000E+01	0	0.232E-06	2
140	0.34750000E+01	0	0.135E-08	3
141	0.35000000E+01	0	0.126E-07	3
142	0.35250000E+01	0	0.888E-07	2
143	0.35500000E+01	0	0.649E-07	2
144	0.35750000E+01	0	0.300E-06	2
145	0.36000000E+01	0	0.357E-06	2
146	0.36250000E+01	0	0.264E-08	3
147	0.36500000E+01	0	0.194E-08	3
148	0.36750000E+01	0	0.214E-09	3
149	0.37000000E+01	0	0.420E-06	2
150	0.37250000E+01	0	0.760E-07	2
151	0.37500000E+01	0	0.408E-07	2
152	0.37750000E+01	0	0.200E-06	2
153	0.38000000E+01	0	0.268E-08	3
154	0.38250000E+01	0	0.162E-09	3
155	0.38500000E+01	0	0.202E-09	3
156	0.38750000E+01	0	0.139E-09	3
157	0.39000000E+01	0	0.126E-10	3
158	0.39250000E+01	0	0.110E-10	3
159	0.39500000E+01	0	0.614E-09	2
160	0.39750000E+01	0	0.307E-09	2
161	0.40000000E+01	0	0.225E-06	2
162	0.40250000E+01	0	0.973E-08	2
163	0.40500000E+01	0	0.653E-06	2
164	0.40750000E+01	0	0.920E-06	2
165	0.41000000E+01	0	0.256E-09	2
166	0.41250000E+01	0	0.154E-09	2
167	0.41500000E+01	0	0.113E-08	2

168	0.41750000E+01	0	0.343E-08	2
169	0.42000000E+01	0	0.348E-09	2
170	0.42250000E+01	0	0.410E-08	2
171	0.42500000E+01	0	0.139E-08	2
172	0.42750000E+01	0	0.102E-07	2
173	0.43000000E+01	0	0.602E-10	3
174	0.43250000E+01	0	0.174E-08	2
175	0.43500000E+01	0	0.148E-06	2
176	0.43750000E+01	0	0.331E-08	2
177	0.44000000E+01	0	0.256E-08	2
178	0.44250000E+01	0	0.971E-10	3
179	0.44500000E+01	0	0.592E-09	2
180	0.44750000E+01	0	0.194E-09	2
181	0.45000000E+01	0	0.930E-09	2
182	0.45250000E+01	0	0.924E-09	2
183	0.45500000E+01	0	0.946E-09	2
184	0.45750000E+01	0	0.320E-10	3
185	0.46000000E+01	0	0.104E-08	2
186	0.46250000E+01	0	0.999E-09	2
187	0.46500000E+01	0	0.332E-08	2
188	0.46750000E+01	0	0.582E-09	2
189	0.47000000E+01	0	0.398E-10	2
190	0.47250000E+01	0	0.430E-10	2
191	0.47500000E+01	0	0.175E-09	2
192	0.47750000E+01	0	0.142E-09	2
193	0.48000000E+01	0	0.729E-10	2
194	0.48250000E+01	0	0.107E-09	2
195	0.48500000E+01	0	0.164E-09	2
196	0.48750000E+01	0	0.208E-09	2
197	0.49000000E+01	0	0.130E-08	2
198	0.49250000E+01	0	0.676E-10	3
199	0.49500000E+01	0	0.486E-09	2
200	0.49750000E+01	0	0.543E-09	2
201	0.50000000E+01	0	0.137E-09	2

9.5 Two-storey frame

This example illustrates the influence of an earthquake on the resistance of steel frames.

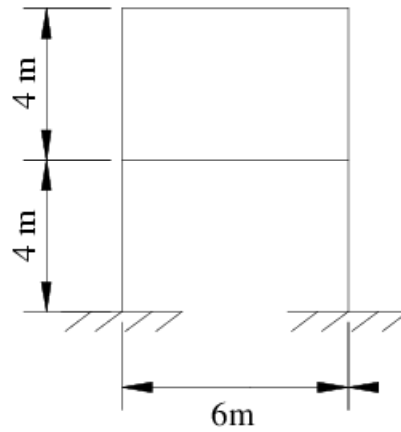

figure 9.5 Steel frames subject to earthquake.

9.5.1 Data file

```
#
analysis 2d dynamics \(a\)
#
materials \(b\)
  mat.name      model      properties
  mat1          st11      0.210e12 0.300e9 0.100e-1
#
sections \(c\)
  type = rss
  sec.name      mat.name      dimensions
  sect1         mat1          0.10 0.10
#
patterns \(p\)
  pat.name      ratios
  pat1          1 2 3 3 2 1
#
groups \(d\)
type = cbp2
  grp.name      sec.name      monitoring.points
  grp1          sect1         30

type = gdp2
  grp.name      cbp2.grp.name  pat.name
  grp2          grp1          pat1

type = cnm2
  grp.name      mass
  grp3          20000
#
structural \(e\)
  nod.n        x      y
  f 1          0.0    0.0
  r 1          6.0    0.0 1
  r 2          0.0    4.0 2
#
restraints \(f\)
  direction = y+rz
  nod.name
  1
  2
#
element.connectivity \(g\)
  grp.name = grp2
  elm.name      nod.name
  f 1           1 3
  r 1           1 1 1
  r 2           2 2 1
  5             3 4
  6             5 6
  grp.name = grp3
  elm.name      nod.name
  f 10          3
  r 1           1 3
#
integration \(r\)
scheme = newmark
beta = 0.25
gamma = 0.5
```

```

#
linear.curves \(q\)
start.time = 0.0
crv.name = crv1
file = earthquake1
first.line = 1
last.line = 1200
format = (23x,2(e15.8,2x))
#
equilibrium.stages \(s\)
    end.of.stage      steps
    5                  500
#
applied.loading \(i\)
dynamic
    nod.name      direction      type      crv.name      value
    f 1           x              acceleration  crv1          9.81
    r 1           -              -          -             0 1
#
iterative.strategy \(k\)
number = 10
initial.reformations = 7
step.reduction = 10
divergence.iteration = 7
maximum.convergence = 1.0
#
convergence.criteria \(l\)
tolerance = 0.1e-3
displacement.ref = 1.0
rotation.ref = 1.0
#
output \(m\)
frequency 2
#
end

```

Note The following picture shows the names that have been given to the nodes and elements in the data file.

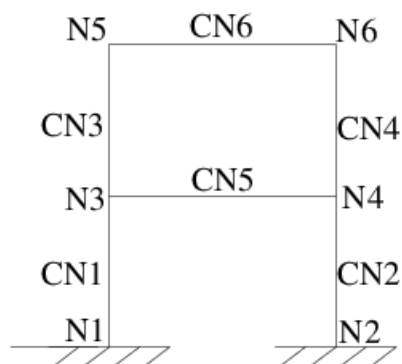

figure 9.5.1 Nodes and elements of the two-storey.

9.5.2 Structural behaviour

The nonlinear analysis is undertaken using one element per member. The following figures show the dynamic response of the structure.

The displacements of the node 121 at the Y-axes are almost inexistent compare into the ones at the X-axes, which vary with the time.

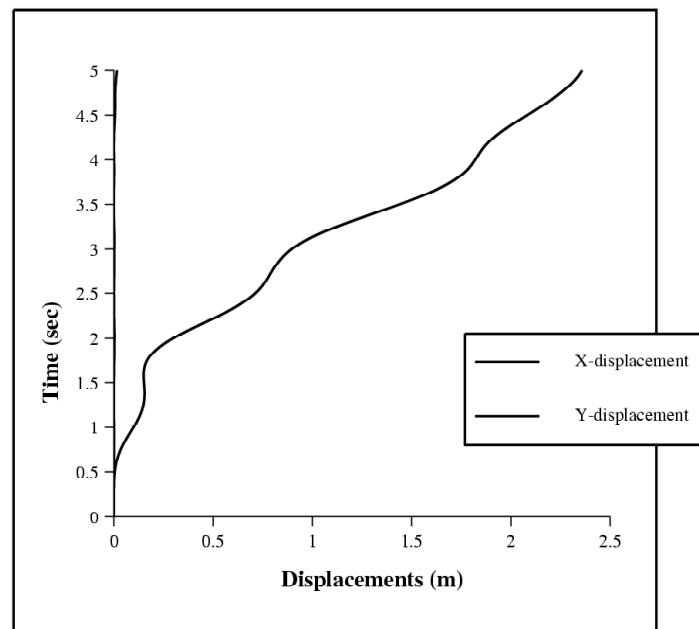

figure 9.5.2b Displacements of two-storey.

The deformed shape given by ADAPTIC is the one shown in the figure, where could be seen that the main effect of the earthquake is a translation of the structure.

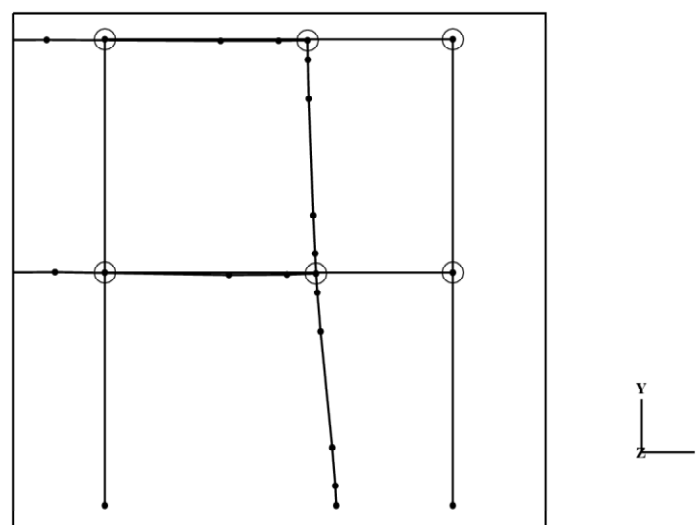

figure 9.5.2b Deflected Shape of two-storey.

9.5.3 Output file

```

ELEMENT ASSEMBLY ORDER
----->>>> ----->>>> ----->>>> ----->>>> ----->>>> ----->>>> ----->>>>
1           3           5           10          6           12           4           13
2           11

```

```

MAXIMUM FRONT: (NODAL = 4) - (ADDITIONAL FREEDOMS = 0)
+++++

```

```

VARIABLE LOADING
+++++

```

OUTPUT	CURRENT TIME	LEVEL	CONV.-NORM	ITERATIONS
0	0.10000000E-01	0	0.147E-06	0
1	0.20000000E-01	0	0.736E-06	0
0	0.30000000E-01	0	0.190E-05	0
2	0.40000000E-01	0	0.362E-05	0
0	0.50000000E-01	0	0.516E-05	0
3	0.60000000E-01	0	0.511E-05	0
0	0.70000000E-01	0	0.128E-05	0
4	0.80000000E-01	0	0.932E-05	0
0	0.90000000E-01	0	0.261E-04	0
5	0.10000000E+00	0	0.449E-04	0
0	0.11000000E+00	0	0.622E-04	0
6	0.12000000E+00	0	0.750E-04	0
0	0.13000000E+00	0	0.795E-04	0
7	0.14000000E+00	0	0.716E-04	0
0	0.15000000E+00	0	0.485E-04	0
8	0.16000000E+00	0	0.884E-05	0
0	0.17000000E+00	0	0.509E-04	0
9	0.18000000E+00	0	0.860E-09	1
0	0.19000000E+00	0	0.266E-08	1
10	0.20000000E+00	0	0.556E-08	1
0	0.21000000E+00	0	0.895E-08	1
11	0.22000000E+00	0	0.116E-07	1
0	0.23000000E+00	0	0.132E-07	1
12	0.24000000E+00	0	0.149E-07	1
0	0.25000000E+00	0	0.168E-07	1
13	0.26000000E+00	0	0.178E-07	1
0	0.27000000E+00	0	0.177E-07	1
14	0.28000000E+00	0	0.173E-07	1
0	0.29000000E+00	0	0.171E-07	1
15	0.30000000E+00	0	0.166E-07	1
0	0.31000000E+00	0	0.160E-07	1
16	0.32000000E+00	0	0.159E-07	1
0	0.33000000E+00	0	0.170E-07	1
17	0.34000000E+00	0	0.199E-07	1
0	0.35000000E+00	0	0.248E-07	1
18	0.36000000E+00	0	0.312E-07	1
0	0.37000000E+00	0	0.383E-07	1
19	0.38000000E+00	0	0.450E-07	1
0	0.39000000E+00	0	0.508E-07	1
20	0.40000000E+00	0	0.565E-07	1
0	0.41000000E+00	0	0.631E-07	1
21	0.42000000E+00	0	0.722E-07	1
0	0.43000000E+00	0	0.840E-07	1
22	0.44000000E+00	0	0.971E-07	1
0	0.45000000E+00	0	0.112E-06	1

23	0.46000000E+00	0	0.132E-06	1
0	0.47000000E+00	0	0.158E-06	1
24	0.48000000E+00	0	0.190E-06	1
0	0.49000000E+00	0	0.222E-06	1
25	0.50000000E+00	0	0.245E-06	1
0	0.51000000E+00	0	0.252E-06	1
26	0.52000000E+00	0	0.245E-06	1
0	0.53000000E+00	0	0.227E-06	1
27	0.54000000E+00	0	0.208E-06	1
0	0.55000000E+00	0	0.191E-06	1
28	0.56000000E+00	0	0.177E-06	1
0	0.57000000E+00	0	0.164E-06	1
29	0.58000000E+00	0	0.146E-06	1
0	0.59000000E+00	0	0.123E-06	1
30	0.60000000E+00	0	0.110E-06	1
0	0.61000000E+00	0	0.109E-06	1
31	0.62000000E+00	0	0.110E-06	1
0	0.63000000E+00	0	0.115E-06	1
32	0.64000000E+00	0	0.122E-06	1
0	0.65000000E+00	0	0.129E-06	1
33	0.66000000E+00	0	0.132E-06	1
0	0.67000000E+00	0	0.134E-06	1
34	0.68000000E+00	0	0.137E-06	1
0	0.69000000E+00	0	0.142E-06	1
35	0.70000000E+00	0	0.157E-06	1
0	0.71000000E+00	0	0.171E-06	1
36	0.72000000E+00	0	0.171E-06	1
0	0.73000000E+00	0	0.182E-06	1
37	0.74000000E+00	0	0.193E-06	1
0	0.75000000E+00	0	0.204E-06	1
38	0.76000000E+00	0	0.213E-06	1
0	0.77000000E+00	0	0.224E-06	1
39	0.78000000E+00	0	0.226E-06	1
0	0.79000000E+00	0	0.232E-06	1
40	0.80000000E+00	0	0.239E-06	1
0	0.81000000E+00	0	0.247E-06	1
41	0.82000000E+00	0	0.253E-06	1
0	0.83000000E+00	0	0.266E-06	1
42	0.84000000E+00	0	0.275E-06	1
0	0.85000000E+00	0	0.261E-06	1
43	0.86000000E+00	0	0.262E-06	1
0	0.87000000E+00	0	0.262E-06	1
44	0.88000000E+00	0	0.262E-06	1
0	0.89000000E+00	0	0.260E-06	1
45	0.90000000E+00	0	0.276E-06	1
0	0.91000000E+00	0	0.278E-06	1
46	0.92000000E+00	0	0.261E-06	1
0	0.93000000E+00	0	0.257E-06	1
47	0.94000000E+00	0	0.254E-06	1
0	0.95000000E+00	0	0.248E-06	1
48	0.96000000E+00	0	0.239E-06	1
0	0.97000000E+00	0	0.230E-06	1
49	0.98000000E+00	0	0.217E-06	1
0	0.99000000E+00	0	0.205E-06	1
50	0.10000000E+01	0	0.199E-06	1
0	0.10100000E+01	0	0.200E-06	1
51	0.10200000E+01	0	0.212E-06	1
0	0.10300000E+01	0	0.224E-06	1
52	0.10400000E+01	0	0.243E-06	1
0	0.10500000E+01	0	0.258E-06	1
53	0.10600000E+01	0	0.306E-06	1

0	0.10700000E+01	0	0.354E-06	1
54	0.10800000E+01	0	0.371E-06	1
0	0.10900000E+01	0	0.330E-06	1
55	0.11000000E+01	0	0.276E-06	1
0	0.11100000E+01	0	0.209E-06	1
56	0.11200000E+01	0	0.149E-06	1
0	0.11300000E+01	0	0.104E-06	1
57	0.11400000E+01	0	0.809E-07	1
0	0.11500000E+01	0	0.627E-07	1
58	0.11600000E+01	0	0.381E-07	1
0	0.11700000E+01	0	0.260E-07	1
59	0.11800000E+01	0	0.240E-07	1
0	0.11900000E+01	0	0.266E-07	1
60	0.12000000E+01	0	0.544E-07	1
0	0.12100000E+01	0	0.898E-07	1
61	0.12200000E+01	0	0.973E-07	1
0	0.12300000E+01	0	0.799E-07	1
62	0.12400000E+01	0	0.989E-07	1
0	0.12500000E+01	0	0.116E-06	1
63	0.12600000E+01	0	0.132E-06	1
0	0.12700000E+01	0	0.149E-06	1
64	0.12800000E+01	0	0.172E-06	1
0	0.12900000E+01	0	0.200E-06	1
65	0.13000000E+01	0	0.234E-06	1
0	0.13100000E+01	0	0.269E-06	1
66	0.13200000E+01	0	0.303E-06	1
0	0.13300000E+01	0	0.334E-06	1
67	0.13400000E+01	0	0.366E-06	1
0	0.13500000E+01	0	0.398E-06	1
68	0.13600000E+01	0	0.430E-06	1
0	0.13700000E+01	0	0.462E-06	1
69	0.13800000E+01	0	0.495E-06	1
0	0.13900000E+01	0	0.530E-06	1
70	0.14000000E+01	0	0.564E-06	1
0	0.14100000E+01	0	0.594E-06	1
71	0.14200000E+01	0	0.620E-06	1
0	0.14300000E+01	0	0.647E-06	1
72	0.14400000E+01	0	0.685E-06	1
0	0.14500000E+01	0	0.732E-06	1
73	0.14600000E+01	0	0.788E-06	1
0	0.14700000E+01	0	0.845E-06	1
74	0.14800000E+01	0	0.901E-06	1
0	0.14900000E+01	0	0.948E-06	1
75	0.15000000E+01	0	0.974E-06	1
0	0.15100000E+01	0	0.971E-06	1
76	0.15200000E+01	0	0.941E-06	1
0	0.15300000E+01	0	0.894E-06	1
77	0.15400000E+01	0	0.849E-06	1
0	0.15500000E+01	0	0.810E-06	1
78	0.15600000E+01	0	0.777E-06	1
0	0.15700000E+01	0	0.745E-06	1
79	0.15800000E+01	0	0.709E-06	1
0	0.15900000E+01	0	0.671E-06	1
80	0.16000000E+01	0	0.636E-06	1
0	0.16100000E+01	0	0.606E-06	1
81	0.16200000E+01	0	0.581E-06	1
0	0.16300000E+01	0	0.562E-06	1
82	0.16400000E+01	0	0.548E-06	1
0	0.16500000E+01	0	0.540E-06	1
83	0.16600000E+01	0	0.548E-06	1
0	0.16700000E+01	0	0.577E-06	1

84	0.16800000E+01	0	0.621E-06	1
0	0.16900000E+01	0	0.793E-06	1
85	0.17000000E+01	0	0.105E-05	1
0	0.17100000E+01	0	0.130E-05	1
86	0.17200000E+01	0	0.147E-05	1

```

***** ( SUBDIVISION OF ELEMENT 1 ) *****
*
*NUMBER OF NODES CREATED
*      1
* NOD.NAME      COORD'S (X,Y) RELATIVE TO END(1) OF SUBDIVIDED ELEMENT
* #n1           0.000000E+00           0.333333E+00
*-----*
*
*NUMBER OF ELEMENTS CREATED
*      2
* ELM.NAME      TYPE.OF.ELEMENT      NOD.NAMES
* #e1           cbp2                 1      #n1
* #e2           qdp2                 #n1     3
*-----*
*
*NUMBER OF IMPERFECT ELEMENTS
*      0
*****

```

```

***** ( SUBDIVISION OF ELEMENT 2 ) *****
*
*NUMBER OF NODES CREATED
*      1
* NOD.NAME      COORD'S (X,Y) RELATIVE TO END(1) OF SUBDIVIDED ELEMENT
* #n2           0.000000E+00           0.333333E+00
*-----*
*
*NUMBER OF ELEMENTS CREATED
*      2
* ELM.NAME      TYPE.OF.ELEMENT      NOD.NAMES
* #e3           cbp2                 2      #n2
* #e4           qdp2                 #n2     4
*-----*
*
*NUMBER OF IMPERFECT ELEMENTS
*      0
*****

```

0	0.17300000E+01	0	0.317E-04	1
87	0.17400000E+01	0	0.374E-04	1

```

***** ( SUBDIVISION OF ELEMENT #e2 ) *****
*
*NUMBER OF NODES CREATED
*      1
* NOD.NAME      COORD'S (X,Y) RELATIVE TO END(1) OF SUBDIVIDED ELEMENT
* #n3           0.000000E+00           0.333333E+01
*-----*
*
*NUMBER OF ELEMENTS CREATED
*      2
* ELM.NAME      TYPE.OF.ELEMENT      NOD.NAMES
* #e6           cbp2                 #n3     3
* #e5           qdp2                 #n1     #n3

```

```

*-----*
*
*NUMBER OF IMPERFECT ELEMENTS
*          0
*****

***** ( SUBDIVISION OF ELEMENT #e4 )*****
*
*NUMBER OF NODES CREATED
*          1
* NOD.NAME      COORD'S (X,Y) RELATIVE TO END(1) OF SUBDIVIDED ELEMENT
* #n4            0.000000E+00          0.333333E+01
*-----*
*
*NUMBER OF ELEMENTS CREATED
*          2
* ELM.NAME      TYPE.OF.ELEMENT      NOD.NAMES
* #e8           cbp2                  #n4      4
* #e7           qdp2                  #n2      #n4
*-----*
*
*NUMBER OF IMPERFECT ELEMENTS
*          0
*****

      0          0.17500000E+01      0          0.727E-04          1
      88         0.17600000E+01      0          0.624E-04          1
      0          0.17700000E+01      0          0.327E-04          1

***** ( SUBDIVISION OF ELEMENT #e5 )*****
*
*NUMBER OF NODES CREATED
*          1
* NOD.NAME      COORD'S (X,Y) RELATIVE TO END(1) OF SUBDIVIDED ELEMENT
* #n5            0.000000E+00          0.666667E+00
*-----*
*
*NUMBER OF ELEMENTS CREATED
*          2
* ELM.NAME      TYPE.OF.ELEMENT      NOD.NAMES
* #e9           cbp2                  #n1      #n5
* #e10          qdp2                  #n5      #n3
*-----*
*
*NUMBER OF IMPERFECT ELEMENTS
*          0
*****

***** ( SUBDIVISION OF ELEMENT #e7 )*****
*
*NUMBER OF NODES CREATED
*          1
* NOD.NAME      COORD'S (X,Y) RELATIVE TO END(1) OF SUBDIVIDED ELEMENT
* #n6            0.000000E+00          0.666667E+00
*-----*
*
*NUMBER OF ELEMENTS CREATED
*          2
* ELM.NAME      TYPE.OF.ELEMENT      NOD.NAMES

```

```

* #e11          cbp2          #n2          #n6          *
* #e12          qdp2          #n6          #n4          *
*-----*
*
*NUMBER OF IMPERFECT ELEMENTS          *
*          0          *
*****

```

89	0.17800000E+01	0	0.204E-04	1
0	0.17900000E+01	0	0.230E-04	1
90	0.18000000E+01	0	0.299E-04	1
0	0.18100000E+01	0	0.122E-05	1
91	0.18200000E+01	0	0.201E-05	1
0	0.18300000E+01	0	0.287E-05	1
92	0.18400000E+01	0	0.659E-05	1
0	0.18500000E+01	0	0.993E-06	1
93	0.18600000E+01	0	0.423E-05	1
0	0.18700000E+01	0	0.117E-04	1
94	0.18800000E+01	0	0.658E-06	1
0	0.18900000E+01	0	0.102E-04	1
95	0.19000000E+01	0	0.212E-04	1
0	0.19100000E+01	0	0.115E-04	1
96	0.19200000E+01	0	0.541E-05	1
0	0.19300000E+01	0	0.254E-05	1
97	0.19400000E+01	0	0.322E-05	1
0	0.19500000E+01	0	0.266E-05	1
98	0.19600000E+01	0	0.317E-05	1
0	0.19700000E+01	0	0.370E-05	1
99	0.19800000E+01	0	0.405E-05	1
0	0.19900000E+01	0	0.402E-05	1
100	0.20000000E+01	0	0.373E-05	1
0	0.20100000E+01	0	0.268E-04	1
101	0.20200000E+01	0	0.151E-04	1
0	0.20300000E+01	0	0.357E-05	1
102	0.20400000E+01	0	0.398E-05	1
0	0.20500000E+01	0	0.424E-05	1
103	0.20600000E+01	0	0.435E-05	1
0	0.20700000E+01	0	0.437E-05	1
104	0.20800000E+01	0	0.442E-05	1
0	0.20900000E+01	0	0.464E-05	1
105	0.21000000E+01	0	0.496E-05	1
0	0.21100000E+01	0	0.521E-05	1
106	0.21200000E+01	0	0.532E-05	1
0	0.21300000E+01	0	0.525E-05	1
107	0.21400000E+01	0	0.505E-05	1
0	0.21500000E+01	0	0.478E-05	1
108	0.21600000E+01	0	0.447E-05	1
0	0.21700000E+01	0	0.423E-05	1
109	0.21800000E+01	0	0.410E-05	1
0	0.21900000E+01	0	0.399E-05	1
110	0.22000000E+01	0	0.377E-05	1
0	0.22100000E+01	0	0.343E-05	1
111	0.22200000E+01	0	0.308E-05	1

```

***** ( SUBDIVISION OF ELEMENT 5 ) *****
*
*NUMBER OF NODES CREATED          *
*          2          *
* NOD.NAME          COORD'S (X,Y) RELATIVE TO END(1) OF SUBDIVIDED ELEMENT *
* #n7          0.500000E+00          0.000000E+00          *
* #n8          0.550000E+01          0.000000E+00          *

```

```

*-----*
*
*NUMBER OF ELEMENTS CREATED
*          3
* ELM.NAME   TYPE.OF.ELEMENT   NOD.NAMES
* #e13       cbp2              3          #n7
* #e15       cbp2              #n8         4
* #e14       qdp2              #n7         #n8
*-----*
*
*NUMBER OF IMPERFECT ELEMENTS
*          0
*****
          0          0.22300000E+01          0          0.809E-05          1
*****
***** ( SUBDIVISION OF ELEMENT 3 ) *****
*
*NUMBER OF NODES CREATED
*          1
* NOD.NAME   COORD'S (X,Y) RELATIVE TO END(1) OF SUBDIVIDED ELEMENT
* #n9        0.000000E+00          0.366667E+01
*-----*
*
*NUMBER OF ELEMENTS CREATED
*          2
* ELM.NAME   TYPE.OF.ELEMENT   NOD.NAMES
* #e17       cbp2              #n9         5
* #e16       qdp2              3          #n9
*-----*
*
*NUMBER OF IMPERFECT ELEMENTS
*          0
*****
***** ( SUBDIVISION OF ELEMENT 4 ) *****
*
*NUMBER OF NODES CREATED
*          1
* NOD.NAME   COORD'S (X,Y) RELATIVE TO END(1) OF SUBDIVIDED ELEMENT
* #n10       0.000000E+00          0.366667E+01
*-----*
*
*NUMBER OF ELEMENTS CREATED
*          2
* ELM.NAME   TYPE.OF.ELEMENT   NOD.NAMES
* #e19       cbp2              #n10        6
* #e18       qdp2              4          #n10
*-----*
*
*NUMBER OF IMPERFECT ELEMENTS
*          0
*****
***** ( SUBDIVISION OF ELEMENT 6 ) *****
*
*NUMBER OF NODES CREATED
*          2
* NOD.NAME   COORD'S (X,Y) RELATIVE TO END(1) OF SUBDIVIDED ELEMENT

```

```

* #n11          0.500000E+00          0.000000E+00          *
* #n12          0.550000E+01          0.000000E+00          *
*-----*
*
*NUMBER OF ELEMENTS CREATED          *
*          3                          *
* ELM.NAME      TYPE.OF.ELEMENT      NOD.NAMES          *
* #e20          cbp2                  5          #n11          *
* #e22          cbp2                  #n12         6          *
* #e21          qdp2                  #n11         #n12          *
*-----*
*
*NUMBER OF IMPERFECT ELEMENTS          *
*          0                          *
*****
112          0.22400000E+01          0          0.608E-05          1

***** ( SUBDIVISION OF ELEMENT #e16 ) *****
*
*NUMBER OF NODES CREATED          *
*          1                          *
* NOD.NAME      COORD'S (X,Y) RELATIVE TO END(1) OF SUBDIVIDED ELEMENT *
* #n13          0.000000E+00          0.333333E+00          *
*-----*
*
*NUMBER OF ELEMENTS CREATED          *
*          2                          *
* ELM.NAME      TYPE.OF.ELEMENT      NOD.NAMES          *
* #e23          cbp2                  3          #n13          *
* #e24          qdp2                  #n13         #n9          *
*-----*
*
*NUMBER OF IMPERFECT ELEMENTS          *
*          0                          *
*****

***** ( SUBDIVISION OF ELEMENT #e18 ) *****
*
*NUMBER OF NODES CREATED          *
*          1                          *
* NOD.NAME      COORD'S (X,Y) RELATIVE TO END(1) OF SUBDIVIDED ELEMENT *
* #n14          0.000000E+00          0.333333E+00          *
*-----*
*
*NUMBER OF ELEMENTS CREATED          *
*          2                          *
* ELM.NAME      TYPE.OF.ELEMENT      NOD.NAMES          *
* #e25          cbp2                  4          #n14          *
* #e26          qdp2                  #n14         #n10          *
*-----*
*
*NUMBER OF IMPERFECT ELEMENTS          *
*          0                          *
*****

0          0.22500000E+01          0          0.183E-04          1
113         0.22600000E+01          0          0.814E-05          1
0          0.22700000E+01          0          0.951E-05          1
114         0.22800000E+01          0          0.257E-04          1

```

0	0.22900000E+01	0	0.200E-04	1
115	0.23000000E+01	0	0.248E-04	1
0	0.23100000E+01	0	0.325E-04	1
116	0.23200000E+01	0	0.216E-04	1

```

***** ( SUBDIVISION OF ELEMENT #e24 ) *****
*
*NUMBER OF NODES CREATED
*      1
* NOD.NAME      COORD'S (X,Y) RELATIVE TO END(1) OF SUBDIVIDED ELEMENT
* #n15          0.000000E+00          0.666667E+00
*-----*
*
*NUMBER OF ELEMENTS CREATED
*      2
* ELM.NAME      TYPE.OF.ELEMENT      NOD.NAMES
* #e27          cbp2          #n13      #n15
* #e28          qdp2          #n15      #n9
*-----*
*
*NUMBER OF IMPERFECT ELEMENTS
*      0
*****

```

```

***** ( SUBDIVISION OF ELEMENT #e26 ) *****
*
*NUMBER OF NODES CREATED
*      1
* NOD.NAME      COORD'S (X,Y) RELATIVE TO END(1) OF SUBDIVIDED ELEMENT
* #n16          0.000000E+00          0.666667E+00
*-----*
*
*NUMBER OF ELEMENTS CREATED
*      2
* ELM.NAME      TYPE.OF.ELEMENT      NOD.NAMES
* #e29          cbp2          #n14      #n16
* #e30          qdp2          #n16      #n10
*-----*
*
*NUMBER OF IMPERFECT ELEMENTS
*      0
*****

```

0	0.23300000E+01	0	0.115E-04	1
117	0.23400000E+01	0	0.251E-04	1
0	0.23500000E+01	0	0.191E-04	1
118	0.23600000E+01	0	0.307E-04	1
0	0.23700000E+01	0	0.562E-05	1

```

***** ( SUBDIVISION OF ELEMENT #e30 ) *****
*
*NUMBER OF NODES CREATED
*      1
* NOD.NAME      COORD'S (X,Y) RELATIVE TO END(1) OF SUBDIVIDED ELEMENT
* #n17          0.000000E+00          0.200000E+01
*-----*
*
*NUMBER OF ELEMENTS CREATED
*      2
* ELM.NAME      TYPE.OF.ELEMENT      NOD.NAMES

```

```

* #e32          cbp2          #n17          #n10          *
* #e31          qdp2          #n16          #n17          *
*-----*
*
*NUMBER OF IMPERFECT ELEMENTS          *
*          0          *
*****
***** ( SUBDIVISION OF ELEMENT #e21 ) *****
*
*NUMBER OF NODES CREATED          *
*          1          *
* NOD.NAME          COORD'S (X,Y) RELATIVE TO END(1) OF SUBDIVIDED ELEMENT *
* #n18          0.100000E+01          0.000000E+00          *
*-----*
*
*NUMBER OF ELEMENTS CREATED          *
*          2          *
* ELM.NAME          TYPE.OF.ELEMENT          NOD.NAMES          *
* #e33          cbp2          #n11          #n18          *
* #e34          qdp2          #n18          #n12          *
*-----*
*
*NUMBER OF IMPERFECT ELEMENTS          *
*          0          *
*****
119          0.23800000E+01          0          0.148E-04          1
***** ( SUBDIVISION OF ELEMENT #e34 ) *****
*
*NUMBER OF NODES CREATED          *
*          1          *
* NOD.NAME          COORD'S (X,Y) RELATIVE TO END(1) OF SUBDIVIDED ELEMENT *
* #n19          0.300000E+01          0.000000E+00          *
*-----*
*
*NUMBER OF ELEMENTS CREATED          *
*          2          *
* ELM.NAME          TYPE.OF.ELEMENT          NOD.NAMES          *
* #e36          cbp2          #n19          #n12          *
* #e35          qdp2          #n18          #n19          *
*-----*
*
*NUMBER OF IMPERFECT ELEMENTS          *
*          0          *
*****
0          0.23900000E+01          0          0.838E-05          1
***** ( SUBDIVISION OF ELEMENT #e28 ) *****
*
*NUMBER OF NODES CREATED          *
*          1          *
* NOD.NAME          COORD'S (X,Y) RELATIVE TO END(1) OF SUBDIVIDED ELEMENT *
* #n20          0.000000E+00          0.200000E+01          *
*-----*
*
*NUMBER OF ELEMENTS CREATED          *
*          2          *

```

```

* ELM.NAME      TYPE.OF.ELEMENT      NOD.NAMES
* #e38          cbp2          #n20      #n9
* #e37          qdp2          #n15      #n20

```

```

*-----*

```

```

*

```

```

*NUMBER OF IMPERFECT ELEMENTS

```

```

*          0

```

```

*****

```

120	0.24000000E+01	0	0.323E-05	1
0	0.24100000E+01	0	0.379E-05	1
121	0.24200000E+01	0	0.422E-05	1
0	0.24300000E+01	0	0.319E-05	1
122	0.24400000E+01	0	0.667E-06	1
0	0.24500000E+01	0	0.412E-05	1
123	0.24600000E+01	0	0.515E-05	1
0	0.24700000E+01	0	0.527E-06	1
124	0.24800000E+01	0	0.492E-05	1
0	0.24900000E+01	0	0.217E-04	1
125	0.25000000E+01	0	0.531E-06	1
0	0.25100000E+01	0	0.515E-06	1
126	0.25200000E+01	0	0.562E-06	1
0	0.25300000E+01	0	0.546E-06	1
127	0.25400000E+01	0	0.760E-06	1
0	0.25500000E+01	0	0.917E-06	1
128	0.25600000E+01	0	0.101E-05	1
0	0.25700000E+01	0	0.136E-05	1
129	0.25800000E+01	0	0.187E-05	1
0	0.25900000E+01	0	0.186E-05	1
130	0.26000000E+01	0	0.198E-05	1
0	0.26100000E+01	0	0.225E-05	1
131	0.26200000E+01	0	0.262E-05	1
0	0.26300000E+01	0	0.306E-05	1
132	0.26400000E+01	0	0.324E-05	1
0	0.26500000E+01	0	0.332E-05	1
133	0.26600000E+01	0	0.370E-05	1
0	0.26700000E+01	0	0.410E-05	1
134	0.26800000E+01	0	0.421E-05	1
0	0.26900000E+01	0	0.435E-05	1
135	0.27000000E+01	0	0.464E-05	1
0	0.27100000E+01	0	0.477E-05	1
136	0.27200000E+01	0	0.477E-05	1
0	0.27300000E+01	0	0.491E-05	1
137	0.27400000E+01	0	0.481E-05	1
0	0.27500000E+01	0	0.446E-05	1
138	0.27600000E+01	0	0.433E-05	1
0	0.27700000E+01	0	0.451E-05	1
139	0.27800000E+01	0	0.484E-05	1
0	0.27900000E+01	0	0.503E-05	1
140	0.28000000E+01	0	0.469E-05	1
0	0.28100000E+01	0	0.393E-05	1
141	0.28200000E+01	0	0.353E-05	1
0	0.28300000E+01	0	0.356E-05	1
142	0.28400000E+01	0	0.379E-05	1
0	0.28500000E+01	0	0.387E-05	1
143	0.28600000E+01	0	0.370E-05	1
0	0.28700000E+01	0	0.344E-05	1
144	0.28800000E+01	0	0.317E-05	1
0	0.28900000E+01	0	0.292E-05	1
145	0.29000000E+01	0	0.276E-05	1
0	0.29100000E+01	0	0.271E-05	1

146	0.29200000E+01	0	0.270E-05	1
0	0.29300000E+01	0	0.253E-05	1
147	0.29400000E+01	0	0.240E-05	1
0	0.29500000E+01	0	0.250E-05	1
148	0.29600000E+01	0	0.410E-05	1
0	0.29700000E+01	0	0.113E-04	1
149	0.29800000E+01	0	0.191E-05	1
0	0.29900000E+01	0	0.153E-05	1
150	0.30000000E+01	0	0.152E-04	1
0	0.30100000E+01	0	0.146E-05	1
151	0.30200000E+01	0	0.590E-05	1
0	0.30300000E+01	0	0.722E-05	1
152	0.30400000E+01	0	0.531E-04	1
0	0.30500000E+01	0	0.745E-05	1
153	0.30600000E+01	0	0.417E-06	1
0	0.30700000E+01	0	0.315E-06	1
154	0.30800000E+01	0	0.273E-06	1
0	0.30900000E+01	0	0.270E-05	1
155	0.31000000E+01	0	0.627E-07	1
0	0.31100000E+01	0	0.102E-04	1
156	0.31200000E+01	0	0.124E-06	1
0	0.31300000E+01	0	0.136E-06	1
157	0.31400000E+01	0	0.121E-06	1
0	0.31500000E+01	0	0.147E-06	1
158	0.31600000E+01	0	0.241E-06	1
0	0.31700000E+01	0	0.410E-06	1
159	0.31800000E+01	0	0.712E-06	1
0	0.31900000E+01	0	0.104E-05	1
160	0.32000000E+01	0	0.121E-05	1
0	0.32100000E+01	0	0.117E-05	1
161	0.32200000E+01	0	0.124E-05	1
0	0.32300000E+01	0	0.146E-05	1
162	0.32400000E+01	0	0.185E-05	1
0	0.32500000E+01	0	0.218E-05	1
163	0.32600000E+01	0	0.222E-05	1
0	0.32700000E+01	0	0.219E-05	1
164	0.32800000E+01	0	0.228E-05	1
0	0.32900000E+01	0	0.225E-05	1
165	0.33000000E+01	0	0.225E-05	1
0	0.33100000E+01	0	0.240E-05	1
166	0.33200000E+01	0	0.253E-05	1
0	0.33300000E+01	0	0.251E-05	1
167	0.33400000E+01	0	0.239E-05	1
0	0.33500000E+01	0	0.225E-05	1
168	0.33600000E+01	0	0.215E-05	1
0	0.33700000E+01	0	0.205E-05	1
169	0.33800000E+01	0	0.183E-05	1
0	0.33900000E+01	0	0.155E-05	1
170	0.34000000E+01	0	0.140E-05	1
0	0.34100000E+01	0	0.135E-05	1
171	0.34200000E+01	0	0.126E-05	1
0	0.34300000E+01	0	0.116E-05	1
172	0.34400000E+01	0	0.106E-05	1
0	0.34500000E+01	0	0.104E-05	1
173	0.34600000E+01	0	0.103E-05	1
0	0.34700000E+01	0	0.960E-06	1
174	0.34800000E+01	0	0.928E-06	1
0	0.34900000E+01	0	0.997E-06	1
175	0.35000000E+01	0	0.878E-06	1
0	0.35100000E+01	0	0.692E-06	1
176	0.35200000E+01	0	0.679E-06	1

0	0.35300000E+01	0	0.579E-06	1
177	0.35400000E+01	0	0.585E-06	1
0	0.35500000E+01	0	0.668E-06	1
178	0.35600000E+01	0	0.768E-06	1
0	0.35700000E+01	0	0.591E-06	1
179	0.35800000E+01	0	0.468E-06	1
0	0.35900000E+01	0	0.439E-06	1
180	0.36000000E+01	0	0.404E-06	1
0	0.36100000E+01	0	0.504E-06	1
181	0.36200000E+01	0	0.607E-06	1
0	0.36300000E+01	0	0.677E-06	1
182	0.36400000E+01	0	0.757E-06	1
0	0.36500000E+01	0	0.756E-06	1
183	0.36600000E+01	0	0.776E-06	1
0	0.36700000E+01	0	0.906E-06	1
184	0.36800000E+01	0	0.250E-04	1
0	0.36900000E+01	0	0.914E-06	1
185	0.37000000E+01	0	0.124E-05	1
0	0.37100000E+01	0	0.338E-04	1
186	0.37200000E+01	0	0.140E-05	1
0	0.37300000E+01	0	0.236E-04	1
187	0.37400000E+01	0	0.424E-04	1
0	0.37500000E+01	0	0.134E-04	1
188	0.37600000E+01	0	0.344E-04	1
0	0.37700000E+01	0	0.188E-05	1
189	0.37800000E+01	0	0.141E-05	1
0	0.37900000E+01	0	0.165E-05	1
190	0.38000000E+01	0	0.250E-04	1
0	0.38100000E+01	0	0.345E-05	1
191	0.38200000E+01	0	0.140E-04	1
0	0.38300000E+01	0	0.621E-05	1
192	0.38400000E+01	0	0.375E-05	1
0	0.38500000E+01	0	0.647E-05	1
193	0.38600000E+01	0	0.464E-05	1
0	0.38700000E+01	0	0.472E-05	1
194	0.38800000E+01	0	0.523E-05	1
0	0.38900000E+01	0	0.280E-04	1
195	0.39000000E+01	0	0.197E-04	1
0	0.39100000E+01	0	0.566E-05	1
196	0.39200000E+01	0	0.627E-05	1
0	0.39300000E+01	0	0.649E-05	1
197	0.39400000E+01	0	0.625E-05	1
0	0.39500000E+01	0	0.581E-05	1
198	0.39600000E+01	0	0.616E-05	1
0	0.39700000E+01	0	0.621E-05	1
199	0.39800000E+01	0	0.626E-05	1
0	0.39900000E+01	0	0.639E-05	1
200	0.40000000E+01	0	0.644E-05	1
0	0.40100000E+01	0	0.632E-05	1
201	0.40200000E+01	0	0.607E-05	1
0	0.40300000E+01	0	0.577E-05	1
202	0.40400000E+01	0	0.552E-05	1
0	0.40500000E+01	0	0.515E-05	1
203	0.40600000E+01	0	0.463E-05	1
0	0.40700000E+01	0	0.436E-05	1
204	0.40800000E+01	0	0.439E-05	1
0	0.40900000E+01	0	0.433E-05	1
205	0.41000000E+01	0	0.381E-05	1
0	0.41100000E+01	0	0.382E-04	1
206	0.41200000E+01	0	0.334E-05	1
0	0.41300000E+01	0	0.962E-04	1

207	0.41400000E+01	0	0.601E-04	1
0	0.41500000E+01	0	0.369E-05	1
208	0.41600000E+01	0	0.312E-04	1
0	0.41700000E+01	0	0.359E-04	1
209	0.41800000E+01	0	0.138E-04	1
0	0.41900000E+01	0	0.165E-04	1
210	0.42000000E+01	0	0.255E-04	1
0	0.42100000E+01	0	0.616E-05	1
211	0.42200000E+01	0	0.495E-05	1
0	0.42300000E+01	0	0.145E-04	1
212	0.42400000E+01	0	0.721E-05	1
0	0.42500000E+01	0	0.510E-05	1
213	0.42600000E+01	0	0.287E-04	1
0	0.42700000E+01	0	0.544E-05	1
214	0.42800000E+01	0	0.776E-05	1
0	0.42900000E+01	0	0.107E-04	1
215	0.43000000E+01	0	0.259E-04	1
0	0.43100000E+01	0	0.139E-04	1
216	0.43200000E+01	0	0.405E-04	1
0	0.43300000E+01	0	0.139E-04	1
217	0.43400000E+01	0	0.116E-04	1

***** (SUBDIVISION OF ELEMENT #e14)*****

* * * * *

*NUMBER OF NODES CREATED * *

* 2 * *

* NOD.NAME COORD'S (X,Y) RELATIVE TO END(1) OF SUBDIVIDED ELEMENT * *

* #n21 0.100000E+01 0.000000E+00 * *

* #n22 0.400000E+01 0.000000E+00 * *

----- *

* * * * *

*NUMBER OF ELEMENTS CREATED * *

* 3 * *

* ELM.NAME TYPE.OF.ELEMENT NOD.NAMES * *

* #e39 cbp2 #n7 #n21 * *

* #e41 cbp2 #n22 #n8 * *

* #e40 qdp2 #n21 #n22 * *

----- *

* * * * *

*NUMBER OF IMPERFECT ELEMENTS * *

* 0 * *

0	0.43500000E+01	0	0.253E-04	1
218	0.43600000E+01	0	0.844E-05	1
0	0.43700000E+01	0	0.258E-04	1
219	0.43800000E+01	0	0.280E-04	1
0	0.43900000E+01	0	0.492E-05	2
220	0.44000000E+01	0	0.956E-04	1
0	0.44100000E+01	0	0.657E-04	1
221	0.44200000E+01	0	0.168E-04	1
0	0.44300000E+01	0	0.231E-04	1
222	0.44400000E+01	0	0.218E-04	1
0	0.44500000E+01	0	0.181E-04	1
223	0.44600000E+01	0	0.190E-04	1
0	0.44700000E+01	0	0.463E-04	1
224	0.44800000E+01	0	0.983E-05	1
0	0.44900000E+01	0	0.137E-04	1
225	0.45000000E+01	0	0.326E-04	1
0	0.45100000E+01	0	0.339E-04	1
226	0.45200000E+01	0	0.130E-04	1

0	0.45300000E+01	0	0.143E-04	1
227	0.45400000E+01	0	0.412E-05	1
0	0.45500000E+01	0	0.177E-05	1
228	0.45600000E+01	0	0.160E-05	1
0	0.45700000E+01	0	0.261E-05	1
229	0.45800000E+01	0	0.353E-05	1
0	0.45900000E+01	0	0.127E-04	1
230	0.46000000E+01	0	0.126E-04	1
0	0.46100000E+01	0	0.406E-06	1
231	0.46200000E+01	0	0.135E-05	1
0	0.46300000E+01	0	0.560E-04	1
232	0.46400000E+01	0	0.954E-05	1
0	0.46500000E+01	0	0.691E-06	1
233	0.46600000E+01	0	0.327E-04	1
0	0.46700000E+01	0	0.215E-04	1
234	0.46800000E+01	0	0.927E-05	1
0	0.46900000E+01	0	0.492E-05	1
235	0.47000000E+01	0	0.192E-04	1
0	0.47100000E+01	0	0.181E-04	1
236	0.47200000E+01	0	0.403E-04	1
0	0.47300000E+01	0	0.225E-04	1
237	0.47400000E+01	0	0.831E-05	1
0	0.47500000E+01	0	0.135E-04	1
238	0.47600000E+01	0	0.316E-05	1
0	0.47700000E+01	0	0.132E-04	1
239	0.47800000E+01	0	0.456E-04	1
0	0.47900000E+01	0	0.689E-05	1
240	0.48000000E+01	0	0.684E-05	1
0	0.48100000E+01	0	0.460E-04	1
241	0.48200000E+01	0	0.436E-04	1
0	0.48300000E+01	0	0.520E-05	1
242	0.48400000E+01	0	0.196E-04	1
0	0.48500000E+01	0	0.443E-04	1
243	0.48600000E+01	0	0.218E-04	1
0	0.48700000E+01	0	0.104E-04	1
244	0.48800000E+01	0	0.256E-04	1
0	0.48900000E+01	0	0.252E-04	1
245	0.49000000E+01	0	0.317E-04	1

***** (SUBDIVISION OF ELEMENT #e12)*****

* * * * *

*NUMBER OF NODES CREATED * * * * *

* 1 * * * * *

* NOD.NAME COORD'S (X,Y) RELATIVE TO END(1) OF SUBDIVIDED ELEMENT * * * * *

* #n23 0.000000E+00 0.200000E+01 * * * * *

----- * * * *

* * * * *

*NUMBER OF ELEMENTS CREATED * * * * *

* 2 * * * * *

* ELM.NAME TYPE.OF.ELEMENT NOD.NAMES * * * * *

* #e43 cbp2 #n23 #n4 * * * * *

* #e42 qdp2 #n6 #n23 * * * * *

----- * * * *

* * * * *

*NUMBER OF IMPERFECT ELEMENTS * * * * *

* 0 * * * * *

0	0.49100000E+01	0	0.196E-04	1
---	----------------	---	-----------	---

***** (SUBDIVISION OF ELEMENT #e10)*****

```

*
*NUMBER OF NODES CREATED
*
*      1
* NOD.NAME      COORD'S (X,Y) RELATIVE TO END(1) OF SUBDIVIDED ELEMENT
* #n24          0.000000E+00          0.200000E+01
*-----*
*
*NUMBER OF ELEMENTS CREATED
*
*      2
* ELM.NAME      TYPE.OF.ELEMENT      NOD.NAMES
* #e45          cbp2                  #n24      #n3
* #e44          qdp2                  #n5       #n24
*-----*
*
*NUMBER OF IMPERFECT ELEMENTS
*
*      0
*****
246      0.49200000E+01      0      0.305E-04      1
  0      0.49300000E+01      0      0.293E-04      1
247      0.49400000E+01      0      0.583E-04      1
  0      0.49500000E+01      0      0.302E-04      1
248      0.49600000E+01      0      0.570E-04      1
  0      0.49700000E+01      0      0.424E-04      1
249      0.49800000E+01      0      0.915E-04      1
  0      0.49900000E+01      0      0.156E-04      1
250      0.50000000E+01      0      0.434E-04      1

```

9.6 Steel frame subject to explosion and fire loading

This example illustrates the considerable influence of explosion on the fire resistance of steel frames, even when the extent of structural damage due to explosion is relative small.

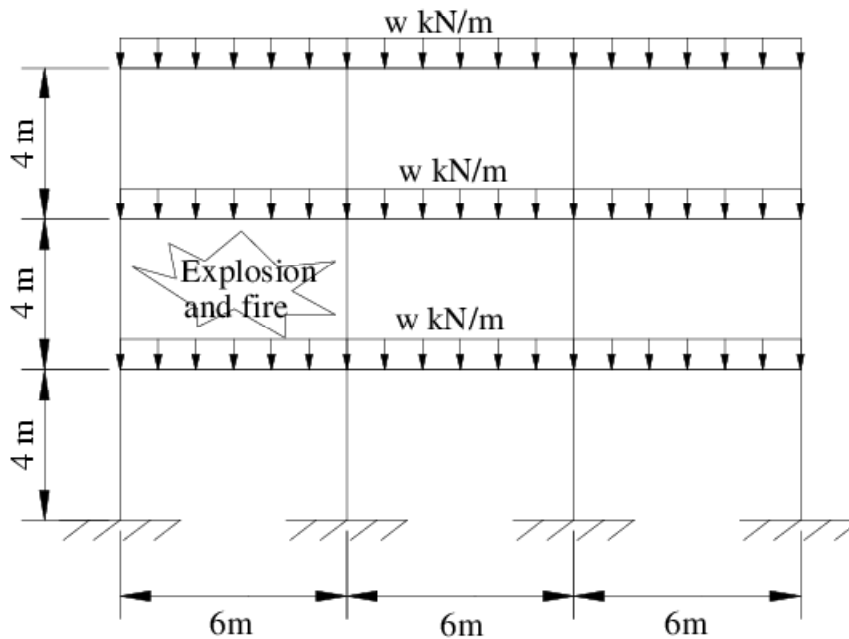

Figure 9.6 Steel frames subject to explosion and fire loading.

There are going to be used elasto-plastic cubic elements to resolve this example. The material model of steel used in this example covers the effects of the elevated temperature, creep and high strain-rate.

9.6.1 Data file

```
# Here temperatures are incremental over ambient temperature (20C)
#
analysis 2d dynamics (a)
#
materials (b)
mat.name      model      properties
  mat1        stl8      31.19 4.65e-3 20 &
                2.1e5 0.84e5 80. 680. 1080. &
                399. 59.9 280. 680. 980. &
                0.0 0.032 280. 380. 880. &
                0.01022 0.01652 730. 731. 1180.

#
sections (c)
  type = isec
mat.name = mat1
  sec.name      dimensions
  sec1          254.5 21.0 254.5 21.0 645.6 13.2
  sec2          152.4 6.8 152.4 6.8 138.8 6.1
  sec3          203.2 11.0 203.2 11.0 181.2 7.3

#
patterns (p)
pat.name      ratios
  pat1         1 1 1 1 1 1 1 1 1 1

#
groups (d)
type = cbp2
  grp.name      sec.name      monitoring.points
  grp1c         sec1          40
  grp2c         sec2          40
  grp3c         sec3          40
type = gdp2
  grp.name      cbp2.grp.name  pat.name
  grp1          grp1c         pat1
  grp2          grp2c         pat1
  grp3          grp3c         pat1

#
type = cnm2
  grp.name      mass
  gpm1          23.4
  gpm2          46.8

#
structural.nodal (e)
  nod.name      x      y
  f 101         0.0    0.0
  r 10          0.0    4000.0 3
  r 100         6000.0 0.0 3

#
restraints (g)
  nod.name      direction
  f 101         x+y+rz
  r 100         -      3

#
element.connectivity (h)
elm.name      grp.name      nod.name
  f 101       grp1         111 211
  r 1         -           100 100 2
  r 3         -           10 10 2

#
```

```

elm.name  grp.name  nod.name
f 201     grp2      101 111
r 1       -        10  10  2
r 3       -        300 300 1
#
elm.name  grp.name  nod.name
f 301     grp3      201 211
r 1       -        10  10  2
r 3       -        100 100 1
#
grp.name = gpm1
elm.name  nod.name
f 1101    111
r 1       10  2
r 3       300 1
#
grp.name = gpm2
elm.name  nod.name
f 1201    211
r 1       10  2
r 3       100 1
#
linear.curves # curves for time history loads
start.time = 18
crv.name = c1
      time  load.factor
      18.12 1.0
      18.15 0.0
      1220  0.0
crv.name = c2
      time  load.factor
      20    0.0
      1220  1.2
#
applied.loading
initial.load
elm.name  type  value
f 101     udl1  0 -75
r 1       -    0  0  2
r 3       -    0  0  2
#
dynamic.load
elm.name  type  crv.name  value
101      udl1  c1        0 -125
104      udl1  c1        0 125
202      udl1  c1       -125 0
302      udl1  c1        125 0
elm.name  type  crv.name  value
104      tmp2  c2      875 -0.3636  875 -0.3636  875 -0.3636
202      tmp2  c2     375 -1.6404  375 -1.6404  375 -1.6404
302      tmp2  c2    1000 0      1000 0      1000 0
equilibrium.stages
      end.of.stage  steps
      18.2         50
      20           45
      640          62
      670          30
#
integration
scheme = hilber
alpha = -0.3

```

[\(g\)](#)

[\(i\)](#)

```

beta = 1.21
gamma = 0.8
#
iterative
number = 10
initial = 10
step = 10
dive = 10
maxi = 0.1e8
#
convergence.criteria (1)
tolerance = 0.5e-3
force.ref = 300e3
moment.ref = 300e6
#
output (m)
frequency 2
#
end

```

Note The following picture shows the names that have been given to the nodes and elements in the data file.

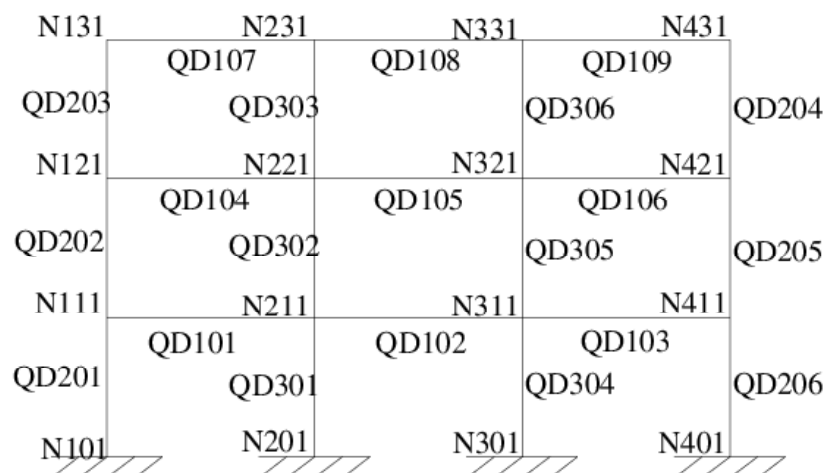
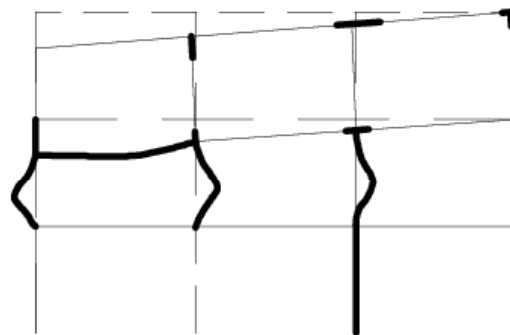

figure 9.6.1 Nodes and elements .

9.6.2 Structural behaviour

This example illustrates the considerable influence of explosion on the fire resistance of steel frames, even when the extent of structural damage due to explosion is relative small.

For both loading scenarios, elevated temperatures initiate buckling in the internal column at $T \approx 475^\circ\text{C}$. However, the explosion/fire scenario is associated with a much reduced overall fire resistance of ($T \approx 642^\circ\text{C}$) in comparison with that of the fire only scenario ($T \approx 894^\circ\text{C}$), representing a reduction of 28%. This reduction is mainly attributed to deterioration in vertical resistance of the side column due to explosion damage, leading to redistribution of vertical loading to the internal column and an earlier overall failure of the system. The deflected shapes for the two loading scenarios are shown in the following figure.



(a) fire loading

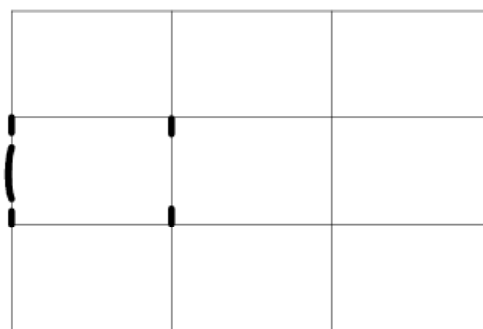

(b) explosion loading

figure 9.6.2a Final deflected shape after: (a) fire loading: (b) explosion.

The deformed shape if we consider explosion and fire loading given by ADAPTIC shows that the combination of both efforts.

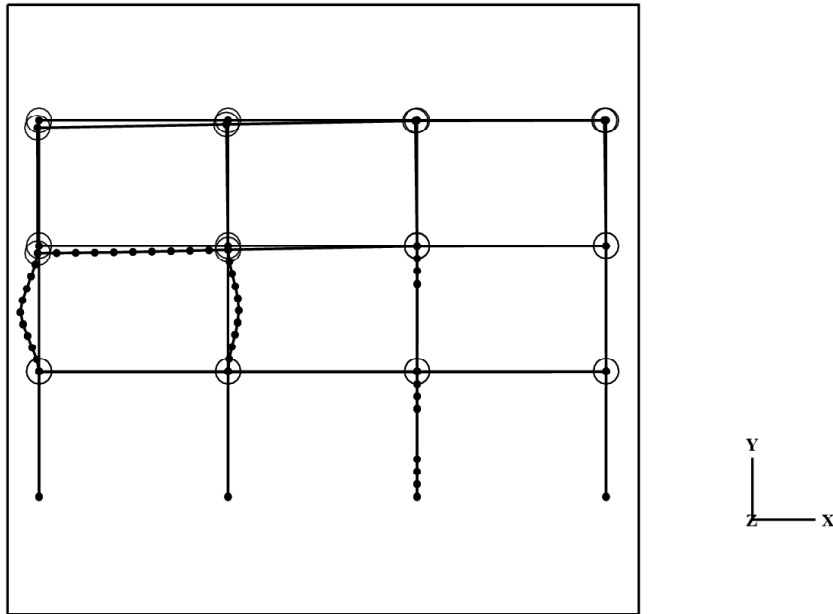

figure 9.6.2b Final deflected shape after explosion and fire loading.

In addition to the analysis of the structure it is going to be considered the CPU time demand over the displacements at the node 121, which is the one that experiments higher displacements.

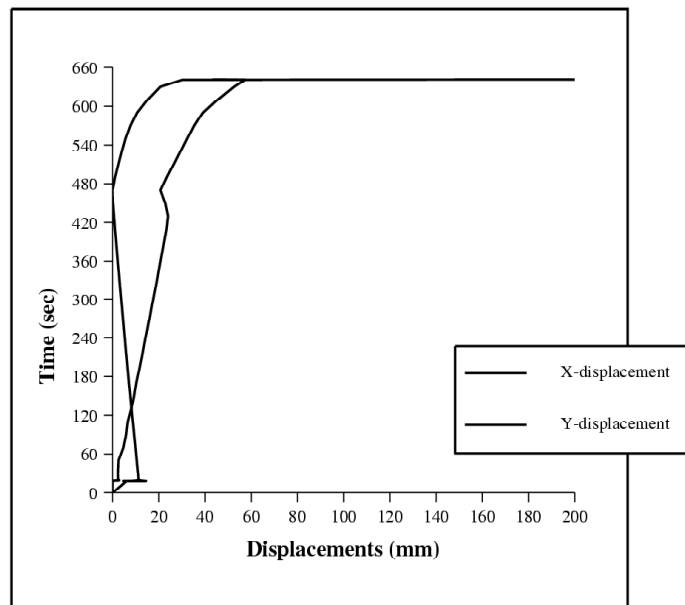

figure 9.6.2b Final deflected shape after explosion and fire loading.

9.6.3 Output file

```

ELEMENT ASSEMBLY ORDER
----->>>> ----->>>> ----->>>> ----->>>> ----->>>> ----->>>> ----->>>>
201      101      202      1101      104      203      1102      107
1103     105     302     303     1202     108     1203     109
306     1206     206     1106     106     305     1205     102
301     1201     205     1105     103     304     1204     204
1104

```

```

MAXIMUM FRONT: (NODAL =      6) - (ADDITIONAL FREEDOMS =      0)
+++++++

```

```

      I N I T I A L   L O A D I N G
      ++++++

```

OUTPUT ITERATIONS	INITIAL LOADING FACTOR	CURRENT TIME	LEVEL	CONV.-NORM	
1	0.10000000E+01	0.18000000E+02	0	0.498E-07	1

```

      V A R I A B L E   L O A D I N G
      ++++++

```

OUTPUT	CURRENT TIME	LEVEL	CONV.-NORM	ITERATIONS
0	0.18004000E+02	0	0.595E-05	0
2	0.18008000E+02	0	0.619E-05	0
0	0.18012000E+02	0	0.663E-05	0
3	0.18016000E+02	0	0.728E-05	0
0	0.18020000E+02	0	0.795E-05	0
4	0.18024000E+02	0	0.841E-05	0
0	0.18028000E+02	0	0.856E-05	0
5	0.18032000E+02	0	0.843E-05	0

```

***** ( SUBDIVISION OF ELEMENT 202 ) *****
*
*NUMBER OF NODES CREATED
*      1
* NOD.NAME      COORD'S (X,Y) RELATIVE TO END(1) OF SUBDIVIDED ELEMENT
* #n1           0.000000E+00           0.400000E+03
*-----*
*
*NUMBER OF ELEMENTS CREATED
*      2
* ELM.NAME      TYPE.OF.ELEMENT      NOD.NAMES
* #e1           cbp2                 111      #n1
* #e2           qdp2                 #n1      121
*-----*
*
*NUMBER OF IMPERFECT ELEMENTS
*      0
*****

```

0	0.18036000E+02	0	0.140E-03	0
6	0.18040000E+02	0	0.652E-05	1
0	0.18044000E+02	0	0.110E-05	1

```

***** ( SUBDIVISION OF ELEMENT #e2 ) *****
*
*NUMBER OF NODES CREATED
*
*      1
* NOD.NAME      COORD'S (X,Y) RELATIVE TO END(1) OF SUBDIVIDED ELEMENT
* #n2           0.000000E+00          0.320000E+04
*-----*
*
*NUMBER OF ELEMENTS CREATED
*
*      2
* ELM.NAME      TYPE.OF.ELEMENT      NOD.NAMES
* #e4           cbp2                 #n2      121
* #e3           qdp2                 #n1      #n2
*-----*
*
*NUMBER OF IMPERFECT ELEMENTS
*
*      0
*****

```

7	0.18048000E+02	0	0.168E-04	1
0	0.18052000E+02	0	0.367E-04	1
8	0.18056000E+02	0	0.155E-03	1
0	0.18060000E+02	0	0.157E-03	1
9	0.18064000E+02	0	0.408E-03	1
0	0.18068000E+02	0	0.233E-05	2
10	0.18072000E+02	0	0.100E-04	2

```

***** ( SUBDIVISION OF ELEMENT #e3 ) *****
*
*NUMBER OF NODES CREATED
*
*      3
* NOD.NAME      COORD'S (X,Y) RELATIVE TO END(1) OF SUBDIVIDED ELEMENT
* #n3           0.000000E+00          0.120000E+04
* #n4           0.000000E+00          0.160000E+04
* #n5           0.000000E+00          0.200000E+04
*-----*
*
*NUMBER OF ELEMENTS CREATED
*
*      4
* ELM.NAME      TYPE.OF.ELEMENT      NOD.NAMES
* #e6           cbp2                 #n3      #n4
* #e7           cbp2                 #n4      #n5
* #e5           qdp2                 #n1      #n3
* #e8           qdp2                 #n5      #n2
*-----*
*
*NUMBER OF IMPERFECT ELEMENTS
*
*      0
*****

```

0	0.18076000E+02	0	0.638E-04	2
11	0.18080000E+02	0	0.130E-03	2
0	0.18084000E+02	0	0.293E-03	2

```

***** ( SUBDIVISION OF ELEMENT #e5 ) *****
*
*NUMBER OF NODES CREATED
*
*      1
* NOD.NAME      COORD'S (X,Y) RELATIVE TO END(1) OF SUBDIVIDED ELEMENT
* #n6           0.000000E+00          0.800000E+03
*-----*

```

```

*
*NUMBER OF ELEMENTS CREATED
*
*      2
* ELM.NAME      TYPE.OF.ELEMENT      NOD.NAMES
* #e10          cbp2                  #n6      #n3
* #e9           qdp2                  #n1      #n6
*-----*
*
*NUMBER OF IMPERFECT ELEMENTS
*
*      0
*****

***** ( SUBDIVISION OF ELEMENT #e8 )*****
*
*NUMBER OF NODES CREATED
*
*      1
* NOD.NAME      COORD'S (X,Y) RELATIVE TO END(1) OF SUBDIVIDED ELEMENT
* #n7           0.000000E+00          0.400000E+03
*-----*
*
*NUMBER OF ELEMENTS CREATED
*
*      2
* ELM.NAME      TYPE.OF.ELEMENT      NOD.NAMES
* #e11          cbp2                  #n5      #n7
* #e12          qdp2                  #n7      #n2
*-----*
*
*NUMBER OF IMPERFECT ELEMENTS
*
*      0
*****

12      0.18088000E+02    0      0.759E-05    3
0       0.18092000E+02    0      0.453E-03    2
13      0.18096000E+02    0      0.240E-05    3
0       0.18100000E+02    0      0.107E-04    3

***** ( SUBDIVISION OF ELEMENT 302 )*****
*
*NUMBER OF NODES CREATED
*
*      1
* NOD.NAME      COORD'S (X,Y) RELATIVE TO END(1) OF SUBDIVIDED ELEMENT
* #n8           0.000000E+00          0.400000E+03
*-----*
*
*NUMBER OF ELEMENTS CREATED
*
*      2
* ELM.NAME      TYPE.OF.ELEMENT      NOD.NAMES
* #e13          cbp2                  211      #n8
* #e14          qdp2                  #n8      221
*-----*
*
*NUMBER OF IMPERFECT ELEMENTS
*
*      0
*****

14      0.18104000E+02    0      0.322E-04    3

***** ( SUBDIVISION OF ELEMENT #e14 )*****
*
*NUMBER OF NODES CREATED
*

```

```

*          1
* NOD.NAME      COORD'S (X,Y) RELATIVE TO END(1) OF SUBDIVIDED ELEMENT
* #n9           0.000000E+00           0.320000E+04
*-----*
*
*NUMBER OF ELEMENTS CREATED
*          2
* ELM.NAME      TYPE.OF.ELEMENT          NOD.NAMES
* #e16          cbp2                    #n9      221
* #e15          qdp2                    #n8      #n9
*-----*
*
*NUMBER OF IMPERFECT ELEMENTS
*          0
*****
0          0.18108000E+02      0          0.335E-04      3

***** ( SUBDIVISION OF ELEMENT #e9 ) *****
*
*NUMBER OF NODES CREATED
*          1
* NOD.NAME      COORD'S (X,Y) RELATIVE TO END(1) OF SUBDIVIDED ELEMENT
* #n10          0.000000E+00           0.400000E+03
*-----*
*
*NUMBER OF ELEMENTS CREATED
*          2
* ELM.NAME      TYPE.OF.ELEMENT          NOD.NAMES
* #e18          cbp2                    #n10     #n6
* #e17          qdp2                    #n1      #n10
*-----*
*
*NUMBER OF IMPERFECT ELEMENTS
*          0
*****

***** ( SUBDIVISION OF ELEMENT #e12 ) *****
*
*NUMBER OF NODES CREATED
*          1
* NOD.NAME      COORD'S (X,Y) RELATIVE TO END(1) OF SUBDIVIDED ELEMENT
* #n11          0.000000E+00           0.400000E+03
*-----*
*
*NUMBER OF ELEMENTS CREATED
*          2
* ELM.NAME      TYPE.OF.ELEMENT          NOD.NAMES
* #e19          cbp2                    #n7      #n11
* #e20          qdp2                    #n11     #n2
*-----*
*
*NUMBER OF IMPERFECT ELEMENTS
*          0
*****
15         0.18112000E+02      0          0.480E-04      3
0          0.18116000E+02      0          0.267E-04      3
16         0.18120000E+02      0          0.205E-04      3
0          0.18124000E+02      0          0.583E-04      2

```

17	0.18128000E+02	0	0.485E-03	2
0	0.18132000E+02	0	0.323E-03	1
18	0.18136000E+02	0	0.595E-04	1
0	0.18140000E+02	0	0.148E-04	1
19	0.18144000E+02	0	0.385E-05	1
0	0.18148000E+02	0	0.551E-05	1
20	0.18152000E+02	0	0.290E-04	1
0	0.18156000E+02	0	0.206E-03	0
21	0.18160000E+02	0	0.119E-03	0
0	0.18164000E+02	0	0.837E-04	0
22	0.18168000E+02	0	0.171E-03	0
0	0.18172000E+02	0	0.458E-04	1
23	0.18176000E+02	0	0.268E-04	1
0	0.18180000E+02	0	0.398E-03	1
24	0.18184000E+02	0	0.270E-06	2
0	0.18188000E+02	0	0.204E-05	2
25	0.18192000E+02	0	0.165E-06	2
0	0.18196000E+02	0	0.200E-03	1
26	0.18200000E+02	0	0.560E-04	1
0	0.18240000E+02	0	0.569E-04	3
27	0.18280000E+02	0	0.263E-04	2
0	0.18320000E+02	0	0.184E-05	1
28	0.18360000E+02	0	0.186E-03	0
0	0.18400000E+02	0	0.269E-06	1
29	0.18440000E+02	0	0.133E-05	1
0	0.18480000E+02	0	0.314E-06	1
30	0.18520000E+02	0	0.474E-04	0
0	0.18560000E+02	0	0.126E-06	1
31	0.18600000E+02	0	0.352E-06	1
0	0.18640000E+02	0	0.551E-07	1
32	0.18680000E+02	0	0.353E-04	0
0	0.18720000E+02	0	0.389E-07	1
33	0.18760000E+02	0	0.106E-06	1
0	0.18800000E+02	0	0.457E-03	0
34	0.18840000E+02	0	0.379E-04	0
0	0.18880000E+02	0	0.493E-03	0
35	0.18920000E+02	0	0.438E-07	1
0	0.18960000E+02	0	0.266E-03	0
36	0.19000000E+02	0	0.312E-04	0
0	0.19040000E+02	0	0.340E-03	0
37	0.19080000E+02	0	0.487E-03	0
0	0.19120000E+02	0	0.153E-03	0
38	0.19160000E+02	0	0.215E-04	0
0	0.19200000E+02	0	0.281E-03	0
39	0.19240000E+02	0	0.314E-03	0
0	0.19280000E+02	0	0.669E-04	0
40	0.19320000E+02	0	0.366E-04	0
0	0.19360000E+02	0	0.213E-03	0
41	0.19400000E+02	0	0.202E-03	0
0	0.19440000E+02	0	0.386E-04	0
42	0.19480000E+02	0	0.513E-04	0
0	0.19520000E+02	0	0.166E-03	0
43	0.19560000E+02	0	0.121E-03	0
0	0.19600000E+02	0	0.169E-04	0
44	0.19640000E+02	0	0.403E-04	0
0	0.19680000E+02	0	0.101E-03	0
45	0.19720000E+02	0	0.577E-04	0
0	0.19760000E+02	0	0.432E-05	0
46	0.19800000E+02	0	0.375E-04	0
0	0.19840000E+02	0	0.756E-04	0
47	0.19880000E+02	0	0.458E-04	0

0	0.19920000E+02	0	0.248E-04	0
48	0.19960000E+02	0	0.497E-04	0
0	0.20000000E+02	0	0.621E-04	0
49	0.30000000E+02	0	0.216E-03	0
0	0.40000000E+02	0	0.227E-03	0
50	0.50000000E+02	0	0.184E-03	0
0	0.60000000E+02	0	0.191E-03	0
51	0.70000000E+02	0	0.197E-03	0
0	0.80000000E+02	0	0.189E-03	0
52	0.90000000E+02	0	0.187E-03	0
0	0.10000000E+03	0	0.187E-03	0
53	0.11000000E+03	0	0.180E-03	0
0	0.12000000E+03	0	0.183E-03	0
54	0.13000000E+03	0	0.183E-03	0
0	0.14000000E+03	0	0.181E-03	0
55	0.15000000E+03	0	0.178E-03	0
0	0.16000000E+03	0	0.175E-03	0
56	0.17000000E+03	0	0.173E-03	0
0	0.18000000E+03	0	0.171E-03	0
57	0.19000000E+03	0	0.170E-03	0
0	0.20000000E+03	0	0.169E-03	0
58	0.21000000E+03	0	0.166E-03	0
0	0.22000000E+03	0	0.164E-03	0
59	0.23000000E+03	0	0.162E-03	0
0	0.24000000E+03	0	0.161E-03	0
60	0.25000000E+03	0	0.160E-03	0
0	0.26000000E+03	0	0.158E-03	0
61	0.27000000E+03	0	0.156E-03	0
0	0.28000000E+03	0	0.154E-03	0
62	0.29000000E+03	0	0.152E-03	0
0	0.30000000E+03	0	0.151E-03	0
63	0.31000000E+03	0	0.149E-03	0
0	0.32000000E+03	0	0.148E-03	0
64	0.33000000E+03	0	0.146E-03	0
0	0.34000000E+03	0	0.144E-03	0

***** (SUBDIVISION OF ELEMENT 104)*****

```

*
*NUMBER OF NODES CREATED
*
*          9
* NOD.NAME      COORD'S (X,Y) RELATIVE TO END(1) OF SUBDIVIDED ELEMENT
* #n12          0.600000E+03      0.000000E+00
* #n13          0.120000E+04      0.000000E+00
* #n14          0.180000E+04      0.000000E+00
* #n15          0.240000E+04      0.000000E+00
* #n16          0.300000E+04      0.000000E+00
* #n17          0.360000E+04      0.000000E+00
* #n18          0.420000E+04      0.000000E+00
* #n19          0.480000E+04      0.000000E+00
* #n20          0.540000E+04      0.000000E+00
*-----*
*
*NUMBER OF ELEMENTS CREATED
*
*          10
* ELM.NAME      TYPE.OF.ELEMENT      NOD.NAMES
* #e21          cbp2          121      #n12
* #e22          cbp2          #n12      #n13
* #e23          cbp2          #n13      #n14
* #e24          cbp2          #n14      #n15
* #e25          cbp2          #n15      #n16
* #e26          cbp2          #n16      #n17

```

```

* #e27          cbp2          #n17      #n18          *
* #e28          cbp2          #n18      #n19          *
* #e29          cbp2          #n19      #n20          *
* #e30          cbp2          #n20      221          *

```

```

*-----*
*
*NUMBER OF IMPERFECT ELEMENTS
*          0
*****

```

0	0.34100000E+03	1	0.265E-06	1
0	0.34200000E+03	1	0.310E-05	0
0	0.34300000E+03	1	0.311E-05	0
0	0.34400000E+03	1	0.308E-05	0
0	0.34500000E+03	1	0.295E-05	0
0	0.34600000E+03	1	0.290E-05	0
0	0.34700000E+03	1	0.294E-05	0
0	0.34800000E+03	1	0.302E-05	0
0	0.34900000E+03	1	0.303E-05	0
65	0.35000000E+03	1	0.299E-05	0
0	0.36000000E+03	0	0.153E-06	1
66	0.37000000E+03	0	0.289E-03	0
0	0.38000000E+03	0	0.284E-03	0
67	0.39000000E+03	0	0.281E-03	0
0	0.40000000E+03	0	0.311E-06	1

```

***** ( SUBDIVISION OF ELEMENT #e17 ) *****

```

```

*
*NUMBER OF NODES CREATED
*          0

```

```

*-----*

```

```

*
*NUMBER OF ELEMENTS CREATED
*          1

```

```

* ELM.NAME      TYPE.OF.ELEMENT      NOD.NAMES
* #e31          cbp2          #n1      #n10

```

```

*-----*

```

```

*
*NUMBER OF IMPERFECT ELEMENTS

```

```

*          0

```

```

*****

```

```

***** ( SUBDIVISION OF ELEMENT #e20 ) *****

```

```

*
*NUMBER OF NODES CREATED

```

```

*          0

```

```

*-----*

```

```

*
*NUMBER OF ELEMENTS CREATED

```

```

*          1

```

```

* ELM.NAME      TYPE.OF.ELEMENT      NOD.NAMES
* #e32          cbp2          #n11      #n2

```

```

*-----*

```

```

*
*NUMBER OF IMPERFECT ELEMENTS

```

```

*          0

```

```

*****

```

0	0.40100000E+03	1	0.149E-07	2
0	0.40200000E+03	1	0.317E-03	0

0	0.40300000E+03	1	0.268E-05	0
0	0.40400000E+03	1	0.269E-05	0
0	0.40500000E+03	1	0.276E-05	0
0	0.40600000E+03	1	0.286E-05	0
0	0.40700000E+03	1	0.286E-05	0
0	0.40800000E+03	1	0.276E-05	0
0	0.40900000E+03	1	0.269E-05	0
68	0.41000000E+03	1	0.268E-05	0
0	0.42000000E+03	0	0.731E-08	1

***** (SUBDIVISION OF ELEMENT #e15)*****

* * * * *

*NUMBER OF NODES CREATED * *

* 1 * *

* NOD.NAME COORD'S (X,Y) RELATIVE TO END(1) OF SUBDIVIDED ELEMENT * *

* #n21 0.000000E+00 0.280000E+04 * *

----- *

* * * * *

*NUMBER OF ELEMENTS CREATED * *

* 2 * *

* ELM.NAME TYPE.OF.ELEMENT NOD.NAMES * *

* #e34 cbp2 #n21 #n9 * *

* #e33 qdp2 #n8 #n21 * *

----- *

* * * * *

*NUMBER OF IMPERFECT ELEMENTS * *

* 0 * *

0	0.42100000E+03	1	0.378E-07	3
0	0.42200000E+03	1	0.342E-04	1
0	0.42300000E+03	1	0.659E-07	1
0	0.42400000E+03	1	0.533E-08	1
0	0.42500000E+03	1	0.528E-08	1
0	0.42600000E+03	1	0.884E-09	1
0	0.42700000E+03	1	0.395E-08	1
0	0.42800000E+03	1	0.672E-08	1
0	0.42900000E+03	1	0.113E-08	1
69	0.43000000E+03	1	0.609E-07	1

***** (SUBDIVISION OF ELEMENT #e33)*****

* * * * *

*NUMBER OF NODES CREATED * *

* 1 * *

* NOD.NAME COORD'S (X,Y) RELATIVE TO END(1) OF SUBDIVIDED ELEMENT * *

* #n22 0.000000E+00 0.400000E+03 * *

----- *

* * * * *

*NUMBER OF ELEMENTS CREATED * *

* 2 * *

* ELM.NAME TYPE.OF.ELEMENT NOD.NAMES * *

* #e35 cbp2 #n8 #n22 * *

* #e36 qdp2 #n22 #n21 * *

----- *

* * * * *

*NUMBER OF IMPERFECT ELEMENTS * *

* 0 * *

0	0.43100000E+03	1	0.130E-03	3
0	0.43200000E+03	1	0.383E-08	1

0	0.43300000E+03	1	0.133E-08	1
0	0.43400000E+03	1	0.281E-08	1
0	0.43500000E+03	1	0.191E-08	1
0	0.43600000E+03	1	0.203E-08	1
0	0.43700000E+03	1	0.185E-08	1
0	0.43800000E+03	1	0.283E-08	1
0	0.43900000E+03	1	0.467E-03	0
0	0.44000000E+03	1	0.152E-05	1

***** (SUBDIVISION OF ELEMENT #e36)*****

* * * * *

*NUMBER OF NODES CREATED * *

* 1 * *

* NOD.NAME COORD'S (X,Y) RELATIVE TO END(1) OF SUBDIVIDED ELEMENT * *

* #n23 0.000000E+00 0.200000E+04 * *

----- *

* * * * *

*NUMBER OF ELEMENTS CREATED * *

* 2 * *

* ELM.NAME TYPE.OF.ELEMENT NOD.NAMES * *

* #e38 cbp2 #n23 #n21 * *

* #e37 qdp2 #n22 #n23 * *

----- *

* * * * *

*NUMBER OF IMPERFECT ELEMENTS * *

* 0 * *

0	0.44100000E+03	1	0.397E-04	2
0	0.44200000E+03	1	0.335E-03	0
0	0.44300000E+03	1	0.354E-03	0
0	0.44400000E+03	1	0.334E-03	0
0	0.44500000E+03	1	0.215E-05	2
0	0.44600000E+03	1	0.458E-08	1
0	0.44700000E+03	1	0.387E-03	0
0	0.44800000E+03	1	0.520E-08	1
0	0.44900000E+03	1	0.233E-05	1
70	0.45000000E+03	1	0.458E-03	0

***** (SUBDIVISION OF ELEMENT #e37)*****

* * * * *

*NUMBER OF NODES CREATED * *

* 2 * *

* NOD.NAME COORD'S (X,Y) RELATIVE TO END(1) OF SUBDIVIDED ELEMENT * *

* #n24 0.000000E+00 0.400000E+03 * *

* #n25 0.000000E+00 0.160000E+04 * *

----- *

* * * * *

*NUMBER OF ELEMENTS CREATED * *

* 3 * *

* ELM.NAME TYPE.OF.ELEMENT NOD.NAMES * *

* #e39 cbp2 #n22 #n24 * *

* #e41 cbp2 #n25 #n23 * *

* #e40 qdp2 #n24 #n25 * *

----- *

* * * * *

*NUMBER OF IMPERFECT ELEMENTS * *

* 0 * *

0	0.45010000E+03	2	0.215E-03	1
---	----------------	---	-----------	---

0	0.45020000E+03	2	0.187E-04	0
0	0.45030000E+03	2	0.925E-07	0
0	0.45040000E+03	2	0.434E-05	0
0	0.45050000E+03	2	0.919E-07	0
0	0.45060000E+03	2	0.911E-07	0
0	0.45070000E+03	2	0.420E-04	0
0	0.45080000E+03	2	0.926E-07	0
0	0.45090000E+03	2	0.136E-04	0
0	0.45100000E+03	2	0.929E-07	0
0	0.45200000E+03	1	0.846E-08	1
0	0.45300000E+03	1	0.118E-04	1
0	0.45400000E+03	1	0.431E-03	1
0	0.45500000E+03	1	0.371E-04	1
0	0.45600000E+03	1	0.477E-04	1
0	0.45700000E+03	1	0.692E-04	1
0	0.45800000E+03	1	0.181E-04	2
0	0.45900000E+03	1	0.133E-03	2
0	0.46000000E+03	1	0.440E-03	1
0	0.46010000E+03	2	0.359E-04	3
0	0.46020000E+03	2	0.134E-04	0
0	0.46030000E+03	2	0.779E-05	0
0	0.46040000E+03	2	0.321E-04	0
0	0.46050000E+03	2	0.131E-04	0
0	0.46060000E+03	2	0.603E-04	0
0	0.46070000E+03	2	0.226E-04	0
0	0.46080000E+03	2	0.163E-04	0
0	0.46090000E+03	2	0.240E-04	0
0	0.46100000E+03	2	0.591E-04	0

```

***** ( SUBDIVISION OF ELEMENT #e40 )*****
*
*NUMBER OF NODES CREATED
* 1
* NOD.NAME      COORD'S (X,Y) RELATIVE TO END(1) OF SUBDIVIDED ELEMENT
* #n26          0.000000E+00          0.400000E+03
*-----*
*
*NUMBER OF ELEMENTS CREATED
* 2
* ELM.NAME      TYPE.OF.ELEMENT      NOD.NAMES
* #e42          cbp2                  #n24      #n26
* #e43          qdp2                  #n26      #n25
*-----*
*
*NUMBER OF IMPERFECT ELEMENTS
* 0
*****

```

0	0.46110000E+03	2	0.357E-05	2
0	0.46120000E+03	2	0.197E-03	0
0	0.46130000E+03	2	0.300E-03	0
0	0.46140000E+03	2	0.796E-04	1
0	0.46150000E+03	2	0.675E-04	0
0	0.46160000E+03	2	0.607E-04	0
0	0.46170000E+03	2	0.630E-04	0
0	0.46180000E+03	2	0.707E-04	0
0	0.46190000E+03	2	0.524E-04	0
0	0.46200000E+03	2	0.911E-04	0
0	0.46300000E+03	1	0.232E-04	2
0	0.46400000E+03	1	0.203E-05	1

```

***** ( SUBDIVISION OF ELEMENT #e43 ) *****
*
*NUMBER OF NODES CREATED
*          1
* NOD.NAME      COORD'S (X,Y) RELATIVE TO END(1) OF SUBDIVIDED ELEMENT
* #n27          0.000000E+00          0.400000E+03
*-----*
*
*NUMBER OF ELEMENTS CREATED
*          2
* ELM.NAME      TYPE.OF.ELEMENT      NOD.NAMES
* #e45          cbp2                  #n27      #n25
* #e44          qdp2                  #n26      #n27
*-----*
*
*NUMBER OF IMPERFECT ELEMENTS
*          0
*****
0          0.46410000E+03      2          0.417E-05          2
0          0.46420000E+03      2          0.278E-03          0
0          0.46430000E+03      2          0.177E-03          0
0          0.46440000E+03      2          0.210E-03          0
0          0.46450000E+03      2          0.151E-03          0
0          0.46460000E+03      2          0.123E-03          0
0          0.46470000E+03      2          0.111E-03          0
0          0.46480000E+03      2          0.123E-03          0
0          0.46490000E+03      2          0.119E-03          0
0          0.46500000E+03      2          0.126E-03          0
0          0.46600000E+03      1          0.846E-04          2

***** ( SUBDIVISION OF ELEMENT #e44 ) *****
*
*NUMBER OF NODES CREATED
*          0
*-----*
*
*NUMBER OF ELEMENTS CREATED
*          1
* ELM.NAME      TYPE.OF.ELEMENT      NOD.NAMES
* #e46          cbp2                  #n26      #n27
*-----*
*
*NUMBER OF IMPERFECT ELEMENTS
*          0
*****
0          0.46601000E+03      3          0.131E-03          1
0          0.46602000E+03      3          0.357E-04          0
0          0.46603000E+03      3          0.122E-04          0
0          0.46604000E+03      3          0.252E-05          0
0          0.46605000E+03      3          0.347E-05          0
0          0.46606000E+03      3          0.303E-07          0
0          0.46607000E+03      3          0.305E-07          0
0          0.46608000E+03      3          0.160E-05          0
0          0.46609000E+03      3          0.115E-06          0
0          0.46610000E+03      3          0.443E-05          0
0          0.46620000E+03      2          0.458E-03          0
0          0.46630000E+03      2          0.158E-03          0
0          0.46640000E+03      2          0.109E-03          0
0          0.46650000E+03      2          0.410E-04          0

```

0	0.46660000E+03	2	0.379E-03	0
0	0.46670000E+03	2	0.180E-04	0
0	0.46680000E+03	2	0.307E-04	0
0	0.46690000E+03	2	0.365E-04	0
0	0.46700000E+03	2	0.321E-03	0
0	0.46800000E+03	1	0.774E-04	4
0	0.46900000E+03	1	0.433E-03	2
71	0.47000000E+03	1	0.504E-04	3
0	0.48000000E+03	0	0.473E-04	5
72	0.49000000E+03	0	0.105E-03	2
0	0.50000000E+03	0	0.767E-05	2
73	0.51000000E+03	0	0.289E-05	2
0	0.52000000E+03	0	0.720E-06	2
74	0.53000000E+03	0	0.210E-06	2
0	0.54000000E+03	0	0.773E-07	2
75	0.55000000E+03	0	0.380E-03	1
0	0.56000000E+03	0	0.103E-06	2
76	0.57000000E+03	0	0.742E-04	2
0	0.58000000E+03	0	0.180E-03	1
77	0.59000000E+03	0	0.262E-03	1
0	0.60000000E+03	0	0.963E-07	2
78	0.61000000E+03	0	0.798E-06	2
0	0.62000000E+03	0	0.483E-07	2
79	0.63000000E+03	0	0.241E-07	2
0	0.64000000E+03	0	0.165E-04	3
0	0.64010000E+03	1	0.574E-04	1
0	0.64020000E+03	1	0.274E-04	0
0	0.64030000E+03	1	0.367E-04	0
0	0.64040000E+03	1	0.140E-05	1
0	0.64050000E+03	1	0.246E-03	0
0	0.64060000E+03	1	0.399E-03	1
0	0.64070000E+03	1	0.242E-04	1
0	0.64080000E+03	1	0.150E-05	1
0	0.64090000E+03	1	0.275E-05	1
80	0.64100000E+03	1	0.502E-04	1
0	0.64110000E+03	1	0.293E-03	1
0	0.64120000E+03	1	0.406E-04	1
0	0.64130000E+03	1	0.410E-03	1
0	0.64140000E+03	1	0.265E-03	2
0	0.64150000E+03	1	0.437E-05	3
0	0.64160000E+03	1	0.217E-05	4
0	0.64161000E+03	2	0.495E-03	3
0	0.64162000E+03	2	0.500E-04	2
0	0.64163000E+03	2	0.807E-04	2
0	0.64164000E+03	2	0.416E-04	2
0	0.64165000E+03	2	0.555E-04	2
0	0.64166000E+03	2	0.386E-03	1
0	0.64167000E+03	2	0.288E-04	2
0	0.64168000E+03	2	0.111E-07	3
0	0.64169000E+03	2	0.387E-04	1
0	0.64170000E+03	2	0.147E-03	1
0	0.64171000E+03	2	0.355E-04	3

```

***** ( SUBDIVISION OF ELEMENT 304 ) *****
*
*NUMBER OF NODES CREATED
* 1
* NOD.NAME COORD'S (X,Y) RELATIVE TO END(1) OF SUBDIVIDED ELEMENT
* #n28 0.000000E+00 0.400000E+03
*-----*
*

```

```

*NUMBER OF ELEMENTS CREATED
*          2
* ELM.NAME   TYPE.OF.ELEMENT      NOD.NAMES
* #e47       cbp2                 301      #n28
* #e48       qdp2                 #n28     311
*-----*
*
*NUMBER OF IMPERFECT ELEMENTS
*          0
*****

0          0.64172000E+03    2          0.317E-03          3

***** ( SUBDIVISION OF ELEMENT #e48 ) *****
*
*NUMBER OF NODES CREATED
*          1
* NOD.NAME   COORD'S (X,Y) RELATIVE TO END(1) OF SUBDIVIDED ELEMENT
* #n29       0.000000E+00          0.320000E+04
*-----*
*
*NUMBER OF ELEMENTS CREATED
*          2
* ELM.NAME   TYPE.OF.ELEMENT      NOD.NAMES
* #e50       cbp2                 #n29     311
* #e49       qdp2                 #n28     #n29
*-----*
*
*NUMBER OF IMPERFECT ELEMENTS
*          0
*****

0          0.64173000E+03    2          0.392E-07          4

***** ( SUBDIVISION OF ELEMENT #e49 ) *****
*
*NUMBER OF NODES CREATED
*          1
* NOD.NAME   COORD'S (X,Y) RELATIVE TO END(1) OF SUBDIVIDED ELEMENT
* #n30       0.000000E+00          0.400000E+03
*-----*
*
*NUMBER OF ELEMENTS CREATED
*          2
* ELM.NAME   TYPE.OF.ELEMENT      NOD.NAMES
* #e51       cbp2                 #n28     #n30
* #e52       qdp2                 #n30     #n29
*-----*
*
*NUMBER OF IMPERFECT ELEMENTS
*          0
*****

***** ( SUBDIVISION OF ELEMENT 305 ) *****
*
*NUMBER OF NODES CREATED
*          1
* NOD.NAME   COORD'S (X,Y) RELATIVE TO END(1) OF SUBDIVIDED ELEMENT
* #n31       0.000000E+00          0.360000E+04
*-----*

```

```

*
*NUMBER OF ELEMENTS CREATED
*
*          2
* ELM.NAME   TYPE.OF.ELEMENT   NOD.NAMES
* #e54       cbp2              #n31      321
* #e53       qdp2              311         #n31
*-----*
*
*NUMBER OF IMPERFECT ELEMENTS
*
*          0
*****

      0          0.64174000E+03      2          0.101E-06          4

***** ( SUBDIVISION OF ELEMENT #e53 ) *****
*
*NUMBER OF NODES CREATED
*
*          1
* NOD.NAME   COORD'S (X,Y) RELATIVE TO END(1) OF SUBDIVIDED ELEMENT
* #n32       0.000000E+00          0.320000E+04
*-----*
*
*NUMBER OF ELEMENTS CREATED
*
*          2
* ELM.NAME   TYPE.OF.ELEMENT   NOD.NAMES
* #e56       cbp2              #n32      #n31
* #e55       qdp2              311         #n32
*-----*
*
*NUMBER OF IMPERFECT ELEMENTS
*
*          0
*****

      0          0.64175000E+03      2          0.172E-06          4

***** ( SUBDIVISION OF ELEMENT #e52 ) *****
*
*NUMBER OF NODES CREATED
*
*          1
* NOD.NAME   COORD'S (X,Y) RELATIVE TO END(1) OF SUBDIVIDED ELEMENT
* #n33       0.000000E+00          0.240000E+04
*-----*
*
*NUMBER OF ELEMENTS CREATED
*
*          2
* ELM.NAME   TYPE.OF.ELEMENT   NOD.NAMES
* #e58       cbp2              #n33      #n29
* #e57       qdp2              #n30      #n33
*-----*
*
*NUMBER OF IMPERFECT ELEMENTS
*
*          0
*****

      0          0.64176000E+03      2          0.243E-06          4
      0          0.64177000E+03      2          0.436E-03          1
      0          0.64178000E+03      2          0.723E-05          2

***** ( SUBDIVISION OF ELEMENT #e55 ) *****
*
*NUMBER OF NODES CREATED

```

```

*          1
* NOD.NAME      COORD'S (X,Y) RELATIVE TO END(1) OF SUBDIVIDED ELEMENT *
* #n34          0.000000E+00          0.280000E+04
*-----*
*
*NUMBER OF ELEMENTS CREATED
*          2
* ELM.NAME      TYPE.OF.ELEMENT      NOD.NAMES
* #e60          cbp2                  #n34      #n32
* #e59          qdp2                  311      #n34
*-----*
*
*NUMBER OF IMPERFECT ELEMENTS
*          0
*****
0          0.64179000E+03      2          0.127E-03      4
0          0.64180000E+03      2          0.319E-04      2
0          0.64181000E+03      2          0.396E-03      4

***** ( SUBDIVISION OF ELEMENT #e57 ) *****
*
*NUMBER OF NODES CREATED
*          2
* NOD.NAME      COORD'S (X,Y) RELATIVE TO END(1) OF SUBDIVIDED ELEMENT *
* #n35          0.000000E+00          0.400000E+03
* #n36          0.000000E+00          0.200000E+04
*-----*
*
*NUMBER OF ELEMENTS CREATED
*          3
* ELM.NAME      TYPE.OF.ELEMENT      NOD.NAMES
* #e61          cbp2                  #n30      #n35
* #e63          cbp2                  #n36      #n33
* #e62          qdp2                  #n35      #n36
*-----*
*
*NUMBER OF IMPERFECT ELEMENTS
*          0
*****
0          0.64182000E+03      2          0.122E-08      6
81         0.64182000E+03      4          0.191E+00      10

```

9.7 Apexes

-
-
- (a) Indicates the kind of analysis required.
 - (b) Introduces the characteristics of the materials: the name, the material model, and the properties, which are different for each material model ([Chapter 3](#)).
 - (c) Introduces the [type of section](#), the name, material and the dimensions.
 - (d) Defines the groups. There you define the [element type](#), the [group](#) name and the name give to the section.
 - (e) Defines the coordinates of the [structural nodes](#).
 - (f) Defines the global coordinates of the structural nodes ([non.structural.nodes](#)).
 - (g) Defined the nodal restraints. The f-command indicates the name of the first nodes which has [restraints](#), and the r-command is referred to the increment of this and how many times it has to increment the nod.name.
 - (h) Defines the [connectivity of elements](#) in a mesh configuration. First is indicated the group name. At the f-command is the name of the element and the extreme nodes of it and at the r-command is defined the increment of the nod.name, the extreme nodes and when it has to stop.
 - (i) Indicates the kind of [load](#) and the direction of each one.
 - (j) This module, [phases](#), is used to trace the load deflection curve for the proportional loading.
 - (k) This module specifies the [iterative strategy](#) applied during a load or time step.
 - (l) Defines the tolerance at the iterative calculating process, and the reference value in calculating the [convergence](#).
 - (m) Specifies the frequency of numerical [output](#).
 - (n) This module specifies levels within elements of specific types ([*](#)).
 - (o) This module specifies the conditions which govern the termination of the automatic control phrase under a proportional static loading regime ([**](#)).
 - (p) This modules defines subdivision [patterns](#) utilised in automatic mesh refinement.
 - (q) This module specifies piecewise [linear load curves](#) for dynamic or time history loading.
 - (r) This module specifies the time scheme for dynamic analysis and its parameters ([***](#)).

(s) This module defines of intervals at which structural equilibrium is established [****](#) .
