

Sponsors and Collaborators



C. FANG, B.A. IZZUDDIN, A.Y. ELGHAZOULI and D.A. NETHERCOT

Department of Civil and Environmental Engineering, Imperial College London

INTRODUCTION

A localised fire which develops in an unprotected steel composite car park (figure 1) leads to the heating of nearby structural elements, which may result locally in a significant reduction of the carrying capacity of one or two columns and consequently to a loss of global stability of the car park. Although some codes already incorporate guidance for the assessment and design of structural robustness, they are not immediately applicable to fire conditions, and a considerable gap therefore exists between fire resistance and structural robustness research. To address this, two alternative approaches are proposed within a design-oriented framework, namely, a temperature-dependent approach (TDA) and a temperature-independent approach (TIA).

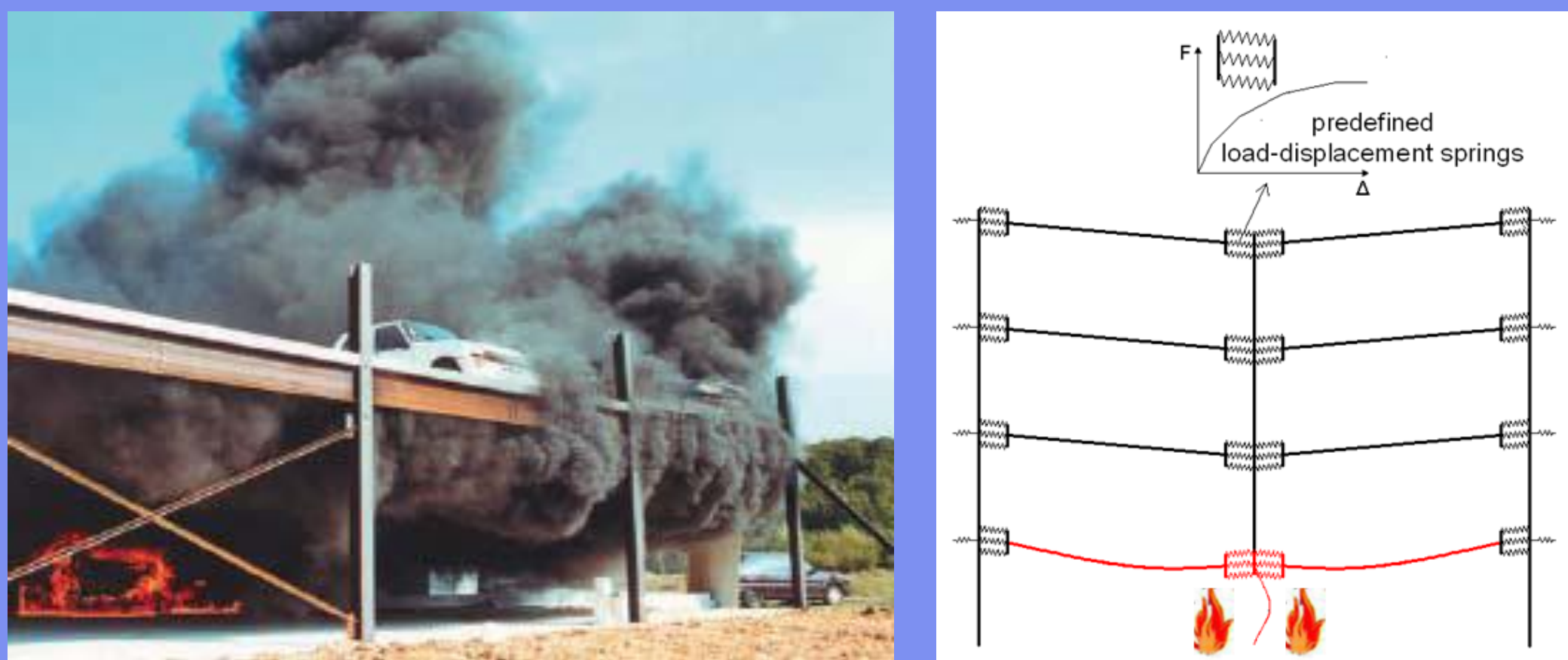

Figure 1: Car park under localised fire

DEVELOPMENT OF MULTI-LEVEL SYSTEM MODELS

Multi-level system models are developed for variable design requirements, as shown in figure 2. At level A, consideration is given to the affected floor systems with appropriate boundary conditions representing the surrounding ambient structure. The assessment model can be simplified to level B, where a reduced model consisting of a fire affected floor-column system and an upper ambient floor system can be considered. At this level, the two structural systems, fire and ambient, are investigated separately. At level C, planar effects such as membrane action within the floor slab are ignored, and grillage models consisting of composite beams are considered, offering a simplified treatment of both the ambient and fire affected substructures.

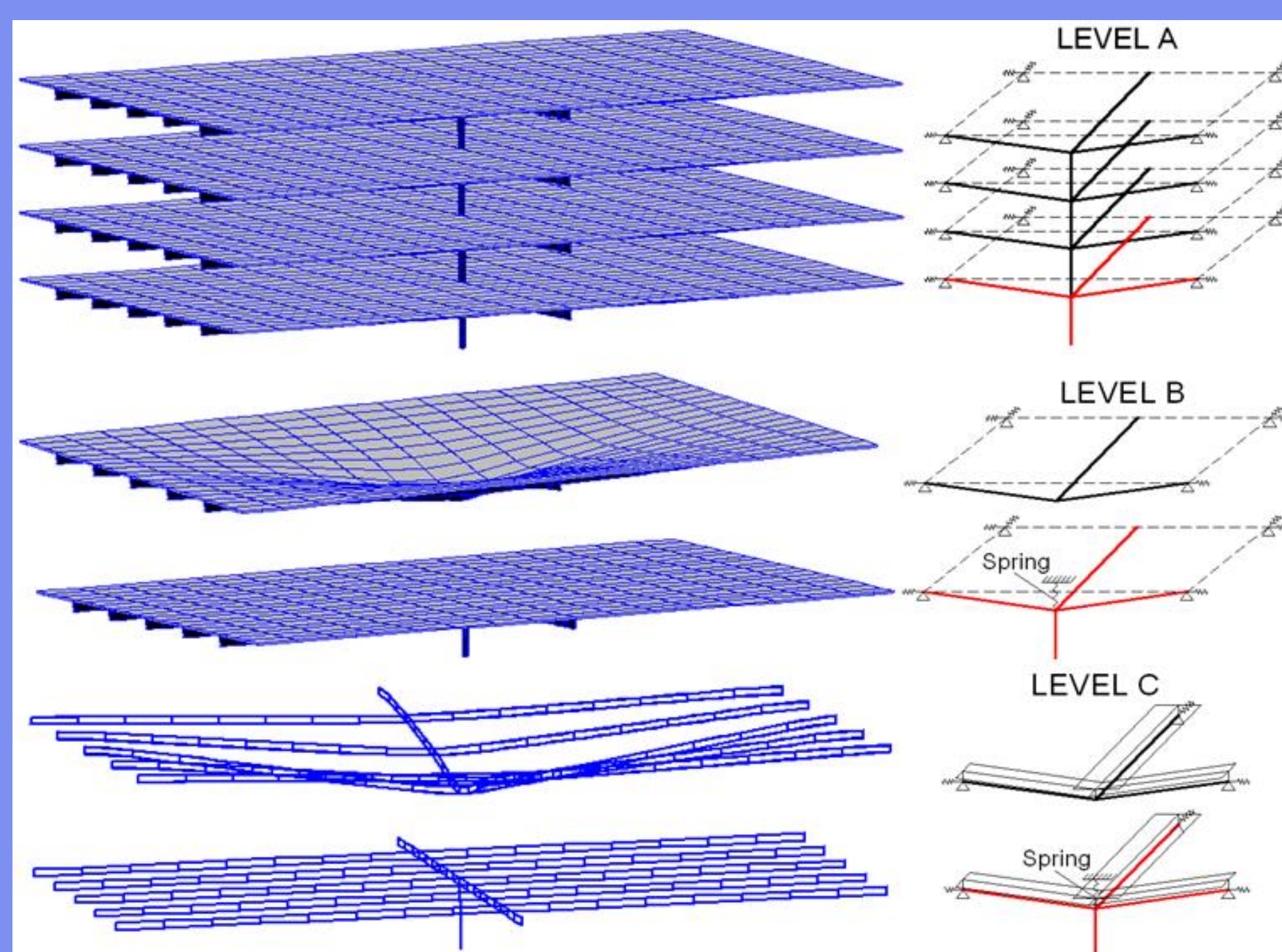

Figure 2: Multi-level system model

JOINT DUCTILITY SUPPLY

System failure is considered to occur when the deformation of either the fire affected floor or the upper ambient floors exceeds their respective ductility capacity. In this respect, the failure of any floor system is attributed to the ductility failure of the first

joint on that floor, thus failure criteria are defined in terms of whether the ductility limits of the joints are exceeded. The component method is employed for modelling joints, as shown in figure 3.

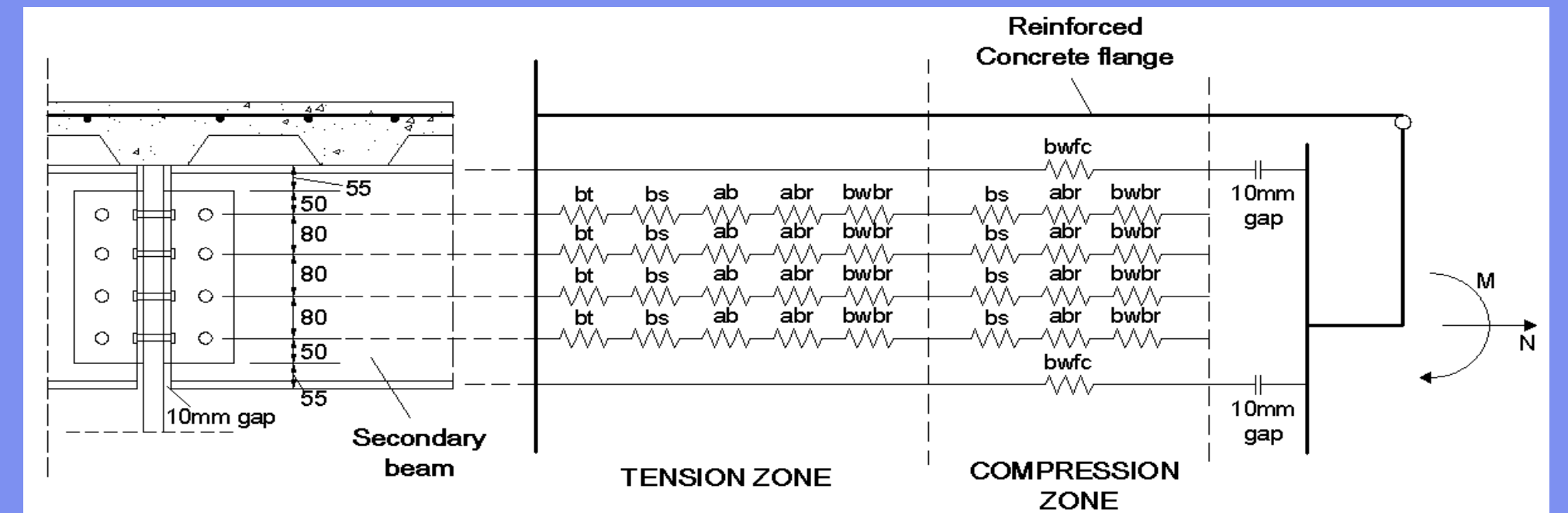

Figure 3: Component modelling of composite joint

APPLICATION OF 'TDA' AND 'TIA'

For TDA models, the localised fire is assumed to occur near the considered internal column, such that both the targeted column and the above local ceiling area are affected. Figure 4 shows the deflected shape of the TDA model (Level C model) after buckling of the fire affected column, as well as the modelling details of the sagging joint assemblies.

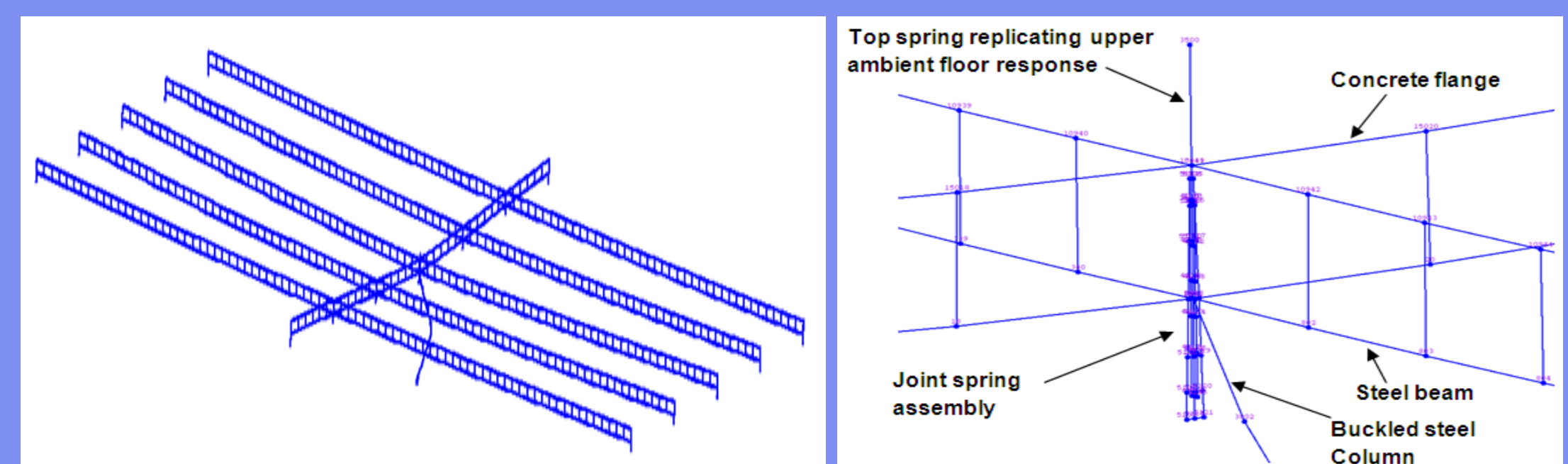

Figure 4: Illustration of deflected TDA model (Level C)

For TIA models, as illustrated in figure 5 (Level B model), the fire affected column is assumed to lose all its resistance, and the steel connections immediately above the fire are also completely removed. It is shown that the TIA can be relatively accurate for severe fires and realistic when the maximum temperature is not known. In addition, TIA can also be used as the first stage of assessment.

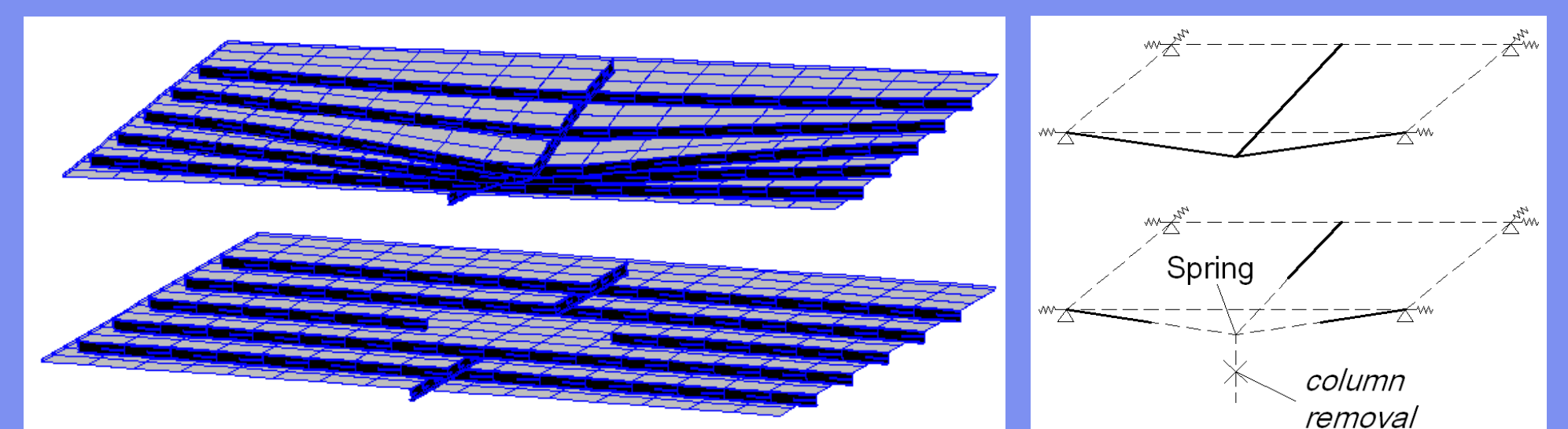

Figure 5: Illustration of TIA model (Level B)

CONCLUSIONS

The TDA requires the definition of elevated temperature scenarios and can thus predict the fire response of structures more accurately. The simplified TIA can provide a quick assessment of structural robustness under localised fire, which does not require the specification of temperatures. This approach is typically conservative, but can be relatively accurate for severe fires and realistic when the maximum temperature is not known. It can also be used as the first stage of assessment, which could be supplemented with a subsequent stage considering the column fire resistance when the structure is deemed to be prone to progressive collapse under a complete column loss.

REFERENCES

IZZUDDIN B.A., VLASSIS A.G., ELGHAZOULI A.Y. AND NETHERCOT D.A. Progressive Collapse of Multi-Storey Buildings due to Sudden Column Loss – Part I: Simplified Assessment Framework. *Engineering Structures*, 2008, 30, No.5, pp. 1308-1318.